

Table of Contents

Thermal Expansion Valves	1-39
TXV Extended Capacity Tables	40-60
EX Valves & Controls	61-74
Solenoid Valves & Coils	75-93
Solenoid Capacity Tables	94-96
Industrial Solenoid Valves	97-112
Shut Off Valves	113-114
System Protectors	115-149
System Protectors Capacity Tables	150-156
Oil Controls	157-166
Temperature Pressure Controls	167-178

Thermal Expansion Valves	1
A-Series	2
AFA(E) Series	5
NXT Series R-410A	8
TXV Connect Kit	10
HF/HFK Series	11
TRAE+ Series	22
TRAE Series	23
T Series—Take Apart	25
TLE Series	29
TFE R-22 Series	31
TFE R-410A Series	32
TI Series	33
ZZ Series	34
LCL Take-Apart	36
ACP(E) Series	38
Thermal Expansion Valves Extended Capacity Tables	40
EX Valves & Controls	61
EX2 – Pulse Modulated Electric	61
EX2 Extended Capacity Tables	63
EX4 - EX8 Electrical Control Valve	66
EXD-U00 Universal Driver Module	68
EC3 - X32 Superheat Controller	69
EC3 - X33 Superheat Controller	70
EC3-D72 Digital Suprheat Controller	71
ECD - 002 Display Unit	72
Pressure Transmitters	73
XEV Kit	74
Solenoid Valves & Coils	75
100RB	76
200RB	78
200RD	81
240RA	83
500RB	85
540RA	87
Coils for Solenoids	89
Solenoid Multi-Purpose Tool	93
Solenoid Capacity Tables	94
Industrial Solenoid Valves	97
202CB	98
203CA	100
204CD	102
210CA/211CA	104
214CB	106
222CB	108

314UB	110
Cross Reference	112
Shut Off Valves	113
ACK	113
BV	114
System Protectors	115
EK	118
ADK	121
BFK	123
BOK-HH	125
ALF	127
Spun Copper	128
STAS	130
ADKS	132
Filter Drier Cores and Filters	134
BTAS	135
ASD	137
SFD	138
CSFD	139
ASK-HH	140
ASF	141
Builder Series	142
APD	143
HMI	144
AMI	146
A-IHL	148
A-AS	149
System Protectors Capacity Tables	150
Oil Controls	157
DCFM Charge Calculations	157
High Efficiency Centrifugal Oil Separator	159
A-W & A-F	160
AOR	161
AOF	162
AOFD 553	163
OMB	164
W-OLC	165
Universal Test Kit	166
Temperature Pressure Control	167
TS1	168
PS1	170
PS2	172
FD113-ZUK	173
PSC	174
FSX	177
FF444	178

Alpha Numeric by Product

Product	Page
100RB	76
200RB	78
200RD	81
202CB	98
203CA	100
204CD	102
210CA/211CA	104
214CB	106
222CB	108
240RA	83
314UB	110
500RB	85
540RA	87
A-Series	2
A-AS	149
ACK	113
ACP(E)	38
ADK	121
ADKS	132
A-F	160
AFA(E)	5
A-IHL	148
ALF	127
AMI	146
AOF	162
AOFD 553	163
AOR	161
APD	143
ASD	137
ASF	141
ASK-HH	140
A-W & A-F	160
BFK	123
BOK-HH	125
BTAS	135
Builder Series	142
BV	114
COILS	89
Cores & Filters	134

Product	Page
CSFD	139
EC3-D72 Digital Superheat Controller	71
EC3-X32	69
EC3-X33	70
ECD-002	72
EK	118
EX2	61
EX4-EX8	66
EXD-U00	68
FD113-ZUK	173
FF444	178
FSX	177
HF	11
HFK	11
HMI	144
LCL Take-Apart	36
NXT Series R-410A	8
OMB	164
PS1	170
PS2	172
PSC	174
Pressure Transmitters	73
SFD	138
Solenoid Multi-Purpose Tool	93
Spun Copper	128
STAS	130
T-Series-Take Apart	25
TFE R-22	31
TFE R-410A	32
TI	33
TLE	29
TRAE	23
TRAE+	22
TS1	168
TXV Connect Kits	10
Universal Acid Test Kit	166
W-OLC	165
XEV Kit	74
ZZ	34

Quick Select Guide

Application	Nominal Capacity		Valve Family	Adjustable Superheat	Internal Check	Style			Connections		Configuration		Port	
	R-22	R-410A				Hermetic	Replaceable Power Element	Field Serviceable	SAE	ODF	Angle	Straight	Conventional	Balanced
Air Conditioning and Refrigeration	1/4 to 5	1 ¼ to 5	AA	X		X				X		X	X	
	1/4 to 5	1 ¼ to 5	AN			X				X	X	X	X	
	1/4 to 5	1 ¼ to 5	AAC	X	X	X				X		X	X	
	1/4 to 5	1 ¼ to 5	ANC		X	X				X	X	X	X	
	1/4 to 5		AFA	X		X			X		X		X	
		½ to 7 ½	C	X	X	X			X	X	X	X		X
	1/4 to 5 1/2		HFK	X			X	X	X	X	X	X		X
	1/4 to 5 1/2		HF	X			X		X	X	X	X		X
	8 to 20		HF EXT	X			X		X	X	X	X		X
	1/3 to 5		TI	X				X	X		X		X	
	8 to 20	12 to 20	TF	X			X			X		X		X
	1/2 to 12		TL					X	X	X	X	X	X	
	1/2 to 12		TCL	X				X	X	X	X	X	X	
	11 and 14		TJL	X				X		X	X	X	X	
	14 and 18		TJR	X				X		X	X	X	X	X
	22 to 45		TER	X				X		X	X	X		X
	55		TIR	X				X		X	X	X		X
70 and 85		THR	X				X		X	X	X		X	
100		TMR	X				X		X	X	X		X	
10 to 40		TRAE+	X				X		X		X		X	
50 to 70		TRAE	X			X			X		X		X	
Constant Pressure	1/2 to 5		ACP			X				X		X	X	
Ultra-Low Temp	3/4 to 8		ZZ	X				X	X	X	X	X	X	
De-Superheating			LA	X		X				X		X	X	
			LCL	X				X	X	X	X	X	X	

Charge Code Selector

Applications	Operating Ranges									
	-50	-40	-30	-20	-10	0	+10	+20	+30	+40
R-134a/R-12 Domestic Refrigerators and Freezers, Ice Makers, Dehumidifiers, Transport Refrigeration, Medium Temperature Supermarket Equipment, Medium Temperature Commercial Equipment	MC/FC									
	MZ/FZ									
	MW35/FW35 (MOP)									
	MW55									
R-22 Residential Air Conditioners & Heat Pumps, Commercial and Industrial Chillers, Medium Temperature Supermarket Equipment, Commercial Air Handlers	HCA/HAA AIR COND. & HEAT PUMP									
	HW/HW100									
	HC									
	HW65 (MOP)									
	HZ									
R-404A/R-507/R-502 Low Temperature Cases, Ice Makers, Commercial Air Handlers, Conditioners, Soft Ice Cream Machines, Environmental Chambers	SC/RC									
	SZ/RZ									
	SW45/RW45 (MOP)									
R-410A	ZW195									

A-Series

R-410A

The A-series is used for heat pump, air conditioning, food services and commercial applications.

Features

- Stainless steel power element eliminates corrosion and prevents valve failure
- Hermetic, leak-free construction
- Compact size allows installation in limited spaces
- Mass spectrometer tested to ensure less than 0.10 oz/year external leakage rate



Options

- ZW195 charge available for R-410A systems
- Adjustable or non-adjustable superheat
- SAE or ODF connections standard – Chatleff or Aeroquip are available
- External or internal equalizer
- Internal check valve allows reverse flow for heat pump applications, eliminating the need for external piping and external check valve
- Bleed type pressure equalization to accommodate PSC type compressors
- Pressure limiting charges (MOP) available

Specifications

Maximum working pressure: 700 psig
UR/CUR file number: SA 5312

Nomenclature example: AACEB 2 HC 30 IN 3/8 x 1/2 ODF ANG

A	A	C	E	B	2	H	C	30 IN	3/8 x 1/2	ODF	ANG
Valve Series Hermetic Design	Superheat Adjustment A = Adjustable N = Non-Adjustable	Internal Check Valve (optional) Reverse Flow Bypass Application	Equalizer E=External (Omit for Internal)	Bleed Hole (optional) (Omit for no bleed hole)	Capacity Nominal Rating in Tons (See nominal capacity table below)	Refrigerant Code +F = R-12 • H = R-22 +M = R-134a • N = R-407C *P = R-507 *R = R-502 *S = R-404A Z = R-410A	Charge Code C = medium temp CA = heat pump W(MOP) = press. limiting Z = low temp AA = wide range	Capillary Tube Length 30 IN & 5 FT (std)	Inlet x Outlet Connection Sizes 1/4 x 3/8 3/8 x 1/2 1/2 x 5/8 5/8 x 7/8	Connection Type SAE=flare ODF = solder Chatleff (optional) Aeroquip (optional)	Configuration S/T = straight-thru ANG = 90° angle

+ = R-12 and R-134a are interchangeable refrigerant charges
* = R-507, R-502 and R-404A are interchangeable refrigerant charges
• = R-22 and R-407C are interchangeable refrigerant charges

AA/AN Series – Nominal* Capacity Table in Tons (kW)

R-12	R-134a	R-22	R-410A	R-502	R-507/R-404A	R-407C
-	1/8 (0.4)	1/5 (0.7)	-	-	1/8 (0.4)	1/5
1/8 (0.4)	1/4 (0.9)	1/4 (0.9)	1/4 (0.9)	1/8 (0.4)	1/4 (0.9)	1/4 (0.9)
1/4 (0.9)	1/2 (1.8)	1/2 (1.8)	1/2 (1.8)	1/4 (0.9)	1/2 (1.8)	1/2 (1.8)
1/2 (1.8)	3/4 (2.7)	1 (3.5)	1 (3.5)	1/2 (1.8)	3/4	1 (3.5)
1 (3.5)	1 (3.5)	1½ (5.3)	1½ (5.3)	1 (3.5)	1 (3.5)	1¼ (4.4)
-	1½ (5.3)	2 (7.0)	2 (7.0)	-	1¼ (4.4)	2 (7.0)
1½ (5.3)	2 (7.0)	2½ (8.8)	3 (11.0)	1½ (5.3)	2 (7.0)	2½ (8.8)
2 (7.0)	2½ (9.0)	3 (11.0)	4 (14.0)	2 (7.0)	2¼ (8.0)	3¼ (11.5)
2½ (9.0)	3 (11.0)	4 (14.0)	5 (17.0)	2½ (8.8)	2½ (8.8)	4 (14.0)
3 (11.0)	4 (14.0)	5 (17.0)	-	3 (11.0)	3½ (12.0)	5¼ (19.0)

All capacities shown are at 100°F condensing, 40°F evaporator temperature.
*See Extended Capacity Tables for ratings at a wide range of conditions per ARI standard 750.

A-Series

ANCE SAE Dimensional Data

Connection Size		A	B
Inlet	Outlet		
3/8 SAE	3/8 SAE	1.67	1.67
1/2 SAE	1/2 SAE	1.75	1.75

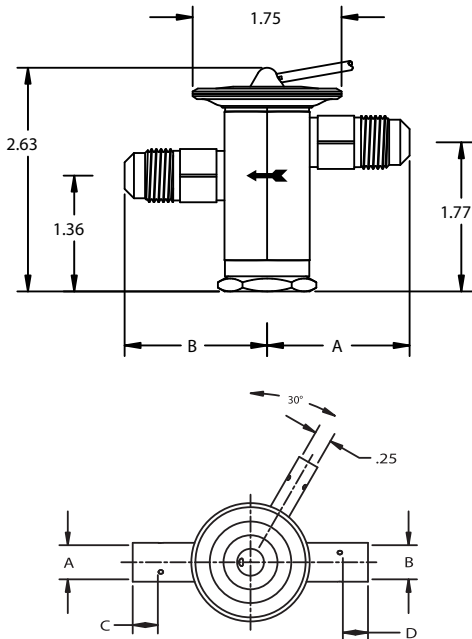

ANCE ODF Dimensional Data

Connection Size		A±.002	B±.002	C MIN	D MIN	E	F
Inlet	Outlet						
1/4 ODF	3/8 ODF	0.25	0.38	0.32	0.32	1.70	1.73
3/8 ODF	3/8 ODF	0.38	0.38	0.32	0.32	1.70	1.73
3/8 ODF	1/2 ODF	0.38	0.50	0.32	0.38	1.73	1.73
1/2 ODF	1/2 ODF	0.50	0.50	0.38	0.38	1.73	1.73
1/2 ODF	5/8 ODF	0.63	0.61	0.38	0.50	1.75	1.75

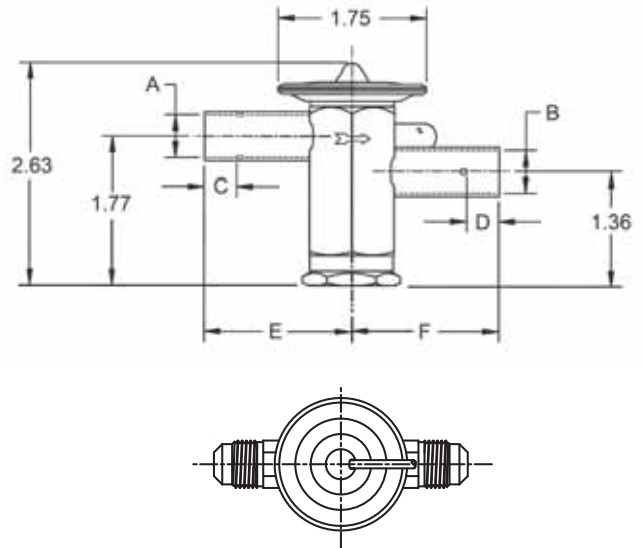

AACE SAE Dimensional Data

Connection Size		A	B
Inlet	Outlet		
3/8 SAE	3/8 SAE	1.67	1.67
1/2 SAE	1/2 SAE	1.75	1.75

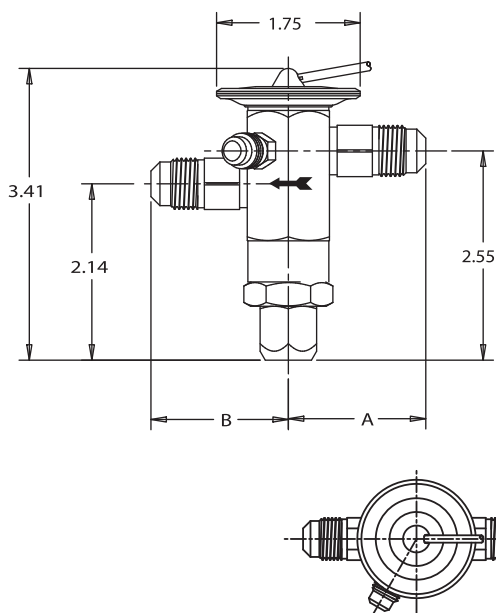

AACE ODF Dimensional Data

Connection Size		A±.002	B±.002	C MIN	D MIN	E	F
Inlet	Outlet						
1/4 ODF	3/8 ODF	0.25	0.38	0.32	0.32	1.70	1.73
3/8 ODF	3/8 ODF	0.38	0.38	0.32	0.32	1.70	1.73
3/8 ODF	1/2 ODF	0.38	0.50	0.32	0.38	1.73	1.73
1/2 ODF	1/2 ODF	0.50	0.50	0.38	0.38	1.73	1.73
1/2 ODF	5/8 ODF	0.63	0.61	0.38	0.50	1.75	1.75

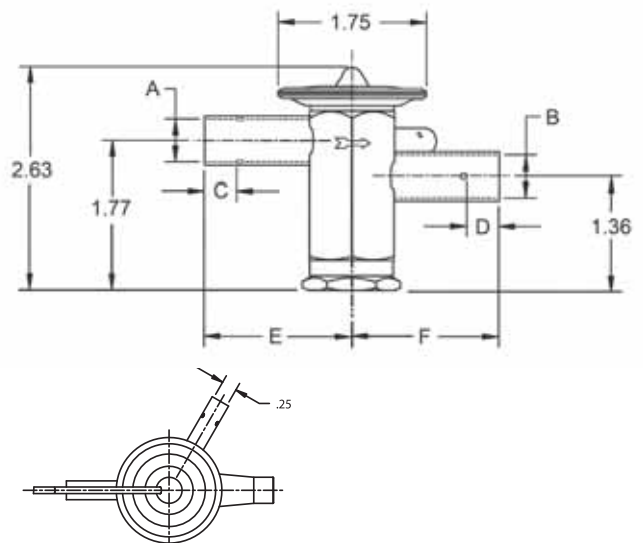

A-Series

Ordering Information

Without Internal Check Valve

Refrigerant	Series	Tons*	Charge	Connections	Cap Tube	PCN	
R-410A	AAE	1-1/2	ZW195	3/8 X 1/2 ODF S/T	30 IN	066515	
			ZW195	3/8 X 3/8 ODF S/T	30 IN	064595	
		3	ZW195	3/8 X 1/2 ODF S/T	30 IN	065579	
			ZW195	CHATLEFF	30 IN	015776	
		5	ZW195	1/2 X 5/8 ODF S/T	30 IN	065580	
			ZW195	CHATLEFF	30 IN	015794	
R-134a R-12	AA	1/8	MC	1/4 X 3/8 ODF S/T	30 IN	066030	
			MC	1/4 X 1/2 ODF S/T	30 IN	065821	
		1/4	MC	1/4 X 3/8 ODF S/T	30 IN	062051	
			MC	1/4 X 1/2 ODF S/T	5 FT	065623	
		1	MC	3/8 X 1/2 ODF S/T	30 IN	065776	
			MC	1/4 X 3/8 SAE S/T	30 IN	058985	
		1/2	MC	1/4 X 1/2 ODF S/T	5 FT	065624	
			MZ	1/4 X 3/8 SAE S/T	30 IN	058986	
		AAE	1/2	MC	1/4 X 1/2 ODF S/T	5 FT	065630
	MC			3/8 X 1/2 ODF S/T	5 FT	065631	
	1		MC	3/8 X 1/2 ODF S/T	5 FT	056315	
	R-22 R-407C	AA	1/4	HC	1/4 X 3/8 ODF S/T	5 FT	059332
				HC	1/4 X 1/2 ODF S/T	5 FT	065626
			1/2	HC	3/8 X 3/8 ODF S/T	30 IN	056547
				HC	3/8 X 1/2 SAE S/T	5 FT	057828
			1/2	HC	1/4 X 1/2 ODF S/T	5 FT	065632
				HC	3/8 X 1/2 ODF S/T	5 FT	065633
		1	HC	3/8 X 1/2 SAE ST	5 FT	057987	
HC			1/4 X 3/8 ODF ST	30 IN	059582		
HC			1/4 X 1/2 ODF S/T	5 FT	065634		
AAE		1-1/2	HC	3/8 X 1/2 ODF S/T	5 FT	064424	
			HC	3/8 X 1/2 ODF S/T	5 FT	064425	
		2	HCA	3/8 X 1/2 ODF S/T	30 IN	049632	
			HAA	3/8 X 1/2 ODF S/T	30 IN	063648	
		2-1/2	HAA	CHATLEFF	30 IN	013938	
			HCA	3/8 X 1/2 ODF S/T	30 IN	049633	
		3	HC	3/8 X 1/2 ODF S/T	5 FT	062376	
			HCA	3/8 X 1/2 SAE S/T	5 FT	056686	
			HCA	3/8 X 1/2 ODF S/T	30 IN	049634	
	4	HCA	1/2 X 5/8 ODF S/T	30 IN	060643		
		HC	1/2 X 5/8 ODF S/T	5 FT	061960		
		HCA	3/8 X 1/2 ODF S/T	30 IN	049638		
5	HCA	1/2 X 1/2 ODF S/T	30 IN	061247			
	HAA	3/8 X 1/2 ODF S/T	30 IN	063649			
	HAA	CHATLEFF	30 IN	013939			
	HC	1/2 X 5/8 ODF S/T	5 FT	059565			
	HC	5/8 X 7/8 ODF S/T	30 IN	061805			
	HCA	3/8 X 1/2 ODF S/T	30 IN	054024			
	HCA	1/2 X 5/8 ODF S/T	30 IN	059683			
AAEB	HW100	3/8 X 5/8 ODF S/T	5 FT	062088			
2	HCA	3/8 X 1/2 ODF S/T	30 IN	059616			
3	HCA	3/8 X 1/2 ODF S/T	30 IN	059603			
4	HCA	1/2 X 1/2 ODF S/T	30 IN	059605			
5	HCA	1/2 X 1/2 ODF S/T	30 IN	059607			

Chatleff Gasket Kit - KG 10045 (PCN: 066031)

* For interchangeable refrigerant charges R-134a/R-12, R-404A/R-507/R-502, and R-22/R-407C, the tons of capacity shown in the table are for the first (primary) refrigerant listed. Consult the Nominal Capacity Table for determining the tons of capacity for the secondary refrigerants listed.

Example: A 1/4 ton R-12 valve is required. What R-134a ton valve should be selected?

Solution: From the Nominal Capacity Table, a 1/2 ton R-134a valve is equivalent to a 1/4 ton R-12 valve.

Standard Product Offering

Without Internal Check Valve (cont.)

Refrigerant	Series	Tons*	Charge	Connections	Cap Tube	PCN	
R-404A R-507 R-502	AA	1/8	SC	1/4 X 3/8 ODF S/T 6A	30 IN	065921	
			SC	1/4 X 1/2 ODF S/T	30 IN	063503	
		1/4	SW45	1/4 X 3/8 ODF S/T	5 FT	065676	
			SZ	1/4 X 3/8 ODF S/T	5 FT	065675	
		1/2	SC	1/4 X 1/2 ODF S/T	30 IN	063504	
			SW45	1/4 X 1/2 ODF S/T	5 FT	065685	
			SZ	1/4 X 1/2 ODF S/T	5 FT	065682	
			SZ	3/8 X 1/2 ODF S/T	30 IN	063925	
		3/4	SC	3/8 X 1/2 ODF S/T	30 IN	066200	
			SW45	3/8 X 1/2 ODF S/T	30 IN	065686	
			SZ	3/8 X 1/2 ODF S/T	30 IN	065149	
			SZ	3/8 X 1/2 ODF S/T	30 IN	066201	
		1	SW45	3/8 X 1/2 ODF S/T	30 IN	066506	
			SZ	3/8 X 1/2 ODF S/T	30 IN	063926	
			SC	1/4 X 1/2 ODF S/T	30 IN	066422	
		AAE	1/4	SW45	1/4 X 1/2 ODF S/T	30 IN	066508
				SZ	1/4 X 1/2 ODF S/T	30 IN	066435
				SC	1/4 X 1/2 ODF S/T	30 IN	066423
	SC			3/8 X 1/2 ODF S/T	5 FT	066085	
	1/2		SW45	1/4 X 1/2 ODF S/T	5 FT	065636	
			SW45	3/8 X 1/2 ODF S/T	5 FT	065688	
			SZ	1/4 X 1/2 ODF S/T	30 IN	066436	
			SZ	3/8 X 1/2 ODF S/T	5 FT	065687	
	3/4		SC	3/8 X 1/2 ODF S/T	5 FT	066086	
			SW45	3/8 X 1/2 ODF S/T	30 IN	066509	
			SZ	1/4 X 1/2 ODF S/T	30 IN	066437	
			SC	3/8 X 1/2 ODF S/T	5 FT	066087	
	1	SW45	3/8 X 1/2 ODF S/T	5 FT	065637		
		SZ	3/8 X 1/2 ODF S/T	5 FT	065183		
		SC	3/8 X 1/2 ODF S/T	5 FT	066081		
		SW45	3/8 X 1/2 ODF S/T	5 FT	066079		
	1-1/4	SZ	3/8 X 1/2 ODF S/T	5 FT	066080		
		SC	3/8 X 1/2 ODF S/T	5 FT	066448		
		SC	3/8 X 1/2 SAE S/T	30 IN	061882		
		SW45	3/8 X 1/2 ODF S/T	5 FT	065698		
	1-1/2	SZ	3/8 X 1/2 ODF S/T	5 FT	065697		
		SC	3/8 X 1/2 ODF S/T	30 IN	065330		
		SW45	3/8 X 1/2 ODF S/T	5 FT	065690		
		SZ	3/8 X 1/2 ODF S/T	5 FT	065689		
	2	SW45	3/8 X 1/2 ODF S/T	5 FT	066082		
		SZ	3/8 X 1/2 ODF S/T	5 FT	066083		
		SC	3/8 X 1/2 ODF S/T	5 FT	066084		
		SC	3/8 X 1/2 SAE S/T	30 IN	061885		
	2-1/4	SW45	1/2 X 5/8 ODF S/T	5 FT	065148		
		SZ	1/2 X 5/8 ODF S/T	5 FT	065691		
		SC	3/8 X 1/2 ODF S/T	30 IN	066510		
		SW45	3/8 X 1/2 ODF S/T	5 FT	065693		
	2-1/2	SZ	3/8 X 1/2 ODF S/T	5 FT	065692		

With Internal Check Valve

Refrigerant	Series	Tons*	Charge	Connections	Cap Tube	PCN		
R-410A	AAE	1-1/2	ZW195	3/8 X 1/2 ODF S/T	5 FT	065871		
			ZW195	CHATLEFF	30 IN	016432		
		2	ZW195	3/8 X 1/2 ODF S/T	5 FT	065872		
			ZW195	CHATLEFF	30 IN	016615		
		3	ZW195	3/8 X 1/2 ODF S/T	5 FT	065873		
			ZW195	CHATLEFF	30 IN	015795		
		4	ZW195	3/8 X 1/2 ODF S/T	5 FT	065874		
			ZW195	CHATLEFF	30 IN	016433		
		5	ZW195	1/2 X 5/8 ODF S/T	5 FT	065875		
			ZW195	CHATLEFF	30 IN	015796		
		AAEB	1-1/2	ZW195	3/8 X 1/2 ODF S/T	30 IN	065946	
				ZW195	3/8 X 1/2 ODF S/T	30 IN	065942	
	2		ZW195	3/8 X 1/2 ODF S/T	30 IN	065943		
			ZW195	3/8 X 1/2 ODF S/T	30 IN	065944		
	3		ZW195	3/8 X 1/2 ODF S/T	30 IN	065945		
			ZW195	3/8 X 1/2 ODF S/T	30 IN	065946		
	R-22 R-407C		AAE	1	HCA	3/8 X 1/2 ODF S/T	30 IN	063795
				1-1/2	HCA	3/8 X 1/2 ODF S/T	5 FT	058923
				2	HCA	3/8 X 1/2 ODF S/T	30 IN	063676
				2-1/2	HAA	3/8 X 1/2 ODF S/T	30 IN	064102
					HAA	CHATLEFF	30 IN	014091
				3	HCA	3/8 X 1/2 ODF S/T	5 FT	065868
		4	HCA	1/2 X 5/8 ODF S/T	5 FT	065797		
			HCA	3/8 X 1/2 ODF S/T	5 FT	065869		
HAA			3/8 X 1/2 ODF S/T	30 IN	064103			
AAEB		5	HAA	1/2 X 5/8 ODF S/T	5 FT	065863		
			HAA	CHATLEFF	30 IN	014092		
		1-1/2	HCA	3/8 X 1/2 ODF S/T	30 IN	065842		
	2	HCA	3/8 X 1/2 ODF S/T	30 IN	065959			
	3	HCA	3/8 X 1/2 ODF S/T	30 IN	065941			
	4	HCA	3/8 X 5/8 ODF S/T	30 IN	065844			

AFA(E) Series

The AFA series is designed for air conditioning and commercial refrigeration applications requiring angle configuration SAE connections. The AFA is ideal for those applications requiring compact size combined with stable and accurate control over wide load and evaporator temperature ranges.

Features

- Stainless steel power element eliminates corrosion and prevents valve failure
- External superheat adjustment
- Replaceable inlet strainer
- SAE connections only
- Wrench flats on inlet and outlet



Options

- External or internal equalizer

Specifications

- Maximum working pressure: 700 psig
- UR/CUR file number: SA 5312

Nomenclature example: AFAE 1/2 HC 5 FT 3/8 x 1/2 SAE ANG

AF	A	E	1/2	H	C	5 FT	3/8 x 1/2	SAE	ANG
Valve Series Hermetic Design, Flare Connections	Superheat Adjustment A = Adjustable	Equalizer E=External (Omit for Internal)	Capacity Nominal Rating in Tons (See nominal capacity table below)	Refrigerant Code +F = R-12 • H = R-22 +M = R-134a • N = R-407C *P = R-507 *R = R-502 *S = R-404A Z = R-410A	Charge Code C = medium temp CA = heat pump W(MOP) = press. limiting Z = low temp AA = wide range	Capillary Tube Length 30 IN & 5 FT (std)	Inlet x Outlet Connection Sizes 1/4 x 3/8 3/8 x 1/2	Connection Type SAE=flare	Configuration ANG = 90° angle

+ = R-12 and R-134a are interchangeable refrigerant charges, * = R-507, R-502 and R-404A are interchangeable refrigerant charges, • = R-22 and R-407C are interchangeable refrigerant charges

AFA Series – Nominal* Capacity Table in Tons (kW)

R-12	R-134a	R-22	R-502	R-507/R-404A	R-407C
-	1/8 (0.4)	1/5 (0.7)	-	1/8 (0.4)	1/5 (0.7)
1/8 (0.4)	1/4 (0.9)	1/4 (0.9)	1/8 (0.4)	1/4 (0.9)	1/4 (0.9)
1/4 (0.9)	1/2 (1.8)	1/2 (1.8)	1/4 (0.9)	1/2 (1.8)	1/2 (1.8)
1/2 (1.8)	3/4 (2.7)	1 (3.5)	1/2 (1.8)	3/4 (2.7)	1 (3.5)
1 (3.5)	1 (3.5)	1½ (5.3)	1 (3.5)	1 (3.5)	1¼ (4.4)
-	1½ (5.3)	2 (7.0)	-	1¼ (4.4)	2 (7.0)
1½ (5.3)	2 (7.0)	2½ (9.0)	1½ (5.3)	2 (7.0)	2½ (9.0)
2 (7.0)	2½ (9.0)	3 (11.0)	2 (7.0)	2¼ (8.0)	3¼ (11.5)
-	3 (11.0)	-	-	2½ (9.0)	4 (14.0)
3 (11.0)	4 (14.0)	5 (17.0)	3 (11.0)	3½ (12.0)	5¼ (19.0)

All capacities shown are at 100°F condensing, 40°F evaporator temperature.

*See Extended Capacity Tables for ratings at a wide range of conditions per ARI standard 750.

Dimensional Data

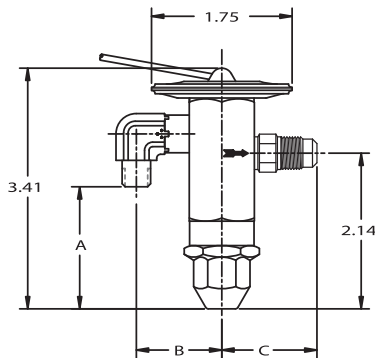

Remote Bulb Tubing Length 30" or 5' Standard

AFA(E) Connections (in)				
Inlet	Outlet	A	B	C
1/4 SAE elbow	3/8 SAE	1.56	1.31	1.64
	1/2 SAE			1.35
	5/8 SAE			1.98
3/8 SAE elbow	3/8 - 1/2 SAE	1.47	1.31	1.73
	3/8 SAE			1.34
	1/2 SAE			1.36
	5/8 SAE			1.98
	3/8 - 1/2 SAE			1.73

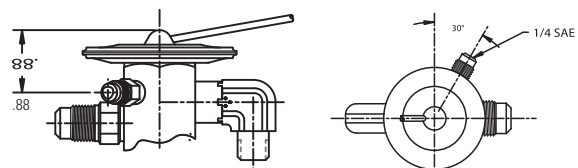

AFA(E) Series

Ordering Information

Internally Equalized							
Refrigerant	Series	Tons*	Charge	Connections	Cap Tube	PCN	
R-12	AFA	1/4	FC	1/4 X 3/8-1/2 SAE	5 FT	047753	
			FC	1/4 X 3/8-1/2 SAE	30 IN	057047	
			FC	3/8 X 3/8-1/2 SAE	5 FT	054258	
		1/2	FC	1/4 X 3/8-1/2 SAE	5 FT	047752	
			FC	1/4 X 3/8-1/2 SAE	30 IN	057028	
			FC	3/8 X 3/8-1/2 SAE	5 FT	054226	
			FC	3/8 X 3/8-1/2 SAE	30 IN	057027	
			1	FC	3/8 X 3/8-1/2 SAE	5 FT	047758
				FC	3/8 X 3/8-1/2 SAE	30 IN	057029
R-134a R-12	AFA	1/4	MC	1/4 X 3/8-1/2 SAE	5 FT	058536	
			MC	1/4 X 3/8-1/2 SAE	30 IN	057607	
		1/2	MC	1/4 X 3/8-1/2 SAE	30 IN	057606	
			MC	3/8 X 3/8-1/2 SAE	30 IN	059625	
		1	MC	1/4 X 3/8-1/2 SAE	30 IN	057605	
			MC	3/8 X 3/8-1/2 SAE	30 IN	057605	
R-22 R-407C	AFA	1/4	HC	1/4 X 3/8-1/2 SAE	30 IN	057261	
			HZ	1/4 X 3/8-1/2 SAE	30 IN	059575	
		1/2	HC	1/4 X 3/8-1/2 SAE	30 IN	057260	
			HC	3/8 X 3/8-1/2 SAE	5 FT	054229	
		1	HC	3/8 X 3/8-1/2 SAE	5 FT	054231	
			HZ	3/8 X 3/8-1/2 SAE	5 FT	057555	
		1-1/2	HC	3/8 X 3/8-1/2 SAE	5 FT	054232	
			HC	3/8 X 3/8-1/2 SAE	5 FT	054233	
		3	HC	3/8 X 3/8-1/2 SAE	5 FT	054234	
			HC	3/8 X 3/8-1/2 SAE	5 FT	054234	
R-404A R-507 R-502	AFA	1/4	SC	1/4 X 3/8-1/2 SAE	5 FT	064072	
			SW45	1/4 X 3/8-1/2 SAE	30 IN	066498	
			SZ	1/4 X 3/8-1/2 SAE	30 IN	066438	
		1/2	SC	1/4 X 3/8-1/2 SAE	30 IN	066424	
			SW45	1/4 X 3/8-1/2 SAE	30 IN	066499	
			SZ	1/4 X 3/8-1/2 SAE	30 IN	066439	
		3/4	SC	3/8 X 3/8-1/2 SAE	30 IN	066425	
			SW45	3/8 X 3/8-1/2 SAE	30 IN	066500	
			SZ	3/8 X 3/8-1/2 SAE	30 IN	066440	
		1	SC	3/8 X 3/8-1/2 SAE	30 IN	066426	
			SW45	3/8 X 3/8-1/2 SAE	30 IN	066501	
			SZ	3/8 X 3/8-1/2 SAE	30 IN	066441	

* For interchangeable refrigerant charges R-134a/R-12, R-404A/R-507/R-502, and R-22/R-407C, the tons of capacity shown in the table are for the first (primary) refrigerant listed. Consult the Nominal Capacity Table for determining the tons of capacity for the secondary refrigerants listed.

Example: A 1/4 ton R-12 valve is required. What R-134a ton valve should be selected? **Solution:** From the Nominal Capacity Table, a 1/2 ton R-134a valve is equivalent to a 1/4 ton R-12 valve.

Standard Product Offering

Ordering Information (cont.)

Externally Equalized							
Refrigerant	Series	Tons*	Charge	Connections	Cap Tube	PCN	
R-134a R-12	AFAE	1/4	MC	3/8 X 3/8-1/2 SAE	30 IN	063898	
		1/2	MC	1/4 X 3/8-1/2 SAE	30 IN	057853	
			MC	3/8 X 3/8-1/2 SAE	30 IN	061904	
		1	MC	3/8 X 3/8-1/2 SAE	30 IN	057613	
		1-1/2	MC	3/8 X 3/8-1/2 SAE	30 IN	060865	
		2	MC	3/8 X 3/8-1/2 SAE	30 IN	061906	
R-22 R-407C	AFAE	1/2	HC	1/4 X 3/8-1/2 SAE	5 FT	054243	
		1	HC	3/8 X 3/8-1/2 SAE	5 FT	054246	
			HC	1/4 X 3/8-1/2 SAE	5 FT	054245	
			HZ	3/8 X 3/8-1/2 SAE	5 FT	057163	
		1-1/2	HC	3/8 X 3/8-1/2 SAE	5 FT	054247	
			HZ	3/8 X 3/8-1/2 SAE	5 FT	057950	
		2	HZ	3/8 X 3/8-1/2 SAE	5 FT	057951	
			HC	3/8 X 3/8-1/2 SAE	5 FT	054248	
		3	HC	3/8 X 3/8-1/2 SAE	5 FT	054249	
			HZ	3/8 X 3/8-1/2 SAE	5 FT	057556	
		5	HC	3/8 X 3/8-1/2 SAE	5 FT	054250	
			HZ	3/8 X 3/8-1/2 SAE	5 FT	058484	
R-404A R-507 R-502	AFAE	1/4	SC	1/4 X 3/8-1/2 SAE	30 IN	066427	
			SW45	1/4 X 3/8-1/2 SAE	30 IN	066502	
			SZ	1/4 X 3/8-1/2 SAE	30 IN	066442	
		1/2	SC	1/4 X 3/8-1/2 SAE	30 IN	066428	
			SW45	3/8 X 3/8-1/2 SAE	30 IN	066453	
			SW45	1/4 X 3/8-1/2 SAE	30 IN	066503	
		3/4	SZ	1/4 X 3/8-1/2 SAE	30 IN	066443	
			SC	3/8 X 3/8-1/2 SAE	30 IN	061911	
			SW45	3/8 X 3/8-1/2 SAE	30 IN	066504	
		1	SZ	1/4 X 3/8-1/2 SAE	30 IN	066444	
			SC	3/8 X 3/8-1/2 SAE	30 IN	061912	
			SW45	3/8 X 3/8-1/2 SAE	30 IN	066452	
		1-1/2	SZ	1/4 X 3/8-1/2 SAE	30 IN	066445	
			SZ	3/8 X 3/8-1/2 SAE	5 FT	063464	
			SC	3/8 X 3/8-1/2 SAE	5 FT	066454	
		2	SZ	3/8 X 3/8-1/2 SAE	5 FT	063465	
			SC	3/8 X 3/8-1/2 SAE	30 IN	061914	
			SW45	3/8 X 3/8-1/2 SAE	5 FT	066505	
				SZ	3/8 X 3/8-1/2 SAE	5 FT	061646

* For interchangeable refrigerant charges R-134a/R-12, R-404A/R-507/R-502, and R-22/R-407C, the tons of capacity shown in the table are for the first (primary) refrigerant listed. Consult the Nominal Capacity Table for determining the tons of capacity for the secondary refrigerants listed.

Example: A 1/4 ton R-12 valve is required. What R-134a ton valve should be selected? **Solution:** From the Nominal Capacity Table, a 1/2 ton R-134a valve is equivalent to a 1/4 ton R-12 valve.

Standard Product Offering

NXT Series

R-410A

The Emerson NXT Series is a balanced ported valve designed for high efficiency R-410A air conditioning and heat pump applications. NXT Series valves operate over a wide range of conditions and applications, while offering excellent performance, superior reliability, and unparalleled valve life.

Features

- Precision superheat control optimized for R-410 A systems
- Enhanced power element design offers extended valve life
- Stainless steel power element eliminates corrosion and prevents valve failure
- Laser etched identification markings for permanent legibility
- Hermetic, leak-free construction of all joints
- Compact size allows installation in limited spaces
- Bi-Flow capability allows one valve to control the superheat in both cooling and heating modes for close-coupled or packaged heat pump applications
- Balanced port construction compensates for changes in operating pressures due to varying ambients, gas defrost, heat reclaim, or widely varying evaporator loads
- External equalizer is standard
- Screens on ODF inlet connections

Specifications

- Maximum working pressure (MWP): 700 psig
- R-410A operating range: -20°F to +50°F
- UR/CUR file number: SA 5312

Nomenclature example: NAE 3 ZAA ODF B15%

N	A	E	3	ZAA	ODF	B15%
NXT Series	Body Type A = Adjustable, With Check, Straight-Through B = Adjustable, No Check, Straight-Through C = Non-Adjustable, With Check, Straight-Through D = Non-Adjustable, No Check, Straight-Through	Equalizer E = External Equalizer	Capacity (In Tons)	Refrigerant Code ZAA = R-410A	Connection Type ODF = Solder CHA = Chatleff	Bleed % (Omit for None)



Non-Adjustable

Adjustable

Options

- High flow internal check valve allows reverse flow for heat pump applications, eliminating the need for external check valve and improving overall system efficiency
- Adjustable or non-adjustable superheat
- Bleed type pressure equalization available to accommodate PSC type compressors
- ODF connections are standard - Chatleff connections are available
- External equalizer (1/4" ODF) is a standard offering. Other configurations are available
- External equalizer 1/8" tube with 45° end cut is a standard offering - other terminations are available

NXT Series R-410A

Ordering Information

Adjustable, Straight-through body style, Individually packaged

Refrigerant	Capacity (Tons)	Check Valve	Bleed	Inlet X Outlet	Bulb Cap Tube Length	External Equalizer	PCN
R-410A	1/2		15%	3/8 ODF X 3/8 ODF	30"	30" With Angle Cut	095064
			-	3/8 ODF X 3/8 ODF	30"	30" With Angle Cut	095065
	1	√	-	3/8 ODF X 1/2 ODF	30"	1/4" ODF	095066
		√	15%	3/8 ODF X 1/2 ODF	5 ft	1/4" ODF	095000
		√	-	Chatleff X Chatleff	5 ft	1/4" ODF	095001
		√	-	3/8 ODF X 1/2 ODF	5 ft	5 ft With 1/4" SAE Flare Nut	095002
		√	-	3/8 ODF X 1/2 ODF	5 ft	5 ft With Angle Cut	095003
		√	15%	3/8 ODF X 1/2 ODF	5 ft	1/4" ODF	095004
	1-1/2	√	-	3/8 ODF X 1/2 ODF	5 ft	1/4" ODF	095005
		√	15%	3/8 ODF X 1/2 ODF	5 ft	1/4" ODF	095006
		√	-	Chatleff X Chatleff	5 ft	1/4" ODF	095007
		√	-	3/8 ODF X 1/2 ODF	5 ft	5 ft With 1/4" SAE Flare Nut	095008
		√	-	3/8 ODF X 1/2 ODF	5 ft	5 ft With Angle Cut	095009
		√	15%	3/8 ODF X 1/2 ODF	5 ft	1/4" ODF	095010
	2	√	-	3/8 ODF X 1/2 ODF	5 ft	1/4" ODF	095011
		√	15%	3/8 ODF X 1/2 ODF	5 ft	1/4" ODF	095012
		√	-	Chatleff X Chatleff	5 ft	1/4" ODF	095013
		√	-	3/8 ODF X 1/2 ODF	5 ft	5 ft With 1/4" SAE Flare Nut	095014
		√	-	3/8 ODF X 1/2 ODF	5 ft	5 ft With Angle Cut	095015
		√	15%	3/8 ODF X 1/2 ODF	5 ft	1/4" ODF	095016
	3	√	-	3/8 ODF X 1/2 ODF	5 ft	1/4" ODF	095017
		√	15%	3/8 ODF X 1/2 ODF	5 ft	1/4" ODF	095018
		√	-	Chatleff X Chatleff	5 ft	1/4" ODF	095019
		√	-	3/8 ODF X 1/2 ODF	5 ft	5 ft With 1/4" SAE Flare Nut	095020
		√	-	3/8 ODF X 1/2 ODF	5 ft	5 ft With Angle Cut	095021
		√	15%	3/8 ODF X 1/2 ODF	5 ft	1/4" ODF	095022
	4	√	-	3/8 ODF X 1/2 ODF	5 ft	1/4" ODF	095023
		√	15%	3/8 ODF X 1/2 ODF	5 ft	1/4" ODF	095024
		√	-	Chatleff X Chatleff	5 ft	1/4" ODF	095025
		√	-	3/8 ODF X 1/2 ODF	5 ft	5 ft With 1/4" SAE Flare Nut	095026
		√	-	3/8 ODF X 1/2 ODF	5 ft	5 ft With Angle Cut	095027
		√	15%	3/8 ODF X 1/2 ODF	5 ft	1/4" ODF	095028
	5	√	-	3/8 ODF X 1/2 ODF	5 ft	1/4" ODF	095029
		√	15%	3/8 ODF X 1/2 ODF	5 ft	1/4" ODF	095030
		√	-	1/2 ODF X 5/8 ODF	5 ft	1/4" ODF	095031
		√	-	1/2 ODF X 5/8 ODF	5 ft	1/4" ODF	095032
		√	-	Chatleff X Chatleff	5 ft	5 ft With 1/4" SAE Flare Nut	095033
		√	15%	1/2 ODF X 5/8 ODF	5 ft	5 ft With Angle Cut	095034
	6	√	-	1/2 ODF X 5/8 ODF	5 ft	1/4" ODF	095035
		√	15%	1/2 ODF X 5/8 ODF	5 ft	1/4" ODF	095036
		√	-	Chatleff X Chatleff	5 ft	1/4" ODF	095037
		√	-	1/2 ODF X 5/8 ODF	5 ft	5 ft With 1/4" SAE Flare Nut	095038
		√	-	1/2 ODF X 5/8 ODF	5 ft	5 ft With Angle Cut	095039
		√	15%	1/2 ODF X 5/8 ODF	5 ft	1/4" ODF	095040
	7	√	-	1/2 ODF X 5/8 ODF	5 ft	1/4" ODF	095041
		√	15%	1/2 ODF X 5/8 ODF	5 ft	1/4" ODF	095042
		√	-	5/8 ODF X 7/8 ODF	5 ft	1/4" ODF	095043
		√	-	Chatleff X Chatleff	5 ft	5 ft With 1/4" SAE Flare Nut	095044
		√	-	5/8 ODF X 7/8 ODF	5 ft	5 ft With Angle Cut	095045
		√	15%	5/8 ODF X 7/8 ODF	5 ft	1/4" ODF	095046
8	√	-	5/8 ODF X 7/8 ODF	5 ft	1/4" ODF	095047	
	√	15%	5/8 ODF X 7/8 ODF	5 ft	1/4" ODF	095048	
	√	-	5/8 ODF X 7/8 ODF	5 ft	1/4" ODF	095049	
	√	-	5/8 ODF X 7/8 ODF	5 ft	1/4" ODF	095050	
	√	15%	5/8 ODF X 7/8 ODF	5 ft	1/4" ODF	095051	
	√	-	1/2 ODF X 5/8 ODF	5 ft	1/4" ODF	095060	
12	√	-	5/8 ODF X 7/8 ODF	5 ft	1/4" ODF	095052	
	√	15%	5/8 ODF X 7/8 ODF	5 ft	1/4" ODF	095053	
	√	-	5/8 ODF X 1-1/8 ODF	5 ft	1/4" ODF	095054	
	√	-	7/8 ODF X 1-1/8 ODF	5 ft	1/4" ODF	095055	
	√	-	5/8 ODF X 7/8 ODF	5 ft	1/4" ODF	095056	
	√	15%	5/8 ODF X 7/8 ODF	5 ft	1/4" ODF	095057	
15	√	-	5/8 ODF X 1-1/8 ODF	5 ft	1/4" ODF	095058	
	√	-	7/8 ODF X 1-1/8 ODF	5 ft	1/4" ODF	095059	

NXT Series Dimensional Data (in)

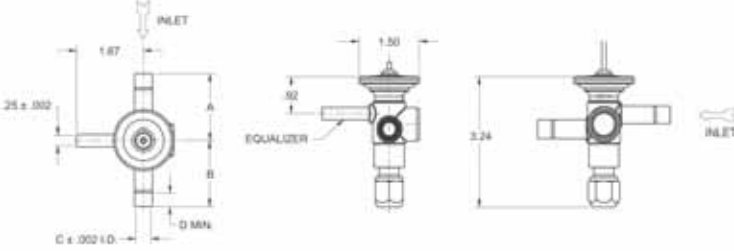

Adjustable - ODF Connections with 1/4 ODF Equalizer Shown

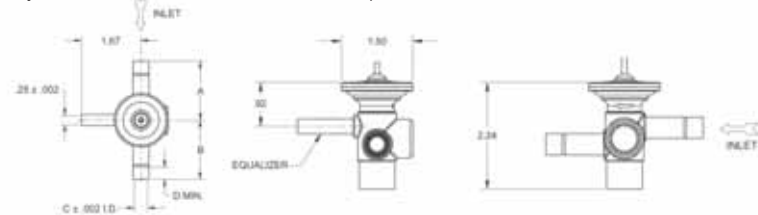

Non-Adjustable - ODF Connections with 1/4 ODF Equalizer Shown

Connections	Dimension			
	A	B	C	D
3/8 ODF	1.65	1.65	0.379	0.34
1/2 ODF	1.65	1.65	0.504	0.48
5/8 ODF	2.15	2.15	0.629	0.75
7/8 ODF	2.15	2.15	0.879	0.75
Chatleff	1.80	1.36	-	-

TXV Connect Kits

Emerson™ TXV Connect kits include our latest generation thermal expansion valves plus chattleff and aeroquip adapters that are easy to install into all residential air conditioning systems.



Features

- ODF TXVs with chatleff and aeroquip adapters
- One valve to fit all systems
- TXV with internal check, bulb strap, and connection options all in one box
- R-410A and R-22 kits in multiple capacities
- Easy field replacement of fixed orifice for increased efficiency

Specifications

- Maximum Working Pressure (MWP): 700 psig
- UL File number (valves): SA 5312

Individual adapter kits

PCN	Description	Capacity(tons)*	Refrigerant
066657	TXV + CONNECT 2½T R-22	1-1/2 to 3	R-22
066658	TXV + CONNECT 5T R-22	3-1/2 to 5	
066660	TXV + CONNECT 1½T R-410A	1-1/2	R-410A
066661	TXV + CONNECT 2T R-410A	2	
066662	TXV + CONNECT 3T R-410A	3	
066663	TXV + CONNECT 4T R-410A	4	
066664	TXV + CONNECT 5T R-410A	5	
066653	CHATLEFF ADAPTER ASSEMBLY	N/A	N/A
066654	AEROQUIP ADAPTER ASSEMBLY	N/A	N/A

* For extended capacity tables, use NXT series for R-410A applications and A-Series for R-22

Dimension Data

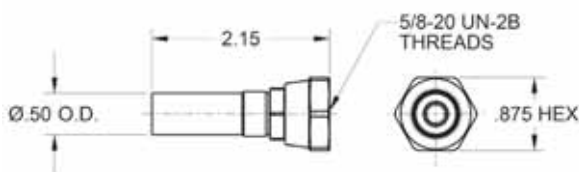

Aeroquip Adapter Assembly

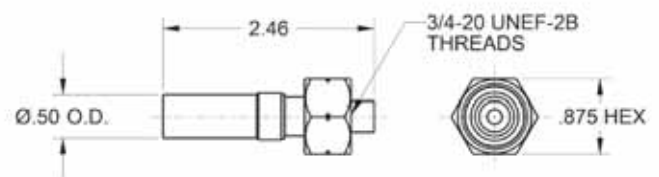

Chatleff Adapter Assembly

HF/HFK Series

The HF series is a balanced ported valve designed for refrigeration, air conditioning and heat pump applications.

Features

- Stainless steel replaceable power element eliminates corrosion and prevents valve failure
- Two body sizes provide capacities from 1/4 to 20 tons

Standard Body – HF & HFK

- The HF is offered several ways:
 - *Pre-packaged HFK service kits* – Include a mix of bodies and power elements with a complete set of cages to serve the most applications with a minimum of parts
 - *Individual components* – Bodies, cages, & power elements may be ordered separately
 - *Finished valves* – Assembled valves ready for immediate installation
- Bi-Flow capability up to 5-1/2 tons R-22 allows one valve to control the superheat in both cooling and heating modes

Extended Body – HF

- Capacity range from 8 to 20 tons (R-22)
- Finished valve only



NOTE: If the HF body is stamped HFK, then the cage is replaceable.

Options

- ODF or SAE connections
- Straight-through or angle flow configurations
- Removable inlet strainer (ODF only)
- Internal or external equalizer

Specifications

- Maximum working pressure: 450 psig
- UR/CUR file number: SA 5312

Nomenclature example: HFESC 2 HC 5 FT 3/8 x 1/2 ODF S/T

HF	N	E	S	C	B	2	H	C	5 FT	3/8 x 1/2	ODF	S/T
Valve Series Balanced Port Design	Superheat Adjustment N = Non-Adjustable Omit for Adjustable	Equalizer E=External (Omit for Internal)	Connection Type S = Solder (Omit for SAE Flare)	Removable Inlet Strainer (optional) C = Inlet Strainer (ODF only)	Bleed Hole (optional) (Omit for no bleed hole)	Capacity Nominal Rating in Tons (See nominal capacity table below)	Refrigerant Code +F = R-12 • H = R-22 +M = R-134a • N = R-407C * P = R-507 * R = R-502 * S = R-404A	Charge Code C = medium temp CA = heat pump W(MOP) = press. limiting Z = low temp AA = wide range	Capillary Tube Length 5 FT (std)	Inlet x Outlet Connection Sizes 1/4 x 3/8 3/8 x 1/2	Connection Type SAE = flare ODF = solder	Configuration ANG = 90° angle S/T = straight-thru

- + = R-12 and R-134a are interchangeable refrigerant charges
- * = R-507, R-502 and R-404A are interchangeable refrigerant charges
- = R-22 and R-407C are interchangeable refrigerant charges

HF Series-Nominal* Capacity Tables in Tons (kW)

Standard Body HF

R-12	R-134a	R-22/R-407C	R-502/R-404A/R-507
1/8 (0.4)	1/4 (0.9)	1/4 (0.9)	1/8 (0.4)
1/4 (0.9)	1/2 (1.8)	1/2 (1.8)	1/4 (0.9)
1/2 (1.8)	3/4 (2.7)	1 (3.5)	1/2 (1.8)
1 (3.5)	1 (3.5)	1 1/2 (5.3)	1 (3.5)
1 1/4 (4.4)	1 1/2 (5.3)	2 (7.0)	1 1/4 (4.4)
1 1/2 (5.3)	1 3/4 (6.2)	2 1/2 (8.8)	1 1/2 (5.3)
2 (7.0)	2 1/2 (8.8)	3 (11.0)	2 (7.0)
3 1/2 (12.0)	4 (14.0)	5 1/2 (20.0)	3 1/2 (12.0)

Extended Body HF

R-12	R-134a	R-22/R-407C	R-502/R-404A/R-507
5 (17.0)	6(21.0)	8 (28.0)	5 (17.0)
6 (21.0)	7 1/2 (27.0)	10 (35.0)	7 (27.0)
9 (32.0)	11 (39.0)	15 (53.0)	10 (35.0)
12 (42.0)	14 (50.0)	20 (70.0)	13 (46.0)

All capacities shown are at 100°F condensing, 40°F evaporator temperature.
*See Extended Capacity Tables for ratings at a wide range of conditions per ARI standard 750.

HF/HFK Series

Dimensional Data

Standard Body HF

¼ thru 5½ tons R-22

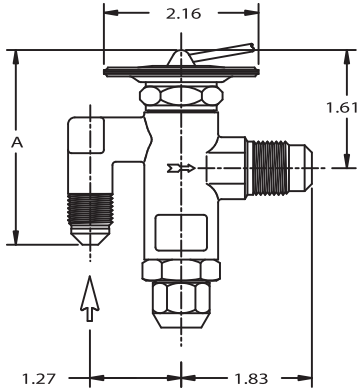

SAE

HF SAE

Connection Size		A	B	C
Inlet	Outlet			
1/4 SAE	1/2 SAE	3.11	1.27	1.83
3/8 SAE	1/2 SAE	2.72		

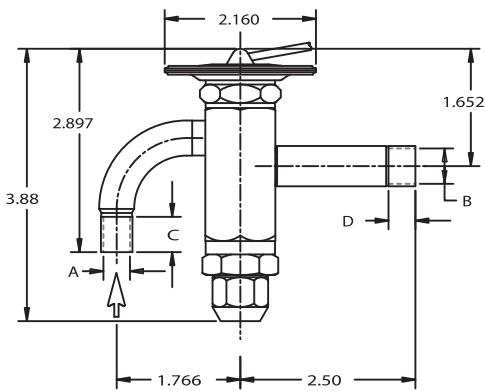

ODF

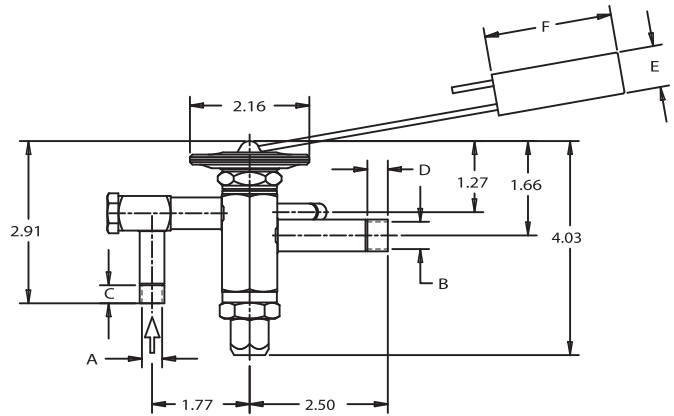

ODF
w/optional strainer
at inlet

Extended Body HF

8, 10, 15 & 20 ton R-22

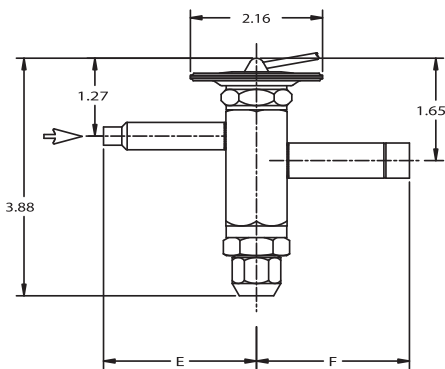

ODF

HF ODF

Connection Size		A±	B±	C	D	E	F
Inlet	Outlet	.002	.002	MIN	MIN		
1/4 ODF	3/8 ODF	0.25	0.38	0.31	0.31	2.50	2.50
3/8 ODF	1/2 ODF	0.25	0.50	0.31	0.37		
3/8 ODF	1/2 ODF	0.38	0.50	0.37	0.37		

Thermal Expansion Valves
TXV Extended Capacity Tables
EX Valves and Controls
Solenoid Valves and Coils
Solenoid Capacity Tables
Industrial Solenoid Valves
Shut Off Valves
System Protectors
System Protectors Capacity Tables
Oil Controls
Temperature Pressure Controls

HF/HFK Series

Ordering Information

Use the following tables to order individual components.

HFK Body Selection Table

PCN	Description	Type	Connections (Inlet x Outlet)
064881	KT-20298-1	HFK	1/4 x 1/2 SAE Ang Inlet
064882	KT-20298-2	HFK	3/8 x 1/2 SAE Ang Inlet
064883	KT-20298-3	HFKE	1/4 x 1/2 SAE Ang Inlet
064884	KT-20298-4	HFKE	3/8 x 1/2 SAE Ang Inlet
064885	KT-20298-5	HFKSC	3/8 x 1/2 ODF Ang Inlet w/ Strainer
064886	KT-20298-6	HFKESC	3/8 x 1/2 ODF Ang Inlet w/ Strainer
064887	KT-20298-7	HFKS	3/8 x 1/2 ODF S/T
064888	KT-20298-8	HFKS	3/8 x 5/8 ODF S/T
064889	KT-20298-9	HFKS	1/2 x 5/8 ODF S/T
064890	KT-20298-10	HFKS	1/2 x 7/8 ODF S/T
064891	KT-20298-11	HFKES	3/8 x 1/2 ODF S/T
064892	KT-20298-12	HFKES	3/8 x 5/8 ODF S/T
064895	KT-20298-13	HFKES	1/2 x 5/8 ODF S/T
064896	KT-20298-14	HFKES	1/2 x 7/8 ODF S/T

Standard Product Offering

HF & HFK Power Element Table

PCN	Description	System Refrigerant(s)	Application
053769	X26300-FW15-1	R-134a/R-12	Low Temp MOP
054798	X26300-FW35-1	R-134a/R-12	Low Temp MOP
063869	X26300-FW55-1	R-134a/R-12	Low Temp MOP
053766	X26300-FZ-1	R-134a/R-12	Low Temp
053763	X26300-FC-1	R-134a/R-12	Medium Temp
058074	X26300-MC-1	R-134a	Medium Temp
053767	X26300-HZ-1	R-22/R-407C	Low Temp
057834	X26300-HCA-1	R-22/R-407C	Heat Pump
057764	X26300-HW100-1	R-22/R-407C	AC MOP
053764	X26300-HC-1	R-22/R-407C	A/C Med. Temp
058085	X26300-SW45-1	R-404/ R-507/ R-502	Low Temp MOP
058082	X26300-SZ-1	R-404/ R-507/ R-502	Low Temp
058083	X26300-SC-1	R-404/ R-507/ R-502	Medium Temp

Standard Product Offering

HFK Cage Nominal* Capacity Table

PCN	Description ¹	Cage Code	R-12	R-22	R-134a	R-404	R-507	R-502	R-407C
064868	KT-20299-0	0	1/8	1/4	1/4	1/8	1/8	1/8	1/4
064869	KT-20299-1	1	1/4	1/2	1/2	1/4	1/4	1/4	1/2
064870	KT-20299-2	2	1/2	1	3/4	1/2	1/2	1/2	1
064871	KT-20299-3	3	1	1 1/2	1	1	1	1	1 1/2
064872	KT-20299-4	4	1 1/4	2	1 1/2	1 1/4	1 1/4	1 1/4	2
064873	KT-20299-5	5	1 1/2	2 1/2	1 3/4	1 1/2	1 1/2	1 1/2	2 1/2
064874	KT-20299-6	6	2	3	2 1/2	2	2	2	3
064875	KT-20299-7	7	3 1/2	5 1/2	4	3 1/2	3 1/2	3 1/2	5 1/2

¹ Cage Kit includes Cage, Insertion Tool and ID Clips.
 *All capacities shown are at 100°F condensing, 40°F evaporator temperature.
 See Extended Capacity Tables for ratings at a wide range of conditions per ARI standard 750.

Standard Product Offering

Replacement Parts – SAE Inlet

PCN	Part Number	Description
027385	X-11176-1	Filter Screen
058707	27676-1	Seal Cap

Replacement Parts- HFSC & HFESC Only

PCN	Kit Number	Description
057686	KT-20264	Includes seal cap, gasket o-ring, screen, spring

Cage Kit (PCN 064879)

Item	Qty
Size 0 Cage (1/4 ton R-22)	2
Size 1 Cage (1/2 ton R-22)	2
Size 2 Cage (1 ton R-22)	2
Size 3 Cage (1 1/2 ton R-22)	2
Size 4 Cage (2 ton R-22)	2
Size 5 Cage (2 1/2 ton R-22)	2
Size 6 Cage (3 ton R-22)	2
Size 7 Cage (5 1/2 ton R-22)	2
Insertion Tool	1
Oil Bottle	1
Cage ID Tags	16

HFK Accessories

PCN	Description
064897	Cage Box (Empty)
064898	Insertion Tool
064899	Oil Bottle
065203	Cage Gasket Kit (12 sets)

Standard Product Offering

HF/HFK Series

Ordering Information

HFK Pre-Packaged Kits

The HFK is a pre-packaged kit consisting of a mix of popular bodies and power elements with a complete selection of cages. These kits provide great flexibility allowing valves to be assembled as needed for each application. Three kits are provided as shown below, along with the cage kit which is included in each pre-packaged kit. In addition, custom kits can be assembled by stocking an empty kit case with desired components.



SAE/ODF Kit (PCN 065135)

Item	Qty
HFK 3/8 x 1/2 SAE ANG	1
HFKE 3/8 x 1/2 SAE ANG	1
HFKS 3/8 x 1/2 ODF S/T	1
HFKES 3/8 x 1/2 ODF S/T	1
Cage Kit (PCN 064879)	1
Insertion Tool (PCN 064898)	1
Service Box	1
FC Power Element	1
FZ Power Element	1
HC Power Element	1
HZ Power Element	1
SC Power Element	1
SW45 Power Element	1

SAE Kit (PCN 064876)

Item	Qty
HFK 1/4 X 1/2 Body	1
HFK 3/8 X 1/2 Body	1
HFKE 3/8 X 1/2 Body	2
FC Power Element	2
HC Power Element	1
HZ Power Element	1
SZ Power Element	2
Cage Kit (PCN 064879)	1

ODF Kit (PCN 064877)

Item	Qty
HFKSC 3/8 X 1/2 Body	1
HFKE 3/8 X 1/2 Body	1
HFKESC 3/8 X 1/2 Body	2
FC Power Element	2
HC Power Element	1
HZ Power Element	1
SZ Power Element	2
Cage Kit (PCN 064879)	1

Cage Kit (PCN 064879)

Item	Qty
Size 0 Cage (1/4 ton R-22)	2
Size 1 Cage (1/2 ton R-22)	2
Size 2 Cage (1 ton R-22)	2
Size 3 Cage (1 1/2 ton R-22)	2
Size 4 Cage (2 ton R-22)	2
Size 5 Cage (2 1/2 ton R-22)	2
Size 6 Cage (3 ton R-22)	2
Size 7 Cage (5 1/2 ton R-22)	2
Insertion Tool	1
Oil Bottle	1
Cage ID Tags	16

HFK Assembly Procedure (see 6 assembly steps & diagrams below)

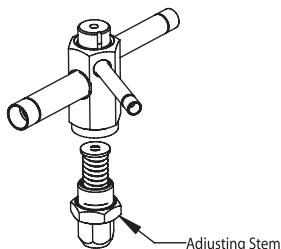

1. Remove adjusting stem assembly from body with 15/16" wrench.

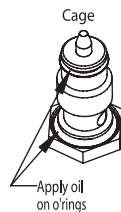

2. Lubricate both o-rings on cage.

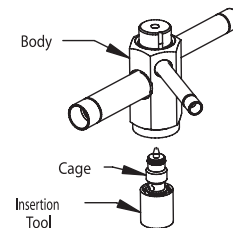

3. Insert cage into body with driver and insertion tool and hand tighten. (Do not over-tighten)

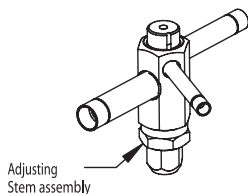

4. Replace adjustment stem assembly to body and hand tighten. Use the 15/16" wrench to tighten adjustment stem assembly 60° or one wrench flat. (300-360 inch lbs. - Do not over-tighten)

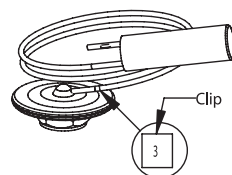

5. Attach cage identification clip on power element cap tube.

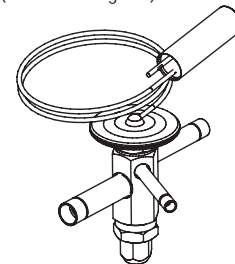

6. Screw power element to top of valve body and hand tighten. Use the 1" wrench to tighten power element 60° or one wrench flat. (300-360 inch lbs. - Do not over-tighten)

HF/HFK Series

Ordering Information

Use the following tables to order factory assembled valves.

HF Series – Internally Equalized						
Refrigerant	Series	Tons*	Charge	Connections	Cap Tube	PCN
R-12	HF HFS	1/4	FC	1/4 X 1/2 SAE ANG	5 FT	009811
			FC	3/8 X 1/2 SAE ANG	5 FT	054134
		1/2	FC	1/4 X 1/2 SAE ANG	5 FT	009810
			FC	3/8 X 1/2 ODF ANG	5 FT	056063
			FC	3/8 X 1/2 ODF S/T	5 FT	056013
			FC	3/8 X 1/2 SAE	5 FT	054966
			FC	3/8 X 1/2 SAE ANG	5 FT	054892
		1	FC	3/8 X 1/2 ODF S/T	5 FT	056119
			FC	3/8 X 1/2 SAE ANG	5 FT	057619
		1-1/2	FC	3/8 X 1/2 SAE ANG	5 FT	054914
2	FC	3/8 X 1/2 SAE	5 FT	053060		
R-134a R-12	HF HFS	1/4	MC	3/8 X 1/2 ODF ANG	5 FT	058545
			MC	3/8 X 1/2 SAE ANG	5 FT	057618
		1/2	MC	3/8 X 1/2 ODF S/T	5 FT	058100
MC	3/8 X 1/2 SAE ANG		5 FT	057620		
1	MC	3/8 X 1/2 ODF S/T	5 FT	065641		
R-22 R-407C	HF HFS	1/4	HC	1/4 X 1/2 SAE ANG	5 FT	058430
			HC	3/8 X 1/2 ODF ANG	5 FT	055493
			HC	3/8 X 1/2 ODF S/T	5 FT	055633
			HC	3/8 X 1/2 SAE	5 FT	054921
			HZ	1/4 X 1/2 SAE ANG	5 FT	059653
			HZ	3/8 X 1/2 ODF S/T	5 FT	056169
		1/2	HC	1/4 X 1/2 SAE ANG	5 FT	009812
			HC	3/8 X 1/2 ODF ANG	5 FT	054723
			HC	3/8 X 1/2 ODF S/T	5 FT	054136
			HC	3/8 X 1/2 SAE	5 FT	054135
			HZ	3/8 X 1/2 SAE	5 FT	054364
			HC	3/8 X 1/2 ODF ANG	5 FT	055702
		1	HC	3/8 X 1/2 ODF S/T	5 FT	055928
			HC	3/8 X 1/2 SAE	5 FT	054927
			HZ	3/8 X 1/2 SAE	5 FT	054928
			HC	3/8 X 1/2 ODF ANG	5 FT	055969
		1-1/2	HC	3/8 X 1/2 ODF S/T	5 FT	056018
			HC	3/8 X 1/2 SAE	5 FT	054933
			HC	3/8 X 1/2 SAE	5 FT	054939
		2	HZ	3/8 X 1/2 SAE ANG	5 FT	054940
			HC	3/8 X 1/2 SAE	5 FT	054947
		2-1/2	HC	3/8 X 1/2 SAE	5 FT	053316
			HC	3/8 X 1/2 ODF S/T	5 FT	053915

Standard Product Offering

HF/HFK Series

Ordering Information (continued)

Use the following tables to order factory assembled valves.

HF Series – Internally Equalized						
Refrigerant	Series	Tons*	Charge	Connections	Cap Tube	PCN
R-404A R-507 R-502	HF HFS	1/4	SC	1/4 X 1/2	30 IN	066516
			SW45	1/4 X 1/2	30 IN	066517
			SZ	1/4 X 1/2	30 IN	066518
		1/2	SC	1/4 X 1/2	30 IN	066519
			SW45	1/4 X 1/2	30 IN	066520
			SZ	1/4 X 1/2	30 IN	066521
		1	SC	3/8 X 1/2 ODF S/T	5 FT	065643
			SW45	3/8 X 1/2	5 FT	066522
			SZ	3/8 X 1/2	5 FT	066523
		1-1/2	SC	3/8 X 1/2	5 FT	066524
			SW45	3/8 X 1/2	5 FT	066525
			SZ	3/8 X 1/2	5 FT	066526
		2	SC	3/8 X 1/2	5 FT	066527
			SW45	3/8 X 1/2	5 FT	066528
			SZ	3/8 X 1/2	5 FT	066529
		3-1/2	SC	3/8 X 1/2	5 FT	066530
			SW45	3/8 X 1/2	5 FT	066531
			SZ	3/8 X 1/2	5 FT	066532
R-502	HF HFS	1/4	RC	1/4 X 1/2 SAE ANG	5 FT	059304
			RC	3/8 X 1/2 ODF ANG	5 FT	055490
			RC	3/8 X 1/2 SAE	5 FT	054137
			RZ	1/4 X 3/8 ODF S/T	5 FT	055792
			RZ	3/8 X 1/2 ODF S/T	5 FT	056228
			RZ	3/8 X 1/2 SAE	5 FT	054369
		1/2	RC	3/8 X 1/2 SAE	5 FT	054964
			RZ	3/8 X 1/2 ODF ANG	5 FT	055874
			RZ	3/8 X 1/2 ODF S/T	5 FT	056008
		1	RZ	3/8 X 1/2 SAE	5 FT	054965
			RC	3/8 X 1/2 SAE	5 FT	054976
			RC	3/8 X 1/2 SAE ANG	5 FT	054905
		1-1/2	RZ	3/8 X 1/2 ODF ANG	5 FT	055785
			RZ	3/8 X 1/2 SAE	5 FT	054977
			RC	3/8 X 1/2 SAE	5 FT	054984
		2	RZ	3/8 X 1/2 SAE	5 FT	054986
			RC	3/8 X 1/2 SAE	5 FT	053061
		3-1/2	RC	3/8 X 1/2 SAE	5 FT	055936

Standard Product Offering

HF/HFK Series

Ordering Information (continued)

HF Series – Externally Equalized (continued)

Refrigerant	Series	Tons*	Charge	Connections	Cap Tube	PCN
R-12	HFE HFES	1/4	FC	3/8 X 1/2 SAE ANG	5 FT	054360
		1/2	FC	1/4 X 1/2 SAE ANG	5 FT	009955
			FC	3/8 X 1/2 ODF ANG	5 FT	056021
			FC	3/8 X 1/2 ODF S/T	5 FT	056331
			FC	3/8 X 1/2 SAE ANG	5 FT	054895
		1	FC	3/8 X 1/2 ODF ANG	5 FT	055993
			FC	3/8 X 1/2 ODF S/T	5 FT	056151
			FC	3/8 X 1/2 SAE ANG	5 FT	054909
		1-1/2	FC	3/8 X 1/2 ODF ANG	5 FT	055994
			FC	3/8 X 1/2 SAE ANG	5 FT	054917
		2	FC	3/8 X 1/2 ODF S/T	5 FT	053266
			FC	3/8 X 1/2 SAE ANG	5 FT	053069
3-1/2	FC	3/8 X 1/2 SAE ANG	5 FT	054138		
R-134a R-12	HFE HFES	1/4	MC	3/8 X 1/2 SAE ANG	30 IN	057860
		1/2	MC	3/8 X 1/2 ODF S/T	5 FT	065645
			MC	3/8 X 1/2 SAE ANG	5 FT	057616
		3/4	MC	3/8 X 1/2 ODF ANG	5 FT	057784
			MC	3/8 X 1/2 ODF S/T	5 FT	059422
		1	MC	3/8 X 1/2 ODF ANG	5 FT	058546
			MC	3/8 X 1/2 ODF S/T	5 FT	065646
			MC	3/8 X 1/2 SAE ANG	5 FT	057617
		1-1/2	MC	3/8 X 1/2 SAE ANG	5 FT	057895
			MC	3/8 X 1/2 ODF S/T	5 FT	065647
		1-3/4	MC	3/8 X 1/2 SAE	5 FT	058152
			MC	3/8 X 1/2 SAE ANG	5 FT	057896
		4	MC	3/8 X 1/2 SAE ANG	5 FT	057897
			MC	5/8 X 7/8 ODF S/T	5 FT	057903
11	MC	5/8 X 7/8 ODF S/T	5 FT	057906		
	MC	7/8 X 1 1/8 ODF S/T	5 FT	058681		
14	MC	7/8 X 1 3/8 ODF S/T	5 FT	064000		
R-22 R-407C	HFE HFES	1/4	HC	3/8 X 1/2 ODF S/T	5 FT	055927
			HC	3/8 X 1/2 SAE	5 FT	054924
			HZ	3/8 X 1/2 SAE	5 FT	054925
		1/2	HC	1/4 X 1/2 SAE ANG	5 FT	059079
			HC	3/8 X 1/2 ODF ANG	5 FT	054838
			HC	3/8 X 1/2 ODF S/T	5 FT	055827
			HC	3/8 X 1/2 SAE	5 FT	054361
			HZ	3/8 X 1/2 ODF S/T	5 FT	055889
			HZ	3/8 X 1/2 SAE	5 FT	054365
		1	HC	3/8 X 1/2 ODF ANG	5 FT	055494
			HC	3/8 X 1/2 ODF S/T	5 FT	055708
			HC	3/8 X 1/2 SAE	5 FT	054930
			HW 35	3/8 X 1/2 SAE	5 FT	054932
		1-1/2	HZ	3/8 X 1/2 SAE	5 FT	054931
			HC	3/8 X 1/2 ODF ANG	5 FT	055495
			HC	3/8 X 1/2 ODF S/T	5 FT	055863
			HC	3/8 X 1/2 SAE	5 FT	054936
			HZ	3/8 X 1/2 ODF S/T	5 FT	055870
		2	HZ	3/8 X 1/2 SAE	5 FT	054937
			HC	3/8 X 1/2 ODF S/T	5 FT	055706
			HC	3/8 X 1/2 SAE	5 FT	054942
			HC	3/8 X 1/2 ODF ANG	5 FT	054946
		2-1/2	HZ	3/8 X 1/2 SAE	5 FT	054943
			HC	3/8 X 1/2 ODF ANG	5 FT	056042
			HC	3/8 X 1/2 ODF S/T	5 FT	055931
		3	HC	3/8 X 1/2 SAE	5 FT	054950
			HC	3/8 X 1/2 ODF ANG	5 FT	054756
			HC	3/8 X 1/2 ODF S/T	5 FT	053916
			HC	3/8 X 1/2 SAE	5 FT	053317
			HC	1/2 X 5/8 ODF ANG	5 FT	064761
HCA	3/8 X 1/2 ODF S/T		5 FT	058648		
HCA	1/2 X 5/8 ODF S/T		5 FT	061730		
HZ	3/8 X 1/2 ODF S/T		5 FT	055924		
HZ	3/8 X 1/2 SAE	5 FT	053191			

HF/HFK Series

Ordering Information (continued)

HF Series – Externally Equalized (continued)							
Refrigerant	Series	Tons*	Charge	Connections	Cap Tube	PCN	
R-22 R-407C	HFE HFES	5-1/2	HC	3/8 X 1/2 ODF S/T	5 FT	054141	
			HC	3/8 X 1/2 SAE	5 FT	054140	
			HC	1/2 X 5/8 ODF ANG	5 FT	054778	
			HC	1/2 X 7/8 ODF S/T	5 FT	055187	
			HC	5/8 X 7/8 ODF S/T	5 FT	054779	
			HCA	3/8 X 1/2 ODF S/T	5 FT	065649	
			HCA	1/2 X 5/8 ODF ANG	5 FT	057378	
			HZ	3/8 X 1/2 ODF S/T	5 FT	054780	
		8	HZ	3/8 X 1/2 SAE	5 FT	054777	
			HC	1/2 X 5/8 ODF S/T	5 FT	057312	
			HC	5/8 X 1 1/8 ODF ST	5 FT	057313	
			HCA	1/2 X 7/8 ODF S/T	5 FT	056818	
			HCA	5/8 X 1 1/8 ODF ST	5 FT	056819	
			HC	1/2 X 5/8 ODF S/T	5 FT	057315	
			HC	5/8 X 7/8 ODF S/T	5 FT	057256	
			HC	7/8 X 1 1/8 ODF S/T	5 FT	057316	
		10	HCA	5/8 X 7/8 ODF S/T	5 FT	056820	
			HCA	5/8 X 1 1/8 ODF S/T	5 FT	056821	
			HC	5/8 X 1 1/8 ODF S/T	5 FT	062737	
			12	HC	5/8 X 7/8 ODF S/T	5 FT	057317
		HC		7/8 X 1 1/8 ODF S/T	5 FT	057318	
		HCA		5/8 X 1 1/8 ODF S/T	5 FT	056824	
		HCA		5/8 X 7/8 ODF S/T	5 FT	056823	
		HCA		7/8 X 1 1/8 ODF S/T	5 FT	056825	
		15	HC	7/8 X 1 1/8 ODF S/T	5 FT	062055	
			HCA	7/8 X 1 1/8 ODF S/T	5 FT	058490	
			20	SC	1/4 x 1/2 ODF S/T	30 IN	066533
				SW 45	3/8 X 1/2 ODF S/T	5 FT	065734
1/4	SW 45	3/8 X 1/2 SAE ANG	5 FT	066623			
	SZ	3/8 X 1/2 ODF S/T	5 FT	065733			
	SC	3/8 X 1/2 ODF ANG	5 FT	058975			
1/2	SW 45	3/8 X 1/2 ODF S/T	5 FT	065736			
	SW 45	3/8 X 1/2 SAE ANG	5 FT	066040			
	SZ	3/8 X 1/2 ODF ANG	5 FT	058995			
	SZ	3/8 X 1/2 ODF S/T	5 FT	065735			
	SC	3/8 X 1/2 ODF S/T	5 FT	065650			
1	SC	3/8 X 1/2 ODF ANG	5 FT	058976			
	SW 45	3/8 X 1/2 ODF ANG	5 FT	059086			
	SW 45	3/8 X 1/2 SAE ANG	5 FT	066624			
	SW 45	3/8 X 1/2 ODF S/T	5 FT	065651			
	SZ	3/8 X 1/2 ODF S/T	5 FT	064289			
1-1/4	SC	3/8 X 1/2 ODF ANG	5 FT	058977			
	SW 45	3/8 X 1/2 ODF S/T	5 FT	057976			
	SZ	3/8 X 1/2 ODF S/T	5 FT	065737			
1-1/2	SC	3/8 X 1/2 ODF S/T	5 FT	057974			
	SW 45	3/8 X 1/2 ODF S/T	5 FT	065738			
	SW 45	3/8 X 1/2 SAE ANG	5 FT	066625			
	SZ	3/8 X 1/2 ODF S/T	5 FT	064290			
	SC	3/8 X 1/2 ODF S/T	5 FT	057958			
2	SW 45	3/8 X 1/2 ODF S/T	5 FT	065740			
	SW 45	3/8 X 1/2 SAE ANG	5 FT	066627			
	SZ	3/8 X 1/2 ODF S/T	5 FT	065739			
	SC	3/8 X 1/2 ODF S/T	5 FT	065652			
3-1/2	SC	5/8 X 7/8 ODF S/T	5 FT	062151			
	SW 45	1/2 X 5/8 ODF S/T	5 FT	066534			
	SZ	1/2 X 5/8 ODF S/T	5 FT	061694			
5	SC	5/8 X 7/8 ODF S/T	5 FT	066535			
	SW 45	5/8 X 7/8 ODF S/T	5 FT	064170			
	SZ	5/8 X 7/8 ODF S/T	5 FT	058451			
7	SC	5/8 X 7/8 ODF S/T	5 FT	066536			
	SW45	5/8 X 7/8 ODF S/T	5 FT	066537			
	SZ	5/8 X 7/8 ODF S/T	5 FT	064291			
10	SC	5/8 X 7/8 ODF S/T	5 FT	066538			
	SW 45	5/8 X 7/8 ODF S/T	5 FT	064195			
	SZ	5/8 X 7/8 ODF S/T	5 FT	062828			

Standard Product Offering

Thermal Expansion Valves
 TXV Extended Capacity Tables
 EX Valves and Controls
 Solenoid Valves and Coils
 Solenoid Capacity Tables
 Industrial Solenoid Valves
 Shut Off Valves
 System Protectors
 System Protectors Capacity Tables
 Oil Controls
 Temperature Pressure Controls

HF/HFK Series

Ordering Information (continued)

HF Series – Externally Equalized (continued)						
Refrigerant	Series	Tons*	Charge	Connections	Cap Tube	PCN
R-502	HFE HFES	1/4	RC	3/8 X 1/2 SAE	5 FT	054366
			RC	3/8 X 1/2 ODF ANG	5 FT	055092
			RZ	3/8 X 1/2 ODF ANG	5 FT	055491
			RZ	3/8 X 1/2 SAE	5 FT	054370
		1/2	RC	3/8 X 1/2 ODF ANG	5 FT	055992
			RC	3/8 X 1/2 ODF S/T	5 FT	056022
			RC	3/8 X 1/2 SAE	5 FT	054967
			RW 45	3/8 X 1/2 ODF ANG	5 FT	055996
			RW 45	3/8 X 1/2 SAE	5 FT	054969
			RZ	3/8 X 1/2 ODF ANG	5 FT	055497
			RZ	3/8 X 1/2 ODF S/T	5 FT	056024
			RZ	3/8 X 1/2 SAE	5 FT	054968
R-502	HFE HFES	1	RC	3/8 X 1/2 ODF ANG	5 FT	054983
			RC	3/8 X 1/2 ODF S/T	5 FT	056029
			RC	3/8 X 1/2 SAE	5 FT	054979
			RW 45	3/8 X 1/2 SAE	5 FT	054981
			RZ	3/8 X 1/2 ODF ANG	5 FT	055496
			RZ	3/8 X 1/2 ODF S/T	5 FT	056225
			RZ	3/8 X 1/2 SAE	5 FT	054980
			1-1/2	RC	3/8 X 1/2 ODF ANG	5 FT
		RC		3/8 X 1/2 ODF S/T	5 FT	056031
		RC		3/8 X 1/2 SAE	5 FT	054988
		RW 45		3/8 X 1/2 ODF ANG	5 FT	055991
		RW 45		3/8 X 1/2 ODF S/T	5 FT	056032
		RW 45		3/8 X 1/2 SAE	5 FT	054990
		RZ		3/8 X 1/2 ODF ANG	5 FT	055498
		RZ		3/8 X 1/2 SAE	5 FT	054989
		2	RC	3/8 X 1/2 ODF ANG	5 FT	054768
			RC	3/8 X 1/2 ODF S/T	5 FT	053270
			RC	3/8 X 1/2 SAE	5 FT	053070
			RW 45	3/8 X 1/2 SAE	5 FT	054992
			RZ	3/8 X 1/2 ODF S/T	5 FT	053271
			RZ	3/8 X 1/2 ODF ANG	5 FT	054844
			RZ	3/8 X 1/2 SAE	5 FT	053071
			3-1/2	RC	3/8 X 1/2 ODF ANG	5 FT
		RC		3/8 X 1/2 ODF S/T	5 FT	054143
		RC		3/8 X 1/2 SAE	5 FT	054142
		RW 45		3/8 X 1/2 ODF ANG	5 FT	058907
		RZ		3/8 X 1/2 ODF ANG	5 FT	054785
		RZ		3/8 X 1/2 ODF S/T	5 FT	054784
		RZ		3/8 X 1/2 SAE	5 FT	054145
		5		RC	3/8 X 1/2 ODF S/T	5 FT
			RC	5/8 X 7/8 ODF S/T	5 FT	058608
			RW 45	5/8 X 7/8 ODF S/T	5 FT	058305
			RZ	1/2 X 5/8 ODF ANG	5 FT	061196
		7	RC	5/8 X 7/8 ODF S/T	5 FT	058607
			RW 45	5/8 X 7/8 ODF S/T	5 FT	059291
		10	RC	5/8 X 7/8 ODF S/T	5 FT	058808

* For interchangeable refrigerant charges R-134a/R-12, R-404A/R-507/R-502, and R-22/R-407C, the tons of capacity shown in the table are for the first (primary) refrigerant listed. Consult the Nominal Capacity Table for determining the tons of capacity for the secondary refrigerants listed.

Example: A 1/4 ton R-12 valve is required. What R-134a ton valve should be selected?

Solution: From the Nominal Capacity Table, a 1/2 ton R-134a valve is equivalent to a 1/4 ton R-12 valve.

Standard Product Offering

HF/HFK Series

Ordering Information (continued)

HFESC Series – Externally Equalized (continued)						
Refrigerant	Series	Tons*	Charge	Connections	Cap Tube	PCN
R-12	HFESC	1/2	FC	3/8 X 1/2 ODF ANG	5 FT	057397
		1	FC	3/8 X 1/2 ODF ANG	5 FT	057398
		1-1/2	FC	3/8 X 1/2 ODF ANG	5 FT	057399
R-134a R-12	HFESC	1/4	MC	3/8 X 1/2 ODF ANG	5 FT	057572
		1/2	MC	3/8 X 1/2 ODF ANG	5 FT	058069
		1	MC	3/8 X 1/2 ODF ANG	5 FT	057570
		1-1/2	MC	3/8 X 1/2 ODF ANG	5 FT	057568
		2-1/2	MC	3/8 X 1/2 ODF ANG	5 FT	058421
R-22 R-407C	HFESC	1/4	HC	3/8 X 1/2 ODF ANG	5 FT	057409
			HZ	3/8 X 1/2 ODF ANG	5 FT	057428
		1/2	HC	3/8 X 1/2 ODF ANG	5 FT	057291
			HZ	3/8 X 1/2 ODF ANG	5 FT	057429
		1	HC	3/8 X 1/2 ODF ANG	5 FT	057410
			HZ	3/8 X 1/2 ODF ANG	5 FT	057430
		1-1/2	HC	3/8 X 1/2 ODF ANG	5 FT	057292
			HZ	3/8 X 1/2 ODF ANG	5 FT	057321
		2	HZ	3/8 X 1/2 ODF ANG	5 FT	057433
			HC	3/8 X 1/2 ODF ANG	5 FT	057294
		2-1/2	HC	3/8 X 1/2 ODF ANG	5 FT	057411
			HZ	3/8 X 1/2 ODF ANG	5 FT	057434
		3	HC	3/8 X 1/2 ODF ANG	5 FT	057412
			HZ	3/8 X 1/2 ODF ANG	5 FT	057748
		5-1/2	HC	3/8 X 1/2 ODF ANG	5 FT	057781
		8	HC	3/8 X 1/2 ODF ANG	5 FT	058609
		1/4	SC	1/4 x 1/2 ODF ANG	30 IN	066539
			SW45	1/4 x 1/2 ODF ANG	30 IN	066540
			SZ	1/4 x 1/2 ODF ANG	30 IN	066542
		1/2	SC	1/4 x 1/2 ODF ANG	30 IN	066543
			SW45	1/4 x 1/2 ODF ANG	30 IN	066544
			SZ	1/4 x 1/2 ODF ANG	30 IN	066545
		1	SC	3/8 x 1/2 ODF ANG	5 FT	058135
			SW45	3/8 x 1/2 ODF ANG	5 FT	058157
			SZ	3/8 x 1/2 ODF ANG	5 FT	058118
		1-1/2	SC	3/8 x 1/2 ODF ANG	5 FT	058119
			SW45	3/8 x 1/2 ODF ANG	5 FT	058136
			SZ	3/8 x 1/2 ODF ANG	5 FT	058121
		2	SC	3/8 x 1/2 ODF ANG	5 FT	058122
			SW45	3/8 x 1/2 ODF ANG	5 FT	058212
			SZ	3/8 x 1/2 ODF ANG	5 FT	058214
		3-1/2	SC	3/8 x 1/2 ODF ANG	5 FT	058071
			SW45	3/8 x 1/2 ODF ANG	5 FT	066547
			SZ	3/8 x 1/2 ODF ANG	5 FT	066548
		5	SC	3/8 x 1/2 ODF ANG	5 FT	058220
			SW45	3/8 x 1/2 ODF ANG	5 FT	058221
			SZ	3/8 x 1/2 ODF ANG	5 FT	066549
		7	SC	5/8 x 7/8 ODF ANG	5 FT	065458
			SW45	5/8 x 7/8 ODF ANG	5 FT	066550
			SZ	5/8 x 7/8 ODF ANG	5 FT	064058
		10	SC	5/8 x 7/8 ODF ANG	5 FT	064219
			SW45	5/8 x 7/8 ODF ANG	5 FT	066551
SZ	5/8 x 7/8 ODF ANG		5 FT	064059		
R-404A R-507 R-502	HFESC	1/4	RC	3/8 X 1/2 ODF ANG	5 FT	057436
			RZ	3/8 X 1/2 ODF ANG	5 FT	057454
		1/2	RC	3/8 X 1/2 ODF ANG	5 FT	057437
			RZ	3/8 X 1/2 ODF ANG	5 FT	057455
		1	RC	3/8 X 1/2 ODF ANG	5 FT	057438
			RW 45	3/8 X 1/2 ODF ANG	5 FT	057446
			RZ	3/8 X 1/2 ODF ANG	5 FT	057456
		1-1/2	RC	3/8 X 1/2 ODF ANG	5 FT	057439
			RW 45	3/8 X 1/2 ODF ANG	5 FT	057448
			RZ	3/8 X 1/2 ODF ANG	5 FT	057322
		2	RC	3/8 X 1/2 ODF ANG	5 FT	057440
			RZ	3/8 X 1/2 ODF ANG	5 FT	057457
		2-1/2	RC	3/8 X 1/2 ODF ANG	5 FT	057441
			RZ	3/8 X 1/2 ODF ANG	5 FT	057458
		5	RC	3/8 X 1/2 ODF ANG	5 FT	058595
RZ	3/8 X 1/2 ODF ANG		5 FT	059654		

HF/HFK Series

Ordering Information (continued)

HFSC Internal Equalized						
Refrigerant	Series	Tons*	Charge	Connections	Cap Tube	PCN
R-134a R-12	HFSC	1/4	MC	3/8 X 1/2 ODF ANG	5 FT	057573
		1/2	MC	3/8 X 1/2 ODF ANG	5 FT	058067
R-22 R-407C	HFSC	1/4	HC	3/8 X 1/2 ODF ANG	5 FT	057467
		1/2	HC	3/8 X 1/2 ODF ANG	5 FT	057293
			HZ	3/8 X 1/2 ODF ANG	5 FT	057482
		1	HC	3/8 X 1/2 ODF ANG	5 FT	057468
		2	HC	3/8 X 1/2 ODF ANG	5 FT	057470
R-404A R-507 R-502	HFSC	1/8	SC	3/8 X 1/2 ODF ANG	5 FT	058248
			SW45	1/4 X 1/2 ODF ANG	30 IN	066552
			SZ	1/4 X 1/2 ODF ANG	30 IN	066553
		1/4	SC	3/8 X 1/2 ODF ANG	5 FT	058249
			SW45	1/4 X 1/2 ODF ANG	30 IN	066554
			SZ	1/4 X 1/2 ODF ANG	30 IN	066555
		1/2	SC	3/8 X 1/2 ODF ANG	5 FT	058250
			SW45	1/4 X 1/2 ODF ANG	30 IN	066556
			SZ	1/4 X 1/2 ODF ANG	30 IN	066557
		1	SC	3/8 X 1/2 ODF ANG	5 FT	058251
			SW45	3/8 X 1/2 ODF ANG	5 FT	066558
			SZ	3/8 X 1/2 ODF ANG	5 FT	066559
1-1/4	SC	3/8 X 1/2 ODF ANG	5 FT	058252		
	SW45	3/8 X 1/2 ODF ANG	5 FT	066560		
	SZ	3/8 X 1/2 ODF ANG	5 FT	066561		
R-502	HFSC	1/4	RC	3/8 X 1/2 ODF ANG	5 FT	057487
			RZ	3/8 X 1/2 ODF ANG	5 FT	057484
		1/2	RC	3/8 X 1/2 ODF ANG	5 FT	057488
			RZ	3/8 X 1/2 ODF ANG	5 FT	057485
		1	RC	3/8 X 1/2 ODF ANG	5 FT	057489
			RZ	3/8 X 1/2 ODF ANG	5 FT	057486

* For interchangeable refrigerant charges R-134a/R-12, R-404A/R-507/R-502, and R-22/R-407C, the tons of capacity shown in the table are for the first (primary) refrigerant listed. Consult the Nominal Capacity Table for determining the tons of capacity for the secondary refrigerants listed.

Example: A 1/4 ton R-12 valve is required. What R-134a ton valve should be selected? **Solution:** From the Nominal Capacity Table, a 1/2 ton R-134a valve is equivalent to a 1/4 ton R-12 valve.

Standard Product Offering

Thermal Expansion Valves
TXV Extended Capacity Tables
EX Valves and Controls
Solenoid Valves and Coils
Solenoid Capacity Tables
Industrial Solenoid Valves
Shut Off Valves
System Protectors
System Protectors Capacity Tables
Oil Controls
Temperature Pressure Controls

TRAE+ Series

The TRAE Plus series is a large capacity valve designed for refrigeration, air conditioning, heat pump, and chiller applications.

Features

- Stainless steel power element eliminates corrosion and prevents valve failure
- Suitable for Bi-Flow applications
- Replaceable power element and cage assembly for full serviceability
- Double balanced port design improves operation and stability over wide loads and evaporator temperature ranges
- Square body with straight-thru connections
- Solid copper connections
- External superheat adjustment
- Large diaphragm provides superior stability
- Permanent inlet strainer



Options

- Cages (For available cage kits, see page 26.)

Specifications

- Maximum working pressure: 450 psig
- Torque Power Assembly: 375 - 425 in. lb.
- UR/CUR file number: SA 5312

Nomenclature example: TRAE+ 30 HC 10 FT 7/8 x 1/8 ODF S/T

TRA	E	+	30	H	C	10 FT	7/8 x 1/8	ODF	S/T
Valve Series Double Balanced Port Design	Equalizer E=External 1/4"SAE	Replaceable Components Cage and Power Assembly	Capacity Nominal Rating in Tons (See nominal capacity table below)	Refrigerant Code +F = R-12 • H = R-22 +M = R-134a • N = R-407C *P = R-507 *R = R-502 *S = R-404A	Charge Code C = medium temp CA = heat pump W(MOP) = press. limiting Z = low temp	Capillary Tube Length 10 FT (std)	Inlet x Outlet Connection Sizes 5/8 x 7/8 7/8 x 1 1/8 1 1/8 x 1 3/8	Connection Type ODF = solder (Only)	Configuration S/T = straight-thru (Only)

- + = R-12 and R-134a are interchangeable refrigerant charges
- * = R-507, R-502 and R-404A are interchangeable refrigerant charges
- = R-22 and R-407C are interchangeable refrigerant charges

TRAE+ Series – Nominal* Capacity Table in Tons (kW)

R-12	R-134a	R-22/R-407C	R-507/R-404A/ R-502
7½ (27)	9 (32)	10 (35)	8 (28)
10 (35)	13 (46)	15 (53)	12 (42)
12 (42)	14 (50)	20 (71)	14 (50)
18 (64)	22 (78)	30 (106)	20 (71)
25 (88)	30 (106)	40 (142)	30 (106)

All capacities shown are at 100°F condensing, 40°F evaporator temperature.
*See Extended Capacity Tables for ratings at a wide range of conditions per ARI standard 750.

TRAE+ Dimensional Data (in)

TRAE Valve Type	Nominal Inlet (B)	Sizes (ODF) Outlet (E)	Inlet		Inlet	
			A	C	D	F
TRAE+ 10-40 Tons	5/8	7/8	1.57	0.50	2.09	0.75
	5/8	1-1/8	1.57	0.50	2.21	0.91
	7/8	7/8	2.09	0.75	2.09	0.75
	7/8	1-3/8	2.09	0.75	2.21	0.91
	7/8	1-3/8	2.09	0.75	2.39	0.97
	1-1/8	1-1/8	2.21	0.91	2.21	0.97
1-1/8	1-3/8	2.21	0.91	2.39	0.97	

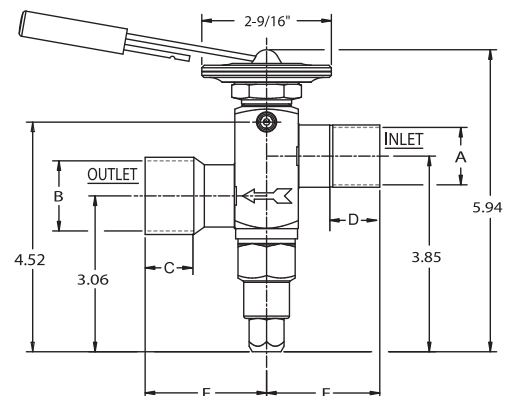

TRAE Series

The TRAE series is a large capacity valve for chiller, heat pump, refrigeration, and air conditioning applications.

Features

- Suitable for Bi-Flow applications
- External superheat adjustment
- Integral body with straight-thru connections
- Balanced port design improves valve operation and stability over wide loads and evaporator temperature range
- Solid copper connections
- Large diaphragm provides superior stability

Specifications

- Maximum Working Pressure: 450 psig
- UR/CUR file number: SA 5312

Nomenclature example: TRAE 50 HC 10 FT 7/8 x 1/8 ODF S/T

TRA	E	50	H	C	10 FT	7/8 x 1/8	ODF	S/T
Valve Series Hermetic Balanced Port Design	Equalizer E=External 1/4"SAE	Capacity Nominal Rating in Tons (See nominal capacity table below)	Refrigerant Code +F = R-12 • H = R-22 +M = R-134a • N = R-407C *P = R-507 *R = R-502 *S = R-404A	Charge Code C = medium temp CA = heat pump W(MOP) = press. limiting Z = low temp	Capillary Tube Length 10 FT (std)	Inlet x Outlet Connection Sizes 1/4 x 3/8 3/8 x 1/2	Connection Type ODF = solder (Only)	Configuration S/T = straight-thru (Only)

+ = R-12 and R-134a are interchangeable refrigerant charges

* = R-507, R-502 and R-404A are interchangeable refrigerant charges

• = R-22 and R-407C are interchangeable refrigerant charges

TRAE Series – Nominal* Capacity Table in Tons (kW)

R-12	R-134a	R-22/R-407C	R-507/R-404A/R-502
30 (106)	40 (142)	50 (177)	35 (124)
35 (124)	45 (159)	60 (212)	40 (142)
40 (142)	50 (177)	70 (248)	50 (177)

All capacities shown are at 100°F condensing, 40°F evaporator temperature.

*See Extended Capacity Tables for ratings at a wide range of conditions per ARI standard 750.

Dimensional Data (in)

Remote Bulb Tubing Length 10' Standard

Connection Size		A	B	C MIN	D MIN	E	F
Inlet	Outlet						
7/8 ODF	7/8 ODF	0.88	0.88	0.75	0.75	2.09	2.09
7/8 ODF	1-1/8 ODF	0.88	1.13	0.75	0.91	2.90	2.21
7/8 ODF	1-3/8 ODF	0.88	1.38	0.75	0.97	2.90	2.39
1-1/8 ODF	1-1/8 ODF	1.13	1.13	0.91	0.91	2.21	2.21
1-1/8 ODF	1-3/8 ODF	1.13	1.38	0.91	0.97	2.21	2.39
1-3/8 ODF	1-3/8 ODF	1.38	1.38	0.91	0.97	2.39	2.39

Remote Bulb Table

Remote Bulb Tubing Length	Bulb Length
5, 10, 15 ft.	4-7/8
20, 30 ft.	
40, 50 ft.	6-3/16

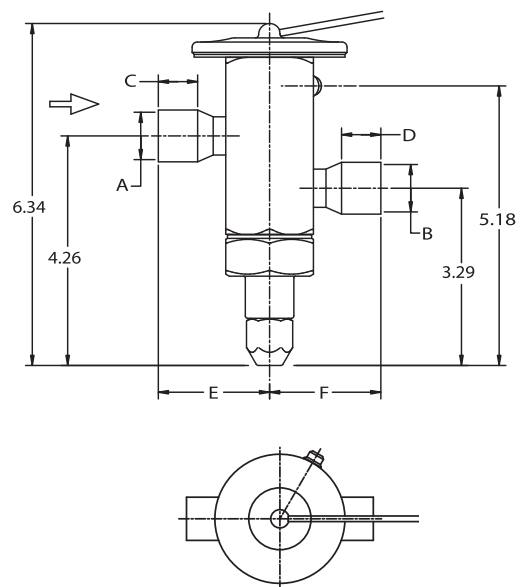

TRAE/TRAE+ Series

Ordering Information

Refrigerant	Series	Tons*	Charge	Connections	Cap Tube	PCN
R-22 R-407C R-404A R-134A	TRAE+	10	HC	5/8 X 7/8 ODF S/T	5 FT	062718
			HCA	5/8 X 7/8 ODF S/T	10 FT	063138
			HCA	7/8 X 1-1/8 ODF S/T	10 FT	063554
			HC	7/8 X 1-1/8 ODF S/T	15 FT	063100
		15	HC	7/8 X 1-1/8 ODF S/T	10 FT	062721
			HCA	5/8 X 7/8 ODF S/T	10 FT	063510
			HCA	7/8 X 1-1/8 ODF S/T	10 FT	062722
			HCA	7/8 X 1-3/8 ODF S/T	10 FT	063141
			HW100	5/8 X 7/8 ODF S/T	10 FT	063103
			HC	7/8 X 1-3/8 ODF S/T	10 FT	063650
			HCA	7/8 X 1-1/8 ODF S/T	10 FT	062725
		20	HCA	1 1/8 X 1-1/8 ODF S/T	10 FT	064581
			HW90	7/8 X 1-1/8 ODF S/T	15 FT	064018
			HC	7/8 X 1-1/8 ODF S/T	10 FT	062724
			SC	7/8 X 1-1/8 ODF S/T	10 FT	063461
			SZ	5/8 X 7/8 ODF S/T	10 FT	064923
			HC	7/8 X 1-1/8 ODF S/T	10 FT	062727
			HC	1-1/8 X 1-3/8 ODF S/T	10 FT	062728
		30	HCA	1-1/8 X 1-3/8 ODF S/T	10 FT	062730
			HW100	7/8 X 1-3/8 ODF S/T	5 FT	063425
			MC	1-1/8 X 1-3/8 ODF S/T	10 FT	064001
			HC	1-1/8 X 1-3/8 ODF S/T	10 FT	062733
			HC	1-1/8 X 1-3/8 ODF S/T	15 FT	063153
			HCA	1-1/8 X 1-3/8 ODF S/T	10 FT	062734
			SC	1-1/8 X 1-3/8 ODF S/T	10 FT	064217
		40	MC	1-1/8 X 1-3/8 ODF S/T	15 FT	063941
			SC	1-1/8 X 1-3/8 ODF S/T	10 FT	064217
			MC	1-1/8 X 1-3/8 ODF S/T	10 FT	063941
	MC		1-1/8 X 1-3/8 ODF S/T	10 FT	063941	
	TRAE	35	SC	1-1/8 X 1-3/8 ODF S/T	10 FT	064217
		40	MC	1-1/8 X 1-3/8 ODF S/T	10 FT	063941
		50	HC	1-1/8 X 1-3/8 ODF S/T	10 FT	061700
60		HC	1-1/8 X 1-3/8 ODF S/T	10 FT	061865	
70		HC	1-1/8 X 1-3/8 ODF S/T	10 FT	061866	

(+) Replaceable Power Assembly

Standard Product Offering

Cage Replacement Kits for TRAE+ Series Valves

Cage kits are cross referenced by capacity and tonnage in the table below. Each cage kit consists of a replacement cage and cage removal wrench. In addition, the cage removal wrench (KT-20294) can be ordered as a separate item.

PCN	TRAE+ KIT	Nominal Capacity - Tons		
		R-22	R-12/R-134a	R-507/R-404A/ R-502
063387	KT-20289 CAGE KIT	10	9	8
063388	KT-20290 CAGE KIT	15	13	12
063389	KT-20291 CAGE KIT	20	14	14
063390	KT-20292 CAGE KIT	30	22	20
063391	KT-20293 CAGE KIT	40	30	30
063392	KT-20294 CAGE WRENCH KIT	All tonnages		

Standard Product Offering

Replacement Parts

Description	Part Number	PCN
Power Assembly	X-28458 HCA-2	063414
	X-28458 MC	063593
	X-28458 SC	095439
	X-28458 HW100-2	063416
	X-28458 SW45-2	065298
Seal Nut	27676-1	058707

Standard Product Offering

T-Series – Take-Apart

The T-series Take-Apart valves, with adjustable superheat and replaceable, interchangeable components are ideal for original equipment and field replacements in air conditioning, heat pump, and refrigeration applications.

Features

- Take-Apart construction for easy field service
- External superheat adjustment
- Bi-Flow capability
- Stainless steel power assembly up to 18 tons

Options

- Interchangeable, replaceable cages
- Interchangeable body flanges
- Interchangeable power assemblies
- 1/4 to 100 tons capacity



Specifications

- Maximum working pressure: 450 psig
- Torque Bolts: 300 in. lb.

Nomenclature example: TCLEB 5 HC 5 FT 3/8 x 1/2 SAE ANG

TCL	E	B	5	H	C	5 FT	3/8 x 1/2	SAE	ANG
Valve Series Take-Apart Adjustable	Equalizer E=External (Omit for Internal)	Bleed Hole (optional) B=Bleed Hole (Omit for no bleed hole)	Capacity Nominal Rating in Tons (See Cage Assembly Interchangeability Tables)	Refrigerant Code +F = R-12 • H = R-22 +M = R-134a • N = R-407C *P = R-507 *R = R-502 *S = R404A	Charge Code C = medium temp CA = heat pump W(MOP) = press. limiting Z = low temp	Capillary Tube Length	Inlet x Outlet Connection Sizes Various sizes are available (valve is also available less flange)	Connection Type SAE=flare ODF=solder	Configuration ANG = 90° angle S/T=straight-thru

- + = R-12 and R-134a are interchangeable refrigerant charges
- * = R-507, R-502 and R-404A are interchangeable refrigerant charges
- = R-22 and R-407C are interchangeable refrigerant charges

Single Outlet "T" Series Body Flanges with Bleed Hole for Use with PSC Compressors

Valve Type			Bleed Hole Diameter ¹ for % Capacity Bypass											
R-12/R-134a	R-22/R-407C	R-507/R-502/R-404A	10%		15%		20%		25%		30%		40%	
			Dia. (In)	Drill Size	Dia. (In)	Drill Size	Dia. (In)	Drill Size	Dia. (In)	Drill Size	Dia. (In)	Drill Size	Dia. (In)	Drill Size
TCL1/4F	TCL1/2H	TCL1/2R	-	-	0.02	1/64	0.02	77	0.02	76	0.02	74	0.03	72
TCL1/2F	TCL1H	TCL1/2R	0.02	77	0.02	75	0.02	73	0.03	71	0.03	69	0.04	65
TCL1F	TCL2H	TCL1R	0.03	71	0.03	1/32	0.04	64	0.04	60	0.05	56	0.05	55
TCL2F	TCL3H	TCL2R	0.03	70	0.04	65	0.04	60	0.04	57	0.05	3/4	0.06	54
TCL3F	TCL5H	TCL3R	0.04	65	0.04	57	0.05	55	0.06	54	0.06	1/16	0.07	50
TCL4F	TCL7-1/2H	TCL4-1/2R	0.04	57	0.05	55	0.06	53	0.07	51	0.08	48	0.09	44
TCL6-1/2F	TCL10H	TCL7R	0.05	55	0.06	53	0.07	50	0.08	47	0.09	44	0.10	39
TCL7-1/2F	TCL12H	TCL8R	0.05	55	0.06	53	0.07	50	0.08	47	0.09	44	0.10	39

¹Bleed hole sizes shown above are based on a percent of full effective port area of the valve. This does not necessarily indicate the percent of valve capacity that will be bypassed. The hole sizes shown above should be used for reference only. Normal industry practice is to equalize systems 3 to 5 minutes.

T-Series – Take-Apart

Small Capacity ½ to 18 tons (R-22 Nominal – Bi Flow)

Step 1: Select Cage from Capacity Table

Externally Adjustable
Cage Assembly



Superheat Plug
X28124-1 (ODM)
(PCN: 058336)

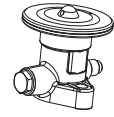

Step 3: Select Power Assembly

Capscrews



Valve Type	Nominal Capacity - Tons						Cage Assembly ¹	
	R-12	R-134a	R-22	R-404A R-507	R-502	R-407C	Description	PCN
TCL TCLE	1/4	1/4	1/2	1/4	1/4	1/2	X22440B1A	037034
	1/4	1/4	1/2	1/4	1/4	1/2	X22440B1B	037035
	1/2	3/4	1	1/2	1/2	1	X22440B2A	037036
	1/2	3/4	1	1/2	1/2	1	X22440B2B	037037
	1	1-1/2	2	1	1	2	X22440B3A	037038
	1	1-1/2	2	1	1	2	X22440B3B	037039
	2	2-1/2	3	2	2	3	X22440B4A	037040
	2	2-1/2	3	2	2	3	X22440B4B	037041
	3	3-1/2	5	3	3	5	X22440B5B	037043
	4	5-1/2	7-1/2	4-1/2	4-1/2	7-1/2	X22440B6B	037045
	6-1/2	7-1/2	10	7	7	10	X22440B7B	037047
	7-1/2	9	12	8	8	12	X22440B8B	037049
TJLE	7	9	11	7	7	11	XC724B4B	093343
	8	11	14	9	9	14	XC724B5B	038699
TJR	8	11	14	9	9	14	X11873B4B	088837
	11	13	18	12	12	18	X11873B5B	089058

¹ Gaskets included on cage.
Gasket strip X13455-1 (PCN: 027579) replaces all older T-Series Gasket kits.

Standard Product Offering

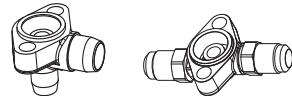

Step 2: Select Flange

Angle, ODF

Straight-Thru, SAE

Valve Type	Flow	Size & Style Connections		Body Flange Part			
		Inlet	Outlet	Number	PCN		
TCL TCLE	Angle	3/8 SAE	1/2 SAE	C500-4	056932		
		3/8 SAE	5/8 SAE	C500-5	057153		
		1/2 SAE	5/8 SAE	C500-6	056294		
		3/8 ODF	1/2 ODF	C501-4	065527		
		3/8 ODF	5/8 ODF	C501-5	065748		
		1/2 ODF	5/8 ODF	C501-7	065861		
		5/8 ODF or 7/8 ODM	7/8 ODF or 1-1/8 ODM	A576	027764		
		Straight- Thru	3/8 SAE	1/2 SAE	X6669-4	051176	
			3/8 SAE	5/8 SAE	X6669-1	050563	
			1/2 SAE	1/2 SAE	X6669-5	083378	
			1/2 SAE	5/8 SAE	X6669-2	050842	
			3/8 ODF	1/2 ODF	9761-5	027769	
	3/8 ODF		5/8 ODF	9761-3	027771		
	1/2 ODF		1/2 ODF	9761-6	027766		
	1/2 ODF		5/8 ODF	9761-4	027268		
	1/2 ODF		7/8 ODF	9761-2	027770		
	5/8 ODF		5/8 ODF	X6346-16	044733		
	5/8 ODF		7/8 ODF	X6346-17	044846		
	5/8 ODF		1-1/8 ODF	X6346-18	094038		
	7/8 ODF	1-1/8 ODF	X6346-34	071757			
	TJLE	Angle	5/8 ODF or 7/8 ODM	7/8 ODF or 1-1/8 ODM	B504	044984	
			5/8 ODF	1-1/8 ODF	X6347-2	094289	
		Straight- Thru	7/8 ODF	1-1/8 ODF	X6347-6	057210	
			7/8 ODF	1-3/8 ODF	X6347-7	057323	
TJR ²			Angle	5/8 ODF or 1-1/8 ODM	7/8 ODF or 1-1/8 ODM	10331	029411
			Straight- Thru	7/8 ODF or 1-1/8 ODM	7/8 ODF or 1-1/8 ODM	10332	032988

² TJR is balanced ported. TJR flange includes extended length capscrews.

Refrigerant	Equalizer Type	Cap Tube Length	Application		Power ⁵ Assembly	PCN								
			Temp. Range	MOP ⁴ (psi)										
							TCL-TCLE-TJLE-TJR Power Assemblies ³							
R-12	Internal	5 FT	-20 to +50	NONE	XB-1019FC1A	052951								
						1/4 SAE	5 FT	-20 to +50	NONE	XB-1019FC1B	049881			
											10 FT	-20 to +50	NONE	XB-1019FC2A
	1/4 SAE	10 FT	-20 to +50	NONE	XB-1019FC2B									
						1/4 SAE	15 FT	-20 to +50	NONE	XB-1019FC3B				
											1/4 SAE	5 FT	-50 to +50	35
	1/4 SAE	5 FT	-50 to +50	55	XB-1019FW551B									
						1/4 SAE	10 FT	-50 to +50	55	XB-1019FW552B				
											1/4 SAE	5 FT	-50 to 0	15
	Internal	5 FT	-20 to +50	NONE	XB-1019HC1A									
						1/4 SAE	5 FT	-20 to +50	NONE	XB-1019HC1B				
											1/4 SAE	10 FT	-20 to +50	NONE
	1/4 SAE	5 FT	-20 to +50	NONE	XB-1019HCA1B									
						1/4 SAE	5 FT	-50 to +5	35	XB-1019HW351B				
											1/4 SAE	5 FT	-50 to +20	55
	1/4 SAE	5 FT	-50 to +30	65	XB-1019HW651B									
						1/4 SAE	5 FT	-50 to +50	100	XB-1019HW1001B				
											1/4 SAE	20 FT	-10 to +50	NONE
1/4 SAE	10 FT	-50 to +50	100	XB-1019HW1002B	062658									
					1/4 SAE	5 FT	-50 to +10	NONE	XB-1019HZ1B	040568				
										1/4 SAE	10 FT	-50 to +10	NONE	XB-1019HZ2B
R-407C	1/4 SAE	5 FT	-20 to +50	NONE										
					1/4 SAE	5 FT	-20 to +50	100	XB-1019NW1001B					
R-507	1/4 SAE	5 FT	-20 to +50	NONE						XB-1019PC1B	061949			
					1/4 SAE	5 FT	-50 to 0	40	XB-1019PW401B		064200			
R-134a	1/4 SAE	5 FT	-50 to +10	NONE						XB-1019Z1B	061951			
					1/4 SAE	5 FT	-20 to +50	NONE	XB-1019MC1B		057878			
	1/4 SAE	10 FT	-20 to +50	NONE						XB-1019MC2B	059548			
					1/4 SAE	5 FT	-50 to +50	55	XB-1019MW551B		057370			
	1/4 SAE	5 FT	-50 to +10	NONE						XB-1019MZ1B	061946			
					R-502	1/4 SAE	5 FT	-20 to +50	NONE		XB-1019RC1B	052955		
1/4 SAE	10 FT	-20 to +50	NONE	XB-1019RC2B						054415				
						1/4 SAE	5 FT	-50 to +20	15	XB-1019RW151B	070346			
1/4 SAE	5 FT	-50 to +5	35	XB-1019RW351B							063644			
						1/4 SAE	5 FT	-50 to +5	45	XB-1019RW451B	055881			
1/4 SAE	10 FT	-50 to +5	45	XB-1910RW452B							055704			
					R-404A	1/4 SAE	5 FT	-50 to +25	65	XB-1019RW651B	063114			
1/4 SAE	5 FT	-50 to +10	NONE	XB-1019RZ1B							046474			
						1/4 SAE	10 FT	-50 to +10	NONE	XB-1019RZ2B	047358			
1/4 SAE	5 FT	-20 to +50	NONE	XB-1019SC-1B							059189			
						1/4 SAE	5 FT	-50 to 0	40	XB-1019SW401B	059130			
1/4 SAE	5 FT	-50 to +25	65	XB-1019SW651B							063541			
					Misc.	Internal	5 FT	Liquid Injection	NONE	XB-1019A-1A	037389			
1/4 SAE	5 FT	NONE	XB-1019A-1B	034803										
				1/4 SAE							5 FT	NONE	XB-1019B-1B	032207
														1/4 SAE
					1/4 SAE	5 FT	NONE	XB-1019CW-1B	084768					

³ Capscrews included with Power Assembly

⁴ Maximum Operating Pressure Limit to prevent motor overload

⁵ Power Assembly final character: A=Internally Equalized, B=Externally Equalized

NOTE: Nominal capacities shown here are based on 40°F evaporator temperature and 100°F vapor-free liquid refrigerant entering the valve. R-12 and R-134a rated at 60 PSID. All other refrigerants rated at 100 PSID.

T-Series – Take-Apart

Large Capacity 22 to 100 tons
(R22 Nominal – Balanced Ported and Bi Flow)



Externally Adjustable
Double Ported
Cage Assembly

Step 1: Select Cage from Capacity Table

Valve Type	Nominal Capacity - Tons						Cage Assembly ¹	
	R-12	R-134a	R-22	R-404A R-507	R-502	R-407C	Description	PCN
TER	13	16	22	14	14	22	X9117B6B	077896
	15	19	26	16	16	26	X9117B7B	078117
	20	25	35	21	21	35	X9117B8B	071155
	25	31	45	27	27	45	X9117B9B	029429
TIR	35	45	55	37	37	55	X9166B10B	070738
THR	35	45	55	37	37	55	X9144B10B	071238
	45	55	75	48	48	70	X9144B11B	020846
	55	68	85	60	60	85	X9144B13B	021067
TMR	55	68	100	60	--	100	X9144B14B	065123

¹ Gaskets included on cage.
Gasket strip X13455-1 (PCN: 027579) replaces all older T-Series Gasket kits.

Standard Product Offering

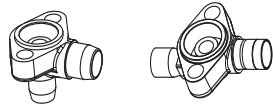

Angle, ODF Straight-Thru, ODF

Step 2: Select Flange

Valve Type	Style	Size & Style Connections		Body Flange Part	
		Inlet	Outlet	Number	PCN
TER ²	ANGLE	7/8 ODF or 1-1/8 ODM	7/8 ODF or 1-1/8 ODM	9153	027919
	STRAIGHT-THRU	7/8 ODF or 1-1/8 ODM	7/8 ODF or 1-1/8 ODM	9152	027918
TIR	ANGLE	7/8 ODF or 1-1/8 ODM	7/8 ODF or 1-1/8 ODM	9151	027926
	STRAIGHT-THRU	7/8 ODF or 1-1/8 ODM	7/8 ODF or 1-1/8 ODM	9150	028849
THR	ANGLE	1-1/8 ODM	1-1/8 ODM	9149	028030
	STRAIGHT-THRU	1-1/8 ODM	1-1/8 ODM	9148	028032
TMR ²	ANGLE	1-1/8 ODM	1-1/8 ODM	9149-1	065124
	STRAIGHT-THRU	1-1/8 ODM	1-1/8 ODM	9148-1	065125

² TER-TMR Flange includes extended length capscrews.

Standard Product Offering

NOTE: Nominal capacities shown here are based on 40°F evaporator temperature and 100°F vapor-free liquid refrigerant entering the valve. R-12 and R-134a rated at 60 PSID. All other refrigerants rated at 100 PSID.

Superheat Plug
X28124-1 (ODM)
(PCN: 058336)

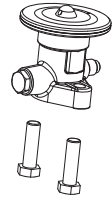

Capscrews

Step 3: Select Power Assembly

Refrigerant	Equalizer Type	Cap Tube Length	TER-TIR-THR-TMR Power Assemblies ³			
			Application		Power Assembly	PCN
			Temp. Range	MOP ⁴ (psi)		
R-12	1/4 SAE	10 FT	-20 to +40	NONE	XC-726FC2B	052957
	1/4 SAE	10 FT	-50 to +50	55	XC-726FW52B	035000
R-22	1/4 SAE	10 FT	-20 to +50	NONE	XC-726HC2B	056421
	1/4 SAE	10 FT	-50 to +50	35	XC-726HW352B	024511
	1/4 SAE	10 FT	-50 to +30	65	XC-726HW652B	025011
	1/4 SAE	10 FT	-20 to +50	NONE	XC-726HCA2B	059333
	1/4 SAE	10 FT	-50 to +50	100	XC-726HW1002B	036750
	1/4 SAE	10 FT	-50 to +10	NONE	XC-726HZ2B	040569
R-134A	1/4 SAE	10 FT	-20 to +50	NONE	XC-726MC2B	057235
	1/4 SAE	10 FT	-50 to +50	55	XC-726MW552B	057372
	1/4 SAE	10 FT	-50 to +10	NONE	XC-726M2B	063075
R-502	1/4 SAE	10 FT	-20 to +50	NONE	XC-726RC2B	052958
	1/4 SAE	10 FT	-50 to +20	15	XC-726RW152B	023351
	1/4 SAE	10 FT	-50 to +50	35	XC-726RW352B	070866
	1/4 SAE	10 FT	-50 to +25	65	XC-726RW652B	071421
R-404A	1/4 SAE	10 FT	-50 to +10	NONE	XC-726RZ2B	046692
	1/4 SAE	10 FT	-20 to +50	NONE	XC-726SC2B	062303
	1/4 SAE	10 FT	-50 to +10	40	XC-726SW402B	063127
	1/4 SAE	10 FT	-50 to +25	65	XC-726SW652B	061692
1/4 SAE	10 FT	-50 to +10	NONE	XC-726SZ2B	063974	

³ Capscrews included with Power Assembly

⁴ Maximum Operating Pressure Limit to prevent motor overload

Standard Product Offering

Additional Parts

Description	PCN
Packing Nut Wrench	039862
Gasket Strip	027579
Superheat Adjustment Plug	058336

Standard Product Offering

T-Series – Take-Apart

Ordering Information Valves less flange – (VLF)

TCLE, TJLE & TJRE SAE External 5 FT. Cap Tube Length

Valve Description					
R-12	PCN	R-22	PCN	R-502	PCN
TCLE 1/2 FC	054413	TCLE 1 HC	062884	TCLE 2 RC	061215
TCLE 1 FC	052940	TCLE 2 HC	061724	TCLE 3 RC	055501
TCLE 2 FC	052941	TCLE 3 HC	054395	TCLE 8 RC	063501
TCLE 3 FC	052942	TCLE 5 HC	054399		
TCLE 4 FC	052943	TCLE 7-1/2 HC	054401		
TCLE 6-1/2 FC	052944	TCLE 7-1/2 HW100	054079		
TCLE 7-1/2 FC	052945	TCLE 10 HC	054404		
TJLE 8 FC	055104	TCLE 10 HW100	059076		
TJRE 11 FC	055105	TCLE 12 HC	060854		
		TJLE 11 HC	060855		
		TJLE 14 HC	060856		
		TJRE 14 HC	060857		
		TJRE 18 HC	060858		

Standard Product Offering

TER, TIR & THR 10 FT. Cap Tube Length

Valve Description					
R-12	PCN	R-22	PCN	R-502	PCN
TER 20 FC	055109	TER 22 HC	061673	TER 14 RC	060788
TER 25 FC	055111	TER 22 HW100	058582		
		TER 26 HC	061674		
		TER 35 HC	061675		
		TER 35 HW100	058038		
		TER 45 HC	061676		
		TIR 55 HC	061677		
		THR 75 HC	064961		
		THR 100 HC	062036		
		THR 100 HW100	052912		

Standard Product Offering

Replacement Cap Screw Kits

PCN	Description	Contains Screw #	Pcs. Per Pkg.
054569	KT-30021	PS-286-5	10
054570	KT-30022	PS-168-5	10
054571	KT-30023	PS-259	10
054572	KT-30024	PS-370	10
054573	KT-30025	PS-514-5	10
054574	KT-30026	PS-517-5	10

TCLE/TJLE/TJRE Rapid Response Power Assemblies

Description	PCN
X-8019 FWS 1B	031654
X-8019 HWS 1B	055652
X-8019 HWS 2B	055873
X-8019 RWS 1A	032131
X-8019 RWS 2B	042426

Nomenclature Cross-Reference

Refrigerant	New	Old
R-12	TJLE7	TJLE800
	TJLE8	TJLE1100
R-22	TJLE11	TJLE1400
	TJLE14	TJLE1800
R-502	TJLE7	TJLE900
	TJLE9	TJLE1200

TER/TIR/THR Rapid Response Power Assemblies

Description	PCN
X-7726 FWS 2B	035083
X-7726 HWS 2B	093565
X-7726 RWS 2B	036616

Standard Product Offering

TLE Series

The TLE series is designed for air conditioning, heat pumps, transportation and commercial refrigeration. Take-Apart construction improves serviceability with replaceable/interchangeable parts. TLE valves do not have an external superheat adjustment.

Features

- Stainless steel power element eliminates corrosion and prevents valve failure
- Non-adjustable superheat to maintain factory setting
- Bi-Flow capability for heat pump applications (external equalizer required)
- Take-Apart construction for easy field service

Options

- Interchangeable capacity cages, power assemblies and flanges

Specifications

- Maximum working pressure: 450 psig
- Capscrew Torque: 300 in. lbs.

Nomenclature example: TLEB 5 HCA 5 FT 3/8 x 1/2 ODF S/T

TL	E	B	5	H	C	5 FT	3/8 x 1/2	ODF	S/T
Valve Series* Take-Apart	Equalizer E=External 1/4" SAE Standard 1/4" ODF Available (Omit for Internal)	Bleed Hole (optional) B=Bleed Hole (Omit for no bleed hole)	Capacity Nominal Rating in Tons (See Cage Capacity Table)	Refrigerant Code • F = R-12 • H = R-22 • M = R-134a • N = R-407C • P = R-507 • R = R-502 • S = R-404A	Charge Code C = medium temp CA = heat pump W(MOP) = press. limiting Z = low temp	Capillary Tube Length 5 FT (std)	Inlet x Outlet Connection Sizes Various sizes are available (valve is available also less flange)	Connection Type SAE=flare ODF=solder	Configuration ANG = 90° angle S/T = straight-thru

- + = R-12 and R-134a are interchangeable refrigerant charges
- * = R-507, R-502 and R-404A are interchangeable refrigerant charges
- = R-22 and R-407C are interchangeable refrigerant charges

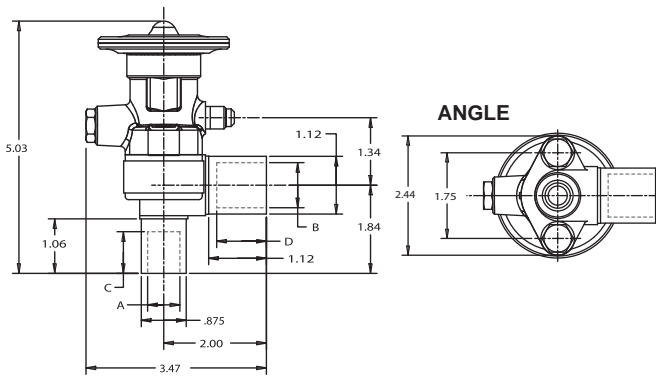

Dimensional Data (in)

TLE Angle

Connection Size		A	B	C	D
Inlet	Outlet			MIN	MIN
ODF:ODM	ODF:ODM	0.63	0.88	0.81	1.00
5/8:7/8	7/8:1-1/8				

TLE Straight Thru

Connection Size		A	B	C	D	E	F
Inlet	Outlet			MIN	MIN		
5/8 ODF	1-1/8 ODF	0.63	1.13	0.53	0.91	1.63	2.50
7/8 ODF	1-1/8 ODF	0.88	1.13	0.75	0.91	1.94	2.50
7/8 ODF	1-3/8 ODF	0.88	1.38	0.75	0.97	1.94	2.69

Allow 2-1/8" above valve for removal of power assembly.

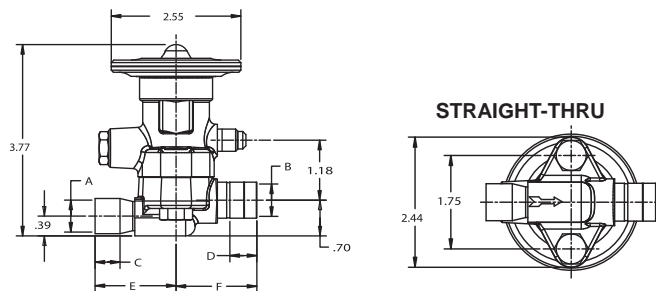

TLE Series

Ordering Information

Valve Less Flange (VLF)

Valve Less Flange ¹	PCN	Equalizer Type	Refrigerant
TLE 1/2 HW	--	1/4 SAE External	R-22
TLE 1 HW	--		
TLE 2 HW	--		
TLE 3 HW	041734		
TLE 5 HW	054793		
TLE 7-1/2 HW	054794		
TLE 10 HW	055125		
TLE 12 HW	054795		

¹Also available with "HCA" charge for heat pump and air conditioning applications.

Standard Product Offering

Cage Capacities in Tons

PCN	Description	R-12	R-134A	R-22/R-407C	R-404/R-507/ R-502
041551	X-22517 B1B	1/4	1/4	1/2	1/4
041556	X-22517 B3B	1	1-1/2	2	1
041560	X-22517 B4A	2	2-1/2	3	2
041558	X-22517 B4B	2	2-1/2	3	2
041562	X-22517 B5B	3	3-1/2	5	3
041564	X-22517 B6B	4	5-1/2	7-1/2	4-1/2
041566	X-22517 B7B	6-1/2	7-1/2	10	7

Standard Product Offering

Flanges

PCN	Description	Connections
027770	9761-2	1/2 X 7/8 ODF S/T
027771	9761-3	3/8 X 5/8 ODF S/T
027268	9761-4	1/2 X 5/8 ODF S/T
027769	9761-5	3/8 X 1/2 ODF S/T
027766	9761-6	1/2 X 1/2 ODF S/T
027764	A-576	5/8 X 7/8 ODF ANG
056932	C-500-4	3/8 X 1/2 SAE ANG
057153	C-500-5	3/8 X 5/8 SAE ANG
056294	C-500-6	1/2 X 5/8 SAE ANG
065527	C-501-4	3/8 X 1/2 ODF ANG
065748	C-504-5	3/8 X 5/8 ODF ANG
065861	C-504-7	1/2 X 5/8 ODF ANG
044733	X-6346-16	5/8 X 5/8 ODF S/T
044846	X-6346-17	5/8 X 7/8 ODF S/T
094038	X-6346-18	5/8 X 1-1/8 ODF S/T
071757	X-6346-34	7/8 X 1-1/8 ODF S/T
050563	X-6669-1	3/8 X 5/8 SAE S/T
050842	X-6669-2	1/2 X 5/8 SAE S/T
051176	X-6669-4	3/8 X 1/2 SAE S/T
083378	X-6669-5	1/2 X 1/2 SAE S/T

Standard Product Offering

Replacement Power Assemblies

PCN	Description
083765	XB1033 FW25-1B
061760	XB1033 HW-1B
077201	XB1033 HW-15A
089748	XB1033 HW-75B
095534	XB1033 HW100-15B
095813	XB1033 HW100-1B

Standard Product Offering

Power Assembly Nomenclature

Description
XB-1033 XXX-YZ
xxx = charge code
y = cap tube length code
z = internal (A) or external (B) equalizer

TFE R-22 Series

The TFE R-22 series is designed for large tonnage heat pump, air conditioning, and commercial refrigeration applications.

Features

- Stainless steel power element eliminates corrosion and prevents valve failure
- Replaceable power element
- External superheat adjustment
- ODF connections
- Balanced port construction compensates for changes in operating pressures due to varying ambients, or widely varying evaporator loads
- Bi-directional control capability
- External equalizer



Specifications

- Maximum working pressure: 450 psig

TFE Nominal* Capacity Table in Tons

R-134a	R-22/R-407C	R-502, R-404a/R-507
6	8	5
8	10	7
10	12	9
15	20	14

*See Extended Capacity Tables for ratings at a wide range of conditions per ARI standard 750

Nomenclature example: TFES 10 HCA 5/8 x 7/8 ODF S/T

TF	E	S	10	H	CA	5/8 x 7/8	ODF	S/T
Valve Series Balanced Port, Replaceable Power Assembly	Equalizer E=External 1/4" ODF	Connection Type S = solder (Only)	Capacity Nominal Rating in Tons (See nominal capacity table below)	Refrigerant Code • H = R-22 M = R-134a • N = R-407C *P = R-507 *R = R-502 *S = R-404A	Charge Code C = medium temp CA = heat pump	Inlet x Outlet Connection Sizes (See ordering information table below)	Connection Type ODF=solder	Configuration S/T = Straight- thru

* = R-507, R-502 and R-404A are interchangeable refrigerant charges, • = R-22 and R-407C are interchangeable refrigerant charges

Ordering Information

Valve Series	Capacity Tons* (R-22 Nominal)	Connections	PCN HCA Charge (R-22 Heat Pump)
	8	5/8 X 7/8 ODF S/T 6A ODF EE	061608
	10	5/8 X 7/8 ODF S/T 6A ODF EE	061610
	12	5/8 X 7/8 ODF S/T 6A	061609
	20	5/8 X 7/8 ODF S/T 6A	064493

Standard Product Offering

Dimensional Data (in)

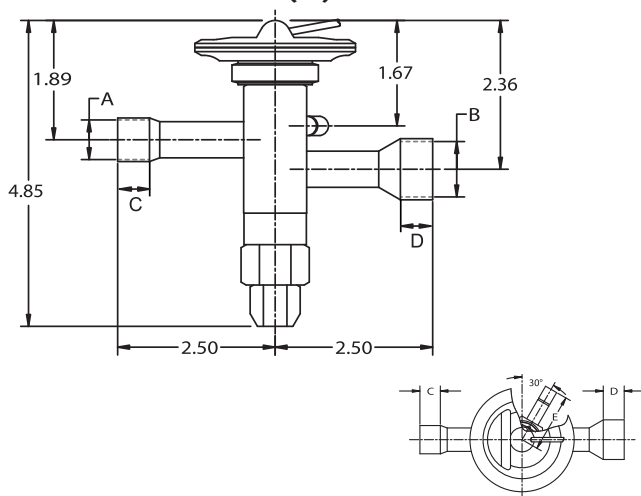

Inlet/Outlet Fittings Dimensional Data (in)

Connections	Inlet		Outlet		Equalizer			
	Inlet	Outlet	A	B	C MIN	D MIN.	1/4 ODF	SAE
1/4 ODF	3/8 ODF	0.25	0.38			0.31		
	1/2 ODF	0.25	0.50			0.37		
	5/8 ODF	0.25	0.63			0.50		
3/8 ODF	3/8 ODF	0.38	0.38		0.31	0.31		
	1/2 ODF	0.38	0.50			0.37		
	5/8 ODF	0.38	0.63			0.50		
	7/8 ODF	0.38	0.88			0.76		
1/2 ODF	1/2 ODF	0.50	0.50		0.37	0.37	1.70	1.65
	5/8 ODF	0.50	0.63		0.37	0.50		
7/8 ODF	7/8 ODF	0.50	0.88		0.37	0.76		
	1-1/8 ODF	0.63	1.13		0.50	0.91		
5/8 ODF	5/8 ODF	0.63	0.63		0.50	0.50		
	7/8 ODF	0.63	0.88		0.50	0.76		
7/8 ODF	7/8 ODF	0.88	0.88		0.76	0.76		
	1-1/8 ODF	0.88	1.13		0.76	0.91		

Remote Bulb

Charge	Tubing Length (Ft)	F	G
C,A,Z	2, 2-1/2, 5	3.06	0.63
	10	3.56	
	15, 20, 30	4.81	
	40, 50	6.19	0.76
CA, AA	2-1/2, 5, 10	2.31	

Replacement Parts

	Description	PCN
Power Assembly	X-28458 HCA-2	063414
	X-28458 HW100-2	063416
	X-28458 SW45-2	065298
Seal Nut	27676-1	058707

Standard Product Offering

TFE R-410A Series

R-410A

The TFE R-410A series is designed for large tonnage heat pump, air conditioning, and commercial refrigeration applications.



Features

- Stainless steel power element eliminates corrosion and prevents valve failure
- Replaceable power element
- External superheat adjustment
- ODF connections
- Balanced port construction compensates for changes in operating pressures due to varying ambients, or widely varying evaporator loads
- Bi-directional control capability
- External equalizer
- ZAA charge for R-410A systems

Specifications

- Maximum working pressure: 630 psig

TFE Nominal* Capacity Table in Tons

Model	Typical System Application
TFE 12	10-13 Tons
TFE 16	14-17 Tons
TFE 20	18-20 Tons

*See Extended Capacity Tables for ratings at a wide range of conditions per ARI standard 750

Nomenclature example: TFES 16 ZAA 5/8 x 7/8 ODF S/T

TF	E	S	16	Z	AA	5/8 x 7/8	ODF	S/T
Valve Series Balanced Port, Replaceable Power Assembly	Equalizer E=External ¼" ODF	Connection Type S = solder	Capacity Nominal Rating in Tons	Refrigerant Code Z = R-410A	Charge Code AA = wide range	Inlet x Outlet Connection Sizes (See ordering information table below)	Connection Type ODF=solder	Configuration S/T = Straight- thru

Ordering Information

Refrigerant	Tons	Bleed	Inlet x Outlet	Sensing Bulb Capillary Tube Length	PCN
R-410A	12	-	5/8 ODF x 7/8 ODF	5 ft.	066146
		15%	5/8 ODF x 7/8 ODF	5 ft.	066147
		-	7/8 ODF x 1-1/8 ODF	10 ft.	066148
	16	-	5/8 ODF x 7/8 ODF	5 ft.	066149
		15%	5/8 ODF x 7/8 ODF	5 ft.	066150
		-	7/8 ODF x 1-1/8 ODF	10 ft.	066151
	20	-	5/8 ODF x 7/8 ODF	5 ft.	066152
		15%	5/8 ODF x 7/8 ODF	5 ft.	066153
		-	7/8 ODF x 1-1/8 ODF	10 ft.	066154

Standard Product Offering

Inlet/Outlet Fittings Dimensional Data (in)

Connections		Inlet		Outlet	
Inlet	Outlet	A	B MIN	C	D MIN.
1/2 ODF	1/2ODF	0.50	0.37	0.50	0.37
	5/8 ODF	0.50	0.37	0.63	0.50
	7/8ODF	0.50	0.37	0.88	0.76
5/8 ODF	5/8 ODF	0.63	0.50	0.63	0.50
	7/8ODF	0.63	0.50	0.88	0.76
	1-1/8 ODF	0.63	0.50	1.13	0.91
7/8 ODF	7/8ODF	0.88	0.76	0.88	0.76
	1-1/8 ODF	0.88	0.76	1.13	0.91

Replacement Parts

Description	PCN
R-410A Power Assembly (10 ft.)*	066155*
Seal Nut	058707

*Approved for use only on TFE-Series R-410A valves (with ZAA charge)

Standard Product Offering

Dimensional Data (in)

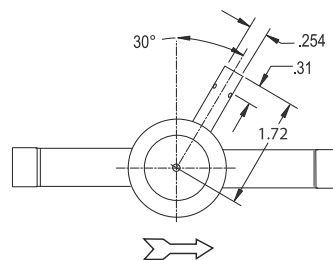
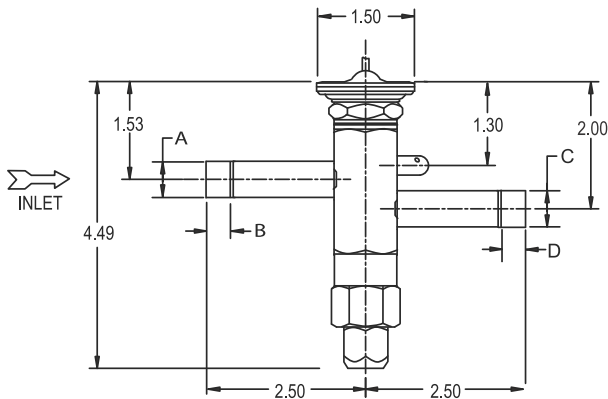

TI Series – w/Interchangeable Cartridges

The TI series has interchangeable cages capable of changing valve capacity in the field.

Features

- Stainless steel power element eliminates corrosion and prevents valve failure
- Wrench flats on inlet and outlet
- Forged brass valve body
- Inlet strainer assembly

Options

- Interchangeable capacity cages



Specifications

- Inlet connection size: 3/8" SAE, Outlet 1/2" SAE
- Maximum working pressure: 450 psig
- Maximum bulb temperature: 165°F

Nomenclature example: TIE4 HW

TI	E	4	H	W
Valve Series	Equalizer E=External (Omit for internal)	Orifice Size Valves sold less cage (Select proper cage from interchangeability table below)	Refrigerant Code • H = R-22 M = R-134a • N = R-407C *P = R-507 *S = R-404A	Charge Code W = medium temp W(MOP) = press. limiting

- * = R-507 and R-404a are interchangeable refrigerant charges
- = R-22 and R-407C are interchangeable refrigerant charges

Interchangeable Cages

Cage Size	Type	PCN	Nominal Capacity (kW)		
			R-134a	R-22/R-407C	R-404A/R-507
00	TIO-00X	065087	0.03	0.05	0.04
0	TIO-000	065088	0.08	1.30	1.00
1	TIO-001	065090	1.90	3.20	2.30
2	TIO-002	065091	3.10	5.30	3.90
3	TIO-003	065092	5.00	8.50	6.20
4	TIO-004	065093	8.30	13.90	10.10
5	TIO-005	065094	10.10	16.90	12.30
6	TIO-006	065095	11.70	19.50	14.20

NOTE: Nominal capacities shown on pages at the end of this section are based on European standards of +38°C condensing temperature, +4°C evaporating temperature and 1°K liquid subcooling at the inlet of the expansion valve. This methodology varies from the rest of the capacity tables in this catalog.

Standard Product Offering

Dimensional Data (in)

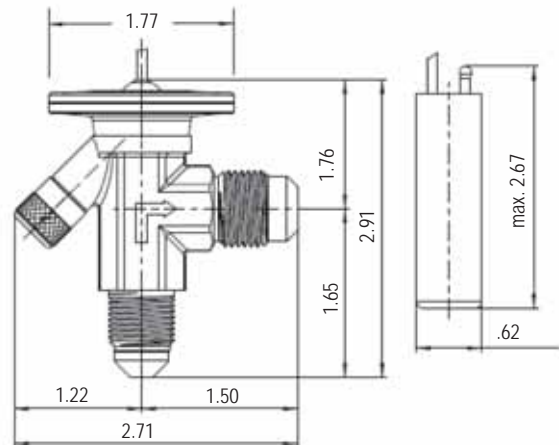

TI(E) Series – Valve bodies, Flare type

Evaporating Temp Range °F	Equalizer Type	Refrigerant					
		R-134a		R-22/R-407C		R-404A/R-507	
		Valve	PCN	Valve	PCN	Valve	PCN
-10 to +40	internal	TI-MW	066387	TI-HW	066389	TI-SW	066391
	external	TIE-MW	066388	TIE-HW	066390	TIE-SW	066392

Standard Product Offering

ZZ Series – for Ultra Low Temps

The ZZ series is designed for ultra low temperature applications such as environmental test chambers and other applications where the desired evaporator temperature is below -40°F.



Features

- Take-Apart construction for easy field service
- Improved internal construction extends valve life
- External equalizer standard
- Exclusive cage bellows eliminates friction at low temperatures
- External superheat adjustment

Specifications

Maximum working pressure: 450 psig

Options

- Interchangeable cages, power assemblies, and flanges for maximum flexibility

Nomenclature example: ZZC 6 B G125 10 FT 3/8 x 5/8 ODF ANG

ZZC	6	B	G125	10 FT	3/8 x 5/8	ODF	ANG
Valve Series Ultra Low Temperature Take-Apart	Capacity (nominal @ -40°F) Tons	Refrigerant Code B = R-13/R-23 H = R-22 R = R-502	Charge Code Z = low temp G(MOP) = press.limiting	Capillary Tube Length 10 FT (std)	Inlet x Outlet Connection Sizes	Connection Type SAE = flare ODF=solder	Configuration ANG = 90° angle S/T = straight-thru

R-13/R-23 Valve Type	R-22 Valve Type	Standard Connections
ZZC 1BG	ZZC 3/4HZ	3/8 ODF x 5/8 ODF
ZZC 2-1/2BG	ZZC 1-1/2HZ	
ZZC 4BG	ZZC 2-1/2HZ	
ZZC 6BG	ZZC 4HZ	1/2 ODF x 5/8 ODF
ZZC 9BG	ZZC 6HZ	
ZZC 13BG	ZZC 8HZ	
ZZ ER 20BG	--	7/8 ODF x 1-1/8 ODM

NOTE: Nominal capacities shown here are based upon the following conditions:

Refrigerant	Evaporator Temperature	Liquid Temperature at Valve Inlet	Pressure Drop Across Valve
R-23	-40°F	0°F	150 psig
R-22	-40°F	20°F	150 psig

ZZ Series – for Ultra Low Temps

Ordering Information

Cage Assemblies & Gaskets

Valve	Description	PCN
ZZC1BG, ZC3/4RHW, ZC3/4RW	X10110-B1B	021288
ZZC2-1/2BG, ZC1-1/2HW, ZC1-1/2RW	X10110-B2B	020871
ZZC4BG, ZC2-1/2HW, ZC2-1/2RW	X10110-B3B	096091
ZZC6BG, ZC4HW, ZC3-1/2RW	X10110-B4B	096312
ZZC9BG, ZC6HW, ZC5RW	X10110-B5B	096425
ZZC13BG, ZC8HW, ZC8RW	X10110-B6B	096646
ZZER6BG, ZZER4HW, ZC3-1/2RW	X10059-B4B	045362
ZZER9BG, ZZER6HW, ZZER5RW	X10059-B5B	033697
ZZER20BG, ZZER12HW, ZZER11RW	X10059-B6B	030071
ZZER21BG, ZZER13HW, ZZER13RW	X10059-B7B	025100
ZZER29BG, ZZER18HW, ZZER18RW	X10059-B8B	025101
ZZIR48BG, ZZIR30HW, ZZIR29RW	X10060-B10B	025090
ZZJR16BG, ZZJR10HW, ZZJR9RW	X10111-B5B	089306

Standard Product Offering

Power Assemblies

PCN	Description
094594	XC-726 BG 30-2B 10FT. SAE EE
039130	XC-726 BG 125-2B 10 FT. SAE EE
024511	XC-726 HW 35-2B 10 FT. SAE EE
025011	XC-726 HW 65-2B 10 FT. SAE EE
023357	XC-726 HW 85-3B 15 FT. SAE EE
036750	XC-726 HW 100-2B 10FT. SAE EE
040569	XC-726 HZ-2B 10FT. SAE EE

Replacement Power Assembly consists of: power assembly, and bulb clamps

Standard Product Offering

Replacement Gasket Set

PCN	Description
027579	X-13455-1

Gasket Set includes necessary body flange gasket & seat gasket

Standard Product Offering

Flanges

PCN	Description	Connections
027770	9761-2	1/2 X 7/8 ODF S/T
027771	9761-3	3/8 X 5/8 ODF S/T
027268	9761-4	1/2 X 5/8 ODF S/T
027769	9761-5	3/8 X 1/2 ODF S/T
027766	9761-6	1/2 X 1/2 ODF S/T
027764	A-576	5/8 X 7/8 ODF ANG
056932	C-500-4	3/8 X 1/2 SAE ANG
057153	C-500-5	3/8 X 5/8 SAE ANG
056294	C-500-6	1/2 X 5/8 SAE ANG
065527	C-501-4	3/8 X 1/2 ODF ANG
065748	C-501-5	3/8 X 5/8 ODF ANG
065861	C-501-7	1/2 X 5/8 ODF ANG
044733	X-6346-16	5/8 X 5/8 ODF S/T
044846	X-6346-17	5/8 X 7/8 ODF S/T
094038	X-6346-18	5/8 X 1-1/8 ODF S/T
071757	X-6346-34	7/8 X 1-1/8 ODF S/T
050563	X-6669-1	3/8 X 5/8 SAE S/T
050842	X-6669-2	1/2 X 5/8 SAE S/T
051176	X-6669-4	3/8 X 1/2 SAE S/T
083378	X-6669-5	1/2 X 1/2 SAE S/T

Standard Product Offering

LCL Take-Apart – DeSuperheating

The LCL Take-Apart series is a desuperheating (Liquid Injection) valve used in conjunction with hot gas bypass to prevent excessive suction line superheat. LCL valves can be used for interstage cooling in compound systems.



Features

- Stainless steel power element eliminates corrosion and prevents valve failure
- Take-Apart construction for easy field service

Options

- Interchangeable, replaceable cages for versatility
- External superheat adjustment
- Interchangeable body flanges
- Interchangeable power assemblies

Specifications

- Maximum working pressure: 450 psig

Nomenclature example: LCLE 2 B 5 FT 3/8 x 1/2 ODF S/T

LCL	E	2	B	5 FT	3/8 x 1/2	ODF	S/T
Valve Series De-Superheating Liquid Injection Take-Apart	Equalizer E=External (Omit for Internal)	Capacity Nominal NOTE: This is not system capacity (Contact Application Engineering for sizing)	Refrigerant Code	Capillary Tube Length 5 FT (std)	Inlet x Outlet Connection Sizes (see table below)	Connection Type SAE = flare ODF=solder	Configuration ANG = 90° angle S/T = straight-thru

Ordering Information

Description	Equalizer Type	PCN By Charge			Connections
		Select From Table Below			
		A	B	C	
LCL 1	Internal	022018	022017	--	Same as TCL & TCLE
LCL 2		022005	021996	045527	
LCL 3		055093	021987	--	
LCL 6		047759	--	--	
LCLE 1	1/4"SAE External	055096	--	--	
LCLE 2		022003	021997	--	
LCLE 3		021991	021985	--	
LCLE 4		--	061054	055097	

NOTE: Add charge suffix symbol "A", "B", or "C" based on the following table.
Example: LCLE4-A

Standard Product Offering

Replacement Valve Guide

If have:	Replace with:
LA(E)S 1/2	LCL 1
LA(E)S 1	LCL 2
LA(E)S 2	LCL 3
LA(E)S 3	LCL 4
LA(E)S 5	LCL 6
LCL 5	LCL 6
LCLE 5	LCLE 6
LCL 8	LCL 9
LCLE 8	LCLE 9

Note: Valve sizes LCL5, LCL8, LCLE5 and LCLE8 are OBSOLETE.

LCL (LA) Charge Codes

Saturated Suction	Refrigerant					
	R-134A		R-22		R-404A/R-507	
	Required Suction Gas		Required Suction Gas		Required Suction Gas	
TEMP.	45°F	65°F	45°F	65°F	45°F	65°F
40°F	--	B (GL)	--	A (CL)	--	--
30°F	B (GL)	B (GL)	--	A (CL)	--	A (CL)
20°F	B (GL)	C (UL)	A (CL)	B (GL)	--	A (CL)
10°F	B (GL)	C (UL)	B (GL)	B (GL)	A (CL)	B (GL)
0°F	C (UL)	C (UL)	B (GL)	B (GL)	A (CL)	B (GL)
-10°F	C (UL)	C (UL)	B (GL)	C (UL)	B (GL)	B (GL)
-20°F	C (UL)	C (UL)	B (GL)	C (UL)	B (GL)	C (UL)
-30°F	C (UL)	C (UL)	C (UL)	C (UL)	B (GL)	C (UL)
-40°F	C (UL)	C (UL)	C (UL)	C (UL)	B (GL)	C (UL)

() Denotes LA Series valve charge code.

LCL Take-Apart – DeSuperheating

Dimensional Data

Angle

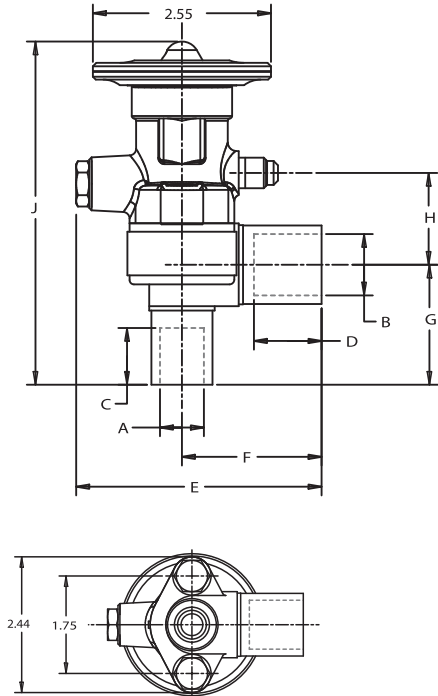

Straight-Thru

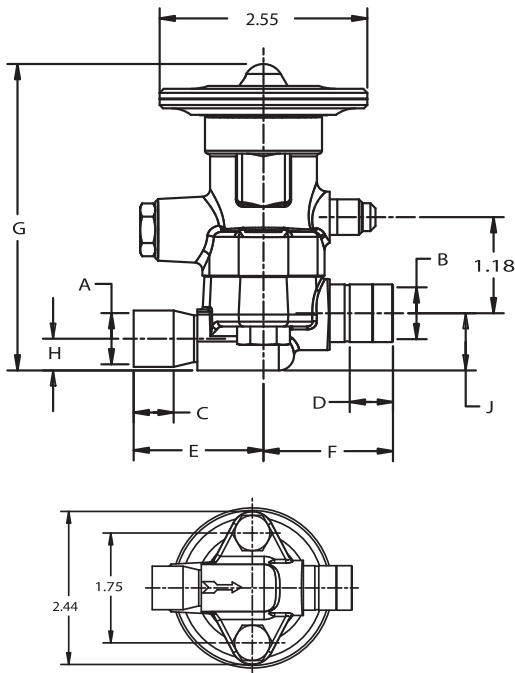

LCL(E) Dimensional Data (in)

LCL Angle

Connection Size		A	B	C MIN.	D MIN.	E	F	G	H	J
Inlet	Outlet									
3/8 SAE	1/2 SAE					3.06	1.50	1.13	1.20	4.14
3/8 SAE	5/8 SAE					3.19	1.63	1.13	1.20	4.14
1/2 SAE	5/8 SAE					3.19	1.63	1.38	1.20	4.39
1/4 ODF	3/8 ODF	0.25	0.38	0.31	0.31	2.91	1.34	0.94	1.20	3.95
3/8 ODF	1/2 ODF	0.38	0.50	0.31	0.38	3.03	1.47	1.06	1.20	4.11
3/8 ODF	5/8 ODF	0.38	0.63	0.31	0.50	3.16	1.59	1.06	1.20	4.11
1/2 ODF	5/8 ODF	0.50	0.63	0.38	0.50	3.16	1.59	1.90	1.20	4.20
5/8 ODF	7/8 ODF	0.63	0.88	0.50	0.75	3.56	2.00	1.69	1.20	4.83

LCL Straight Thru

3/8 SAE	1/2 SAE					1.78	1.98	3.70	0.38	0.69
3/8 SAE	5/8 SAE					1.78	2.16	3.70	0.38	0.69
1/2 SAE	1/2 SAE					1.97	1.56	3.70	0.38	0.69
3/8 ODF	1/2 ODF	0.38	0.50	0.31	0.38	1.41	1.58	3.69	0.38	0.69
3/8 ODF	5/8 ODF	0.38	0.63	0.31	0.50	1.41	1.63	3.69	0.36	0.67
1/2 ODF	1/2 ODF	0.50	0.50	0.38	0.38	1.41	1.56	3.70	0.38	0.69
1/2 ODF	5/8 ODF	0.50	0.63	0.38	0.50	1.59	1.63	3.69	0.36	0.67
5/8 ODF	5/8 ODF	0.63	0.63	0.50	0.50	1.59	1.63	3.70	0.38	0.69
5/8 ODF	7/8 ODF	0.63	0.88	0.50	0.75	1.59	1.94	3.70	0.38	0.69
5/8 ODF	1-1/8 ODF	0.88	1.13	0.50	0.91	1.59	2.38	3.70	0.38	0.69
7/8 ODF	1-1/8 ODF	0.88	1.13	0.75	0.91	1.94	2.38	3.81	0.38	0.69

Allow 2-1/8" above valve for removal of power assembly.

Remote Bulb Dimensions

Capillary Tubing Length (Ft)	Standard Remote Bulb	
	Diameter	Length
5	5/8	3-1/16
10		3-9/16
15 or 20		4-13/16

ACP(E) – Automatic

The ACP is designed for small cooling units where the heat load is reasonably constant. The ACP is ideal for room air conditioners, domestic refrigerators, drink dispensers, food dispensers, ice cream cabinets, bottle coolers, home freezers, ice cube makers, ice cream freezers, and milk coolers.



Features

- Friction-free floating design
- Can be used as a small capacity hot gas bypass valve
- Fully adjustable from 0-80 psig (factory setting 40 psig)
- Wrench flats on inlets and outlets

Options

- Internal or external equalizer
- SAE or ODF connections

Specifications

- Maximum working pressure: 500 psig
- Maximum working temperature: 300°F
- UL/CUL file number: SA5312

Nomenclature example: ACPE 6 SAE EE 1/4 x 3/8 ODF ANG

ACP	E	6	SAE EE	1/4 x 3/8	ODF	ANG
Valve Series	Equalizer E=External (optional)	Port Size (diameter) see table below	External Equalizer Type	Inlet x Outlet Connection Sizes	Connection Type ODF or SAE	Body Style ANG = Angle S/T = Straight-thru

Ordering Information

PCN	Description	PCN	Description
046838	ACP 1 IE 1/4 x 3/8-1/2 SAE ANG	049204	ACP 5 IE 3/8 X 3/8-1/2 SAE ANG
047652	ACP 6 IE 1/4 x 3/8 ODF ANG	047653	ACP 6 IE 1/4 x 3/8 SAE ANG
047680	ACP 1 IE 1/4 x 3/8 ODF ANG	057233	ACP 1 IE 1/4 x 3/8 ODF S/T
056240	ACP 1 IE 1/4 X 3/8 SAE ANG	065922	ACP 6 IE 3/8 x 3/8 ODF ANG
046839	ACP 2 IE 1/4 X 3/8 SAE ANG	047654	ACP 7 IE 3/8 x 1/2 ODF ANG
047651	ACP 2 IE 1/4 x 3/8 ODF ANG	047285	ACP 7 IE 3/8 x 3/8-1/2 SAE ANG
047283	ACP 3 IE 1/4 X 3/8 ODF ANG	047655	ACP 8 IE 3/8 x 1/2 ODF ANG
046840	ACP 3 IE 1/4 x 3/8 SAE ANG	047657	ACP 9 IE 3/8 X 1/2 ODF ANG
047105	ACP 4 IE 1/4 x 3/8 ODF ANG	057209	ACP 9 IE 3/8 X 3/8 ODF ANG
047101	ACP 4 IE 1/4 X 3/8 SAE ANG	057771	ACP 9 IE 1/2 x 5/8 ODF ANG
047284	ACP 5 IE 1/4 x 3/8 ODF ANG	052773	ACP 9 IE 1/4 X 3/8 ODF ANG
047332	ACP 5 IE 1/4 X 3/8 SAE ANG	047658	ACP 9 IE 3/8 x 3/8-1/2 SAE ANG
053374	ACP 5 IE 3/8 x 3/8 ODF ANG	057327	ACP 9 IE 3/8 X 3/8 SAE S/T
		047280	ACPE 1 SAE EE 1/4 x 3/8 SAE S/T
		053231	ACPE 1 SAE EE 1/4 x 3/8 ODF ANG
		047790	ACPE 7 SAE EE 3/8 x 1/2 ODF ANG
		048657	ACPE 9 SAE EE 3/8 x 1/2 ODF S/T
		058674	ACPE 9 SAE EE 1/2 x 5/8 ODF S/T
		057017	ACPE 9 ODF EE 3/8 x 1/2 ODF ANG

Standard Product Offering

ACP(E)- Nominal * Capacity Table in Tons

Valve	Port Diameter (in)	R-12/R-134a	R-407C/R-22	R-502/R-404A/R-507
		Pressure Drop Across Valve – PSI		
		60	100	100
ACP(E)1	0.05	0.31	0.44	0.29
ACP(E)2	0.06	0.41	0.57	0.38
ACP(E)3	0.10	0.65	0.91	0.61
ACP(E)4	0.11	0.90	1.30	0.87
ACP(E)5	0.13	1.40	1.96	1.31
ACP(E)6	0.14	1.90	2.67	1.78
ACP(E)7	0.17	2.30	3.28	2.19
ACP(E)8	0.20	2.70	3.75	2.50
ACP(E)9	0.23	3.80	5.32	3.55

*All capacities shown are at 100°F Condensing, 40°F Evaporator Temperature, with a solid column of liquid at the valve inlet.

ACP(E) – Automatic

ACP Dimensional Data

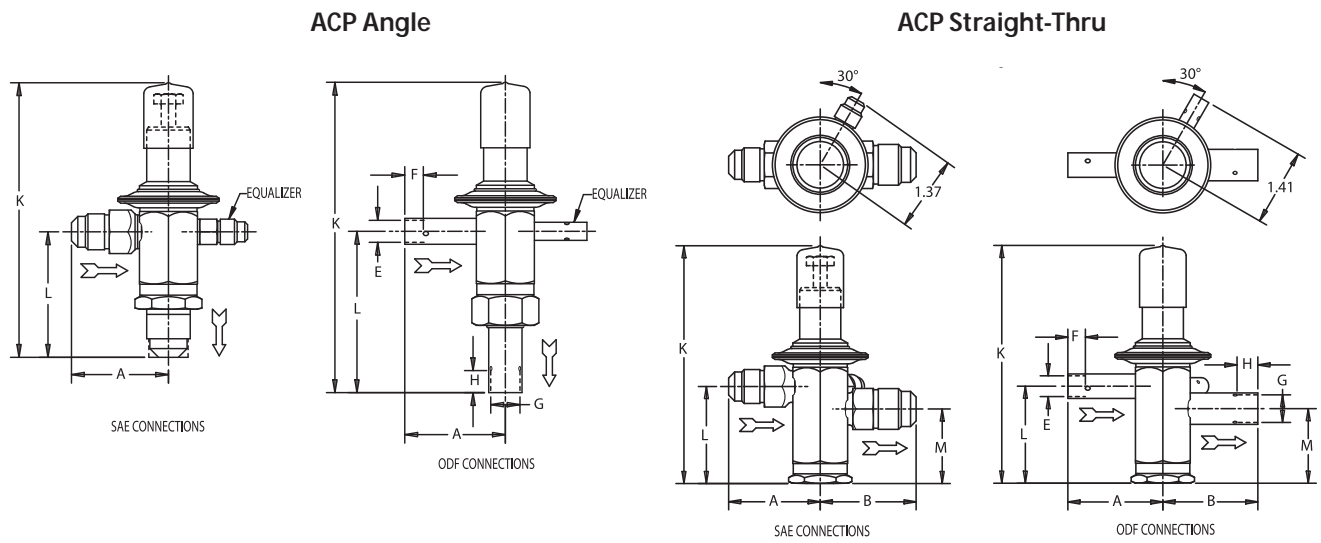

Dimensional Data (in)

ACP(E) Valve Type	Inlet	Outlet	A	B	E DIA.	F MIN.	G DIA.	H MIN.	K	L						
Angle SAE	1/4	3/8	1.50	-	-	-	-	-	4.50	2.13						
	3/8		1.64													
	1/2		1.72													
	1/4	5/8	1.50						-	-	-	-	4.61	2.23		
	3/8		1.64													
	1/2		1.72													
Angle ODF	1/4	3/8	1.25	-	0.25	0.32	0.37	0.32					4.55	2.17		
	3/8		0.37		0.32	0.50		0.38								
	1/2	1/2	1.19		-	0.50	0.38	0.62					0.50	4.73	2.36	
	5/8		1.38			0.62	0.50									
	1/4	5/8	1.25			-	0.25	0.32	0.62	0.50	4.73	2.36				
	3/8		1.19				0.37	0.32								
	1/2		1.25				0.25	0.32								
	Straight-Thru SAE	1/4	1/2				1.25	-	-	-	-	-	4.55	2.17		
		3/8					1.25									
		1/2					1.19									
1/4		5/8	1.25	-			-						-	-	4.55	2.17
3/8			1.25													
1/2			1.19													
Straight-Thru ODF	1/4	3/8	1.25		-			0.25	0.32	0.50	0.38	4.55			2.17	
	3/8		0.25			0.32		0.50	0.38							
	1/2	1/2	1.19			-		0.50	0.38	0.87	0.75	5.11			2.73	
	5/8		1.38	0.62			0.50									
	1/4	5/8	1.25	-			0.25	0.32	0.87	0.75	5.11	2.73				
	3/8		1.19				0.37	0.32								
	1/2		1.25				0.25	0.32								

ACP(E) Valve Type	Inlet	Outlet	A	B	E DIA.	F MIN.	G DIA.	H MIN.	K	L	M					
Straight-Thru SAE	1/4	3/8	1.50	1.64	-	-	-	-	4.25	1.88	1.48					
	3/8		1.64													
	1/2		1.72													
	1/4	5/8	1.50						1.98	-	-	-	-	4.25	1.88	1.48
	3/8		1.64													
	1/2		1.72													
Straight-Thru ODF	1/4	3/8	1.25	1.19	0.25	0.32	0.37	0.32						4.25	1.88	1.48
	3/8		0.37		0.32	0.50		0.38								
	1/2	1/2	1.19		1.38	0.50	0.38	0.62						0.50	4.25	1.88
	5/8		1.38			0.62	0.50									
	1/4	5/8	1.25			1.75	0.25	0.32	0.87	0.75	4.25	1.88	1.48			
	3/8		1.19				0.37	0.32								
	1/2		1.25				0.25	0.32								

R-12 Conventional Valves (Tons)– A Series and T Series

Valve Type	Nominal Rating	Evaporator Temperature																	
		50°F					40°F					20°F							
		Pressure Drop Across Valve (PSI)					Pressure Drop Across Valve (PSI)					Pressure Drop Across Valve (PSI)							
		60	80	100	125	150	175	60	80	100	125	150	175	60	80	100	125	150	175
AA/AN/AAC/ANC/AFA	1/8	0.20	0.23	0.26	0.29	0.32	0.34	0.20	0.23	0.26	0.29	0.32	0.34	0.19	0.22	0.25	0.27	0.30	0.32
AA/AN/AAC/ANC/AFA	1/4	0.35	0.40	0.45	0.51	0.55	0.60	0.34	0.39	0.44	0.49	0.54	0.58	0.33	0.38	0.43	0.48	0.52	0.56
AA/AN/AAC/ANC/AFA	1/2	0.56	0.65	0.72	0.81	0.89	0.96	0.55	0.64	0.71	0.79	0.87	0.94	0.53	0.61	0.68	0.76	0.84	0.91
AA/AN/AAC/ANC/AFA	1	0.80	0.92	1.03	1.15	1.26	1.37	0.79	0.91	1.02	1.14	1.25	1.35	0.76	0.88	0.98	1.10	1.20	1.30
AA/AN/AAC/ANC/AFA	1-1/2	1.66	1.92	2.14	2.40	2.62	2.83	1.63	1.88	2.10	2.35	2.58	2.78	1.56	1.80	2.01	2.25	2.47	2.66
AA/AN/AAC/ANC/AFA	2	2.04	2.36	2.63	2.94	3.23	3.48	2.00	2.31	2.58	2.89	3.16	3.42	1.92	2.22	2.48	2.77	3.04	3.28
AA/AN/AAC/ANC/AFA	2-1/2	2.42	2.79	3.12	3.49	3.83	4.13	2.37	2.74	3.06	3.42	3.75	4.05	2.28	2.63	2.94	3.29	3.60	3.89
AA/AN/AAC/ANC/AFA	3	3.31	3.82	4.27	4.78	5.23	5.65	3.24	3.74	4.18	4.68	5.12	5.53	3.11	3.59	4.01	4.49	4.92	5.31
TCLE	1/4	0.30	0.35	0.39	0.43	0.47	0.51	0.30	0.35	0.39	0.43	0.47	0.51	0.28	0.32	0.36	0.40	0.44	0.48
TCLE	1/2	0.57	0.66	0.74	0.82	0.90	0.97	0.56	0.65	0.72	0.81	0.89	0.96	0.53	0.61	0.68	0.76	0.84	0.91
TCLE	1	1.15	1.33	1.48	1.66	1.82	1.96	1.13	1.30	1.46	1.63	1.79	1.93	1.08	1.25	1.39	1.56	1.71	1.84
TCLE	2	2.12	2.45	2.74	3.06	3.35	3.62	2.08	2.40	2.69	3.00	3.29	3.55	1.99	2.30	2.57	2.87	3.15	3.40
TCLE	3	3.09	3.57	3.99	4.46	4.89	5.28	3.03	3.50	3.91	4.37	4.79	5.17	2.90	3.35	3.74	4.19	4.59	4.95
TCLE	4	4.48	5.17	5.78	6.47	7.08	7.65	4.39	5.07	5.67	6.34	6.94	7.50	4.21	4.86	5.44	6.08	6.66	7.19
TCLE	6-1/2	6.17	7.12	7.97	8.91	9.76	10.54	6.05	6.99	7.81	8.73	9.57	10.33	5.80	6.70	7.49	8.37	9.17	9.91
TCLE	7-1/2	7.44	8.59	9.60	10.74	11.76	12.71	7.30	8.43	9.42	10.54	11.54	12.47	7.00	8.08	9.04	10.10	11.07	11.95
TJL	7	6.59	7.61	8.51	9.51	10.42	11.25	6.47	7.47	8.35	9.34	10.23	11.05	6.20	7.16	8.00	8.95	9.80	10.59
TJL	8	8.41	9.71	10.86	12.14	13.30	14.36	8.25	9.53	10.65	11.91	13.04	14.09	7.91	9.13	10.21	11.42	12.51	13.51

Note: Standard capacity is rated at 100F liquid inlet and 40F evaporator temperature; with 60 Psi pressure drop across the TXV per ARI 750-2001.

Valve Type	Nominal Rating	Evaporator Temperature																	
		0°F					-20°F						-40°F						
		Pressure Drop Across Valve (PSI)					Pressure Drop Across Valve (PSI)						Pressure Drop Across Valve (PSI)						
		60	80	100	125	150	175	80	100	125	150	175	200	80	100	125	150	175	200
AA/AN/AAC/ANC/AFA	1/8	0.17	0.20	0.22	0.25	0.27	0.29	0.13	0.15	0.16	0.18	0.19	0.21	0.08	0.09	0.10	0.11	0.12	0.13
AA/AN/AAC/ANC/AFA	1/4	0.29	0.33	0.37	0.42	0.46	0.50	0.23	0.26	0.29	0.31	0.34	0.36	0.15	0.17	0.19	0.21	0.22	0.24
AA/AN/AAC/ANC/AFA	1/2	0.47	0.54	0.61	0.68	0.74	0.80	0.37	0.41	0.46	0.51	0.55	0.59	0.24	0.27	0.30	0.33	0.35	0.38
AA/AN/AAC/ANC/AFA	1	0.67	0.77	0.86	0.97	1.06	1.14	0.53	0.59	0.66	0.73	0.78	0.84	0.34	0.38	0.43	0.47	0.50	0.54
AA/AN/AAC/ANC/AFA	1-1/2	1.39	1.61	1.79	2.01	2.20	2.37	1.09	1.22	1.36	1.49	1.61	1.72	0.71	0.79	0.89	0.97	1.05	1.12
AA/AN/AAC/ANC/AFA	2	1.70	1.96	2.19	2.45	2.69	2.90	1.33	1.49	1.66	1.82	1.97	2.10	0.87	0.97	1.09	1.19	1.29	1.38
AA/AN/AAC/ANC/AFA	2-1/2	2.02	2.33	2.61	2.92	3.19	3.45	1.58	1.77	1.98	2.16	2.34	2.50	1.03	1.15	1.29	1.41	1.52	1.63
AA/AN/AAC/ANC/AFA	3	2.76	3.19	3.56	3.98	4.36	4.71	2.16	2.41	2.70	2.96	3.19	3.42	1.40	1.57	1.75	1.92	2.07	2.21
TCLE	1/4	0.25	0.29	0.32	0.36	0.40	0.43	0.20	0.22	0.25	0.27	0.30	0.32	0.13	0.15	0.16	0.18	0.19	0.21
TCLE	1/2	0.47	0.54	0.61	0.68	0.74	0.80	0.37	0.41	0.46	0.51	0.55	0.59	0.24	0.27	0.30	0.33	0.35	0.38
TCLE	1	0.96	1.11	1.24	1.39	1.52	1.64	0.75	0.84	0.94	1.03	1.11	1.19	0.49	0.55	0.61	0.67	0.72	0.77
TCLE	2	1.76	2.03	2.27	2.54	2.78	3.01	1.38	1.54	1.73	1.89	2.04	2.18	0.90	1.01	1.13	1.23	1.33	1.42
TCLE	3	2.57	2.97	3.32	3.71	4.06	4.39	2.01	2.25	2.51	2.75	2.97	3.18	1.31	1.46	1.64	1.79	1.94	2.07
TCLE	4	3.73	4.31	4.82	5.38	5.90	6.37	2.92	3.26	3.65	4.00	4.32	4.62	1.90	2.12	2.38	2.60	2.81	3.00
TCLE	6-1/2	5.14	5.94	6.64	7.42	8.13	8.78	4.03	4.51	5.04	5.52	5.96	6.37	2.62	2.93	3.28	3.59	3.88	4.14
TCLE	7-1/2	6.20	7.16	8.00	8.95	9.80	10.59	4.86	5.43	6.08	6.65	7.19	7.68	3.16	3.53	3.95	4.33	4.67	5.00
TJL	7	5.49	6.34	7.09	7.92	8.68	9.38	4.30	4.81	5.38	5.89	6.36	6.80	2.80	3.13	3.50	3.83	4.14	4.43
TJL	8	7.00	8.08	9.04	10.10	11.07	11.95	5.49	6.14	6.86	7.52	8.12	8.68	3.57	3.99	4.46	4.89	5.28	5.64

Refrigerant Liquid Temperature Valve Capacity Multiplier Correction Factors

	Refrigerant Liquid Temperature °F															
	0	10	20	30	40	50	60	70	80	90	100	110	120	130	140	
R-12 Correction Factor	1.60	1.54	1.48	1.42	1.36	1.30	1.24	1.18	1.12	1.06	1.00	.94	.88	.82	.75	
R-134a Correction Factor	1.70	1.63	1.56	1.49	1.42	1.36	1.29	1.21	1.14	1.07	1.00	.93	.85	.78	.71	
R-22 Correction Factor	1.56	1.51	1.45	1.40	1.34	1.29	1.23	1.17	1.12	1.06	1.00	.94	.88	.82	.76	
R-404A/R-507 Correction Factor	2.00	1.90	1.80	1.70	1.60	1.50	1.40	1.30	1.20	1.10	1.00	.90	.80	.70	.50	

These factors include corrections for liquid refrigerant density and net refrigerating effect and are based on an average evaporator temperature of 0°F. However, they may be used for any evaporator temperature from -40°F to +40°F since the variation in the actual factors across this range is insignificant.

R-22 Conventional Valves (Tons)- A Series and T Series

Valve Type	Nominal Rating	Evaporator Temperature																	
		50°F					40°F					20°F							
		Pressure Drop Across Valve (PSI)					Pressure Drop Across Valve (PSI)					Pressure Drop Across Valve (PSI)							
	60	80	100	125	150	175	60	80	100	125	150	175	60	80	100	125	150	175	
AA/AN/AFA	1/5	0.15	0.17	0.19	0.22	0.24	0.26	0.15	0.17	0.19	0.21	0.23	0.25	0.14	0.16	0.18	0.20	0.22	0.24
AA/AN/AAC/ANC/AFA	1/4	0.26	0.30	0.34	0.38	0.41	0.44	0.26	0.30	0.33	0.37	0.40	0.44	0.25	0.29	0.32	0.36	0.40	0.43
AA/AN/AAC/ANC/AFA	1/2	0.46	0.53	0.59	0.66	0.73	0.79	0.45	0.52	0.58	0.65	0.71	0.77	0.44	0.51	0.57	0.64	0.70	0.75
AA/AN/AAC/ANC/AFA	1	0.73	0.84	0.94	1.05	1.15	1.25	0.72	0.83	0.93	1.04	1.14	1.23	0.70	0.81	0.90	1.01	1.11	1.20
AA/AN/AAC/ANC/AFA	1-1/2	1.05	1.21	1.36	1.52	1.66	1.79	1.03	1.19	1.33	1.49	1.63	1.76	1.01	1.17	1.30	1.46	1.60	1.72
AA/AN/AAC/ANC/AFA	2	1.54	1.78	1.99	2.22	2.43	2.63	1.52	1.75	1.96	2.19	2.40	2.59	1.48	1.71	1.91	2.14	2.34	2.53
AA/AN/AAC/ANC/AFA	2-1/2	2.16	2.49	2.79	3.12	3.42	3.69	2.13	2.46	2.75	3.07	3.37	3.64	2.08	2.40	2.69	3.00	3.29	3.55
AA/AN/AAC/ANC/AFA	3	2.65	3.06	3.42	3.82	4.19	4.53	2.61	3.01	3.37	3.77	4.13	4.46	2.55	2.94	3.29	3.68	4.03	4.35
AA/AN/AAC/ANC/AFA	4	3.14	3.63	4.05	4.53	4.96	5.36	3.10	3.58	4.00	4.47	4.90	5.29	3.03	3.50	3.91	4.37	4.79	5.17
AA/AN/AAC/ANC/AFA	5	4.30	4.97	5.55	6.21	6.80	7.34	4.24	4.89	5.47	6.12	6.70	7.24	4.14	4.78	5.34	5.98	6.55	7.07
TCL	1/2	0.39	0.45	0.50	0.56	0.62	0.67	0.39	0.45	0.50	0.56	0.61	0.66	0.38	0.44	0.49	0.55	0.60	0.65
TCL	1	0.74	0.85	0.96	1.07	1.17	1.26	0.73	0.84	0.94	1.05	1.15	1.24	0.71	0.82	0.92	1.02	1.12	1.21
TCL	2	1.49	1.72	1.92	2.15	2.36	2.54	1.47	1.70	1.90	2.12	2.33	2.51	1.44	1.66	1.86	2.08	2.28	2.46
TCL	3	2.75	3.18	3.55	3.97	4.35	4.70	2.71	3.13	3.50	3.91	4.29	4.63	2.65	3.06	3.42	3.82	4.19	4.53
TCL	5	4.01	4.63	5.18	5.79	6.34	6.85	3.95	4.56	5.10	5.70	6.25	6.75	3.86	4.46	4.98	5.57	6.10	6.59
TCL	7-1/2	5.82	6.72	7.51	8.40	9.20	9.94	5.75	6.64	7.42	8.30	9.09	9.82	5.60	6.47	7.23	8.08	8.85	9.56
TCL	10	8.02	9.26	10.35	11.58	12.68	13.70	7.92	9.15	10.23	11.44	12.53	13.53	7.72	8.91	9.97	11.14	12.21	13.18
TCL	12	9.67	11.17	12.48	13.96	15.29	16.51	9.55	11.03	12.33	13.79	15.10	16.31	9.31	10.75	12.02	13.44	14.72	15.90
TJL	11	8.57	9.90	11.06	12.37	13.55	14.64	8.47	9.78	10.93	12.22	13.39	14.46	8.25	9.53	10.65	11.91	13.04	14.09
TJL	14	10.92	12.61	14.10	15.76	17.27	18.65	10.80	12.47	13.94	15.59	17.07	18.44	10.52	12.15	13.58	15.18	16.63	17.97

Note: Standard capacity is rated at 100F liquid inlet and 40F evaporator temperature; with 100 Psi pressure drop across the TXV per ARI 750-2001.

Valve Type	Nominal Rating	Evaporator Temperature																	
		0°F						-20°F						-40°F					
		Pressure Drop Across Valve (PSI)						Pressure Drop Across Valve (PSI)						Pressure Drop Across Valve (PSI)					
	60	80	100	125	150	175	80	100	125	150	175	200	80	100	125	150	175	200	
AA/AN/AFA	1/5	0.13	0.15	0.17	0.19	0.21	0.22	0.10	0.11	0.13	0.14	0.15	0.16	0.07	0.08	0.09	0.10	0.10	0.11
AA/AN/AAC/ANC/AFA	1/4	0.23	0.27	0.30	0.33	0.36	0.39	0.18	0.20	0.23	0.25	0.27	0.28	0.12	0.13	0.15	0.16	0.18	0.19
AA/AN/AAC/ANC/AFA	1/2	0.40	0.46	0.52	0.58	0.63	0.68	0.32	0.36	0.40	0.44	0.47	0.51	0.21	0.23	0.26	0.29	0.31	0.33
AA/AN/AAC/ANC/AFA	1	0.64	0.74	0.83	0.92	1.01	1.09	0.51	0.57	0.64	0.70	0.75	0.81	0.34	0.38	0.43	0.47	0.50	0.54
AA/AN/AAC/ANC/AFA	1-1/2	0.91	1.05	1.17	1.31	1.44	1.55	0.73	0.82	0.91	1.00	1.08	1.15	0.48	0.54	0.60	0.66	0.71	0.76
AA/AN/AAC/ANC/AFA	2	1.35	1.56	1.74	1.95	2.13	2.31	1.07	1.20	1.34	1.47	1.58	1.69	0.71	0.79	0.89	0.97	1.05	1.12
AA/AN/AAC/ANC/AFA	2-1/2	1.89	2.18	2.44	2.73	2.99	3.23	1.51	1.69	1.89	2.07	2.23	2.39	0.99	1.11	1.24	1.36	1.46	1.57
AA/AN/AAC/ANC/AFA	3	2.31	2.67	2.98	3.33	3.65	3.95	1.85	2.07	2.31	2.53	2.74	2.93	1.22	1.36	1.53	1.67	1.80	1.93
AA/AN/AAC/ANC/AFA	4	2.75	3.18	3.55	3.97	4.35	4.70	2.19	2.45	2.74	3.00	3.24	3.46	1.44	1.61	1.80	1.97	2.13	2.28
AA/AN/AAC/ANC/AFA	5	3.75	4.33	4.84	5.41	5.93	6.40	3.00	3.35	3.75	4.11	4.44	4.74	1.97	2.20	2.46	2.70	2.91	3.11
TCL	1/2	0.34	0.39	0.44	0.49	0.54	0.58	0.27	0.30	0.34	0.37	0.40	0.43	0.18	0.20	0.23	0.25	0.27	0.28
TCL	1	0.65	0.75	0.84	0.94	1.03	1.11	0.52	0.58	0.65	0.71	0.77	0.82	0.34	0.38	0.43	0.47	0.50	0.54
TCL	2	1.30	1.50	1.68	1.88	2.06	2.22	1.04	1.16	1.30	1.42	1.54	1.64	0.69	0.77	0.86	0.94	1.02	1.09
TCL	3	2.40	2.77	3.10	3.46	3.79	4.10	1.92	2.15	2.40	2.63	2.84	3.04	1.26	1.41	1.58	1.73	1.86	1.99
TCL	5	3.50	4.04	4.52	5.05	5.53	5.98	2.79	3.12	3.49	3.82	4.13	4.41	1.84	2.06	2.30	2.52	2.72	2.91
TCL	7-1/2	5.08	5.87	6.56	7.33	8.03	8.68	4.05	4.53	5.06	5.55	5.99	6.40	2.67	2.99	3.34	3.66	3.95	4.22
TCL	10	7.00	8.08	9.04	10.10	11.07	11.95	5.59	6.25	6.99	7.65	8.27	8.84	3.68	4.11	4.60	5.04	5.44	5.82
TCL	12	8.44	9.75	10.90	12.18	13.34	14.41	6.74	7.54	8.43	9.23	9.97	10.66	4.44	4.96	5.55	6.08	6.57	7.02
TJL	11	7.48	8.64	9.66	10.80	11.83	12.77	5.97	6.67	7.46	8.17	8.83	9.44	3.93	4.39	4.91	5.38	5.81	6.21
TJL	14	9.54	11.02	12.32	13.77	15.08	16.29	7.62	8.52	9.53	10.43	11.27	12.05	5.02	5.61	6.28	6.87	7.42	7.94

Refrigerant Liquid Temperature Valve Capacity Multiplier Correction Factors

	Refrigerant Liquid Temperature °F														
	0	10	20	30	40	50	60	70	80	90	100	110	120	130	140
R-12 Correction Factor	1.60	1.54	1.48	1.42	1.36	1.30	1.24	1.18	1.12	1.06	1.00	.94	.88	.82	.75
R-134a Correction Factor	1.70	1.63	1.56	1.49	1.42	1.36	1.29	1.21	1.14	1.07	1.00	.93	.85	.78	.71
R-22 Correction Factor	1.56	1.51	1.45	1.40	1.34	1.29	1.23	1.17	1.12	1.06	1.00	.94	.88	.82	.76
R-404A/R-507 Correction Factor	2.00	1.90	1.80	1.70	1.60	1.50	1.40	1.30	1.20	1.10	1.00	.90	.80	.70	.50

These factors include corrections for liquid refrigerant density and net refrigerating effect and are based on an average evaporator temperature of 0°F. However, they may be used for any evaporator temperature from -40°F to +40°F since the variation in the actual factors across this range is insignificant.

R-134a Conventional Valves (Tons)– A Series and T Series

Valve Type	Nominal Rating	Evaporator Temperature																	
		50°F					40°F					20°F							
		Pressure Drop Across Valve (PSI)					Pressure Drop Across Valve (PSI)					Pressure Drop Across Valve (PSI)							
	60	80	100	125	150	175	60	80	100	125	150	175	60	80	100	125	150	175	
AA/AN/AFA	1/8	0.14	0.16	0.18	0.20	0.22	0.24	0.14	0.16	0.18	0.20	0.22	0.24	0.13	0.15	0.17	0.19	0.21	0.22
AA/AN/AAC/ANC/AFA	1/4	0.25	0.29	0.32	0.36	0.40	0.43	0.24	0.28	0.31	0.35	0.38	0.41	0.23	0.27	0.30	0.33	0.36	0.39
AA/AN/AAC/ANC/AFA	1/2	0.43	0.50	0.56	0.62	0.68	0.73	0.43	0.50	0.56	0.62	0.68	0.73	0.41	0.47	0.53	0.59	0.65	0.70
AA/AN/AAC/ANC/AFA	3/4	0.70	0.81	0.90	1.01	1.11	1.20	0.68	0.79	0.88	0.98	1.08	1.16	0.65	0.75	0.84	0.94	1.03	1.11
AA/AN/AAC/ANC/AFA	1	1.00	1.15	1.29	1.44	1.58	1.71	0.98	1.13	1.27	1.41	1.55	1.67	0.93	1.07	1.20	1.34	1.47	1.59
AA/AN/AAC/ANC/AFA	1-1/2	1.47	1.70	1.90	2.12	2.32	2.51	1.44	1.66	1.86	2.08	2.28	2.46	1.38	1.59	1.78	1.99	2.18	2.36
AA/AN/AAC/ANC/AFA	2	2.06	2.38	2.66	2.97	3.26	3.52	2.02	2.33	2.61	2.92	3.19	3.45	1.93	2.23	2.49	2.79	3.05	3.30
AA/AN/AAC/ANC/AFA	2-1/2	2.53	2.92	3.27	3.65	4.00	4.32	2.47	2.85	3.19	3.57	3.91	4.22	2.37	2.74	3.06	3.42	3.75	4.05
AA/AN/AAC/ANC/AFA	3	3.00	3.46	3.87	4.33	4.74	5.12	2.94	3.39	3.80	4.24	4.65	5.02	2.81	3.24	3.63	4.06	4.44	4.80
AA/AN/AAC/ANC/AFA	4	4.10	4.73	5.29	5.92	6.48	7.00	4.02	4.64	5.19	5.80	6.36	6.87	3.84	4.43	4.96	5.54	6.07	6.56
TCLE	1/4	0.37	0.43	0.48	0.53	0.59	0.63	0.37	0.43	0.48	0.53	0.59	0.63	0.35	0.40	0.45	0.51	0.55	0.60
TCLE	3/4	0.70	0.81	0.90	1.01	1.11	1.20	0.69	0.80	0.89	1.00	1.09	1.18	0.66	0.76	0.85	0.95	1.04	1.13
TCLE	1-1/2	1.42	1.64	1.83	2.05	2.25	2.43	1.39	1.61	1.79	2.01	2.20	2.37	1.33	1.54	1.72	1.92	2.10	2.27
TCLE	2-1/2	2.62	3.03	3.38	3.78	4.14	4.47	2.57	2.97	3.32	3.71	4.06	4.39	2.46	2.84	3.18	3.55	3.89	4.20
TCLE	3-1/2	3.82	4.41	4.93	5.51	6.04	6.52	3.74	4.32	4.83	5.40	5.91	6.39	3.58	4.13	4.62	5.17	5.66	6.11
TCLE	5-1/2	5.55	6.41	7.17	8.01	8.78	9.48	5.43	6.27	7.01	7.84	8.59	9.27	5.20	6.00	6.71	7.51	8.22	8.88
TCLE	7-1/2	7.65	8.83	9.88	11.04	12.10	13.06	7.49	8.65	9.67	10.81	11.84	12.79	7.16	8.27	9.24	10.33	11.32	12.23
TCLE	9	9.22	10.65	11.90	13.31	14.58	15.75	9.03	10.43	11.66	13.03	14.28	15.42	8.64	9.98	11.15	12.47	13.66	14.76
TJL	9	8.17	9.43	10.55	11.79	12.92	13.95	8.00	9.24	10.33	11.55	12.65	13.66	7.65	8.83	9.88	11.04	12.10	13.06
TJL	11	10.42	12.03	13.45	15.04	16.48	17.80	10.20	11.78	13.17	14.72	16.13	17.42	9.76	11.27	12.60	14.09	15.43	16.67

Note: Standard capacity is rated at 100F liquid inlet and 40F evaporator temperature; with 60 Psi pressure drop across the TXV per ARI 750-2001.

Valve Type	Nominal Rating	Evaporator Temperature																	
		0°F					-20°F					-40°F							
		Pressure Drop Across Valve (PSI)					Pressure Drop Across Valve (PSI)					Pressure Drop Across Valve (PSI)							
	60	80	100	125	150	175	80	100	125	150	175	200	80	100	125	150	175	200	
AA/AN/AFA	1/8	0.11	0.13	0.14	0.16	0.17	0.19	0.08	0.09	0.10	0.11	0.12	0.13	0.05	0.06	0.06	0.07	0.07	0.08
AA/AN/AAC/ANC/AFA	1/4	0.19	0.22	0.25	0.27	0.30	0.32	0.14	0.16	0.18	0.19	0.21	0.22	0.09	0.10	0.11	0.12	0.13	0.14
AA/AN/AAC/ANC/AFA	1/2	0.34	0.39	0.44	0.49	0.54	0.58	0.25	0.28	0.31	0.34	0.37	0.40	0.15	0.17	0.19	0.21	0.22	0.24
AA/AN/AAC/ANC/AFA	3/4	0.54	0.62	0.70	0.78	0.85	0.92	0.40	0.45	0.50	0.55	0.59	0.63	0.25	0.28	0.31	0.34	0.37	0.40
AA/AN/AAC/ANC/AFA	1	0.77	0.89	0.99	1.11	1.22	1.32	0.57	0.64	0.71	0.78	0.84	0.90	0.35	0.39	0.44	0.48	0.52	0.55
AA/AN/AAC/ANC/AFA	1-1/2	1.13	1.30	1.46	1.63	1.79	1.93	0.85	0.95	1.06	1.16	1.26	1.34	0.52	0.58	0.65	0.71	0.77	0.82
AA/AN/AAC/ANC/AFA	2	1.59	1.84	2.05	2.29	2.51	2.72	1.19	1.33	1.49	1.63	1.76	1.88	0.73	0.82	0.91	1.00	1.08	1.15
AA/AN/AAC/ANC/AFA	2-1/2	1.95	2.25	2.52	2.81	3.08	3.33	1.45	1.62	1.81	1.99	2.14	2.29	0.89	1.00	1.11	1.22	1.32	1.41
AA/AN/AAC/ANC/AFA	3	2.31	2.67	2.98	3.33	3.65	3.95	1.72	1.92	2.15	2.36	2.54	2.72	1.06	1.19	1.33	1.45	1.57	1.68
AA/AN/AAC/ANC/AFA	4	3.16	3.65	4.08	4.56	5.00	5.40	2.36	2.64	2.95	3.23	3.49	3.73	1.45	1.62	1.81	1.99	2.14	2.29
TCLE	1/4	0.29	0.33	0.37	0.42	0.46	0.50	0.22	0.25	0.28	0.30	0.33	0.35	0.13	0.15	0.16	0.18	0.19	0.21
TCLE	3/4	0.54	0.62	0.70	0.78	0.85	0.92	0.41	0.46	0.51	0.56	0.61	0.65	0.25	0.28	0.31	0.34	0.37	0.40
TCLE	1-1/2	1.10	1.27	1.42	1.59	1.74	1.88	0.82	0.92	1.03	1.12	1.21	1.30	0.50	0.56	0.63	0.68	0.74	0.79
TCLE	2-1/2	2.02	2.33	2.61	2.92	3.19	3.45	1.51	1.69	1.89	2.07	2.23	2.39	0.93	1.04	1.16	1.27	1.38	1.47
TCLE	3-1/2	2.95	3.41	3.81	4.26	4.66	5.04	2.20	2.46	2.75	3.01	3.25	3.48	1.35	1.51	1.69	1.85	2.00	2.13
TCLE	5-1/2	4.28	4.94	5.53	6.18	6.77	7.31	3.19	3.57	3.99	4.37	4.72	5.04	1.96	2.19	2.45	2.68	2.90	3.10
TCLE	7-1/2	5.90	6.81	7.62	8.52	9.33	10.08	4.40	4.92	5.50	6.02	6.51	6.96	2.70	3.02	3.38	3.70	3.99	4.27
TCLE	9	7.11	8.21	9.18	10.26	11.24	12.14	5.30	5.93	6.63	7.26	7.84	8.38	3.26	3.64	4.08	4.46	4.82	5.15
TJL	9	6.30	7.27	8.13	9.09	9.96	10.76	4.70	5.25	5.88	6.44	6.95	7.43	2.89	3.23	3.61	3.96	4.27	4.57
TJL	11	8.03	9.27	10.37	11.59	12.70	13.71	5.99	6.70	7.49	8.20	8.86	9.47	3.68	4.11	4.60	5.04	5.44	5.82

Refrigerant Liquid Temperature Valve Capacity Multiplier Correction Factors

	Refrigerant Liquid Temperature °F														
	0	10	20	30	40	50	60	70	80	90	100	110	120	130	140
R-12 Correction Factor	1.60	1.54	1.48	1.42	1.36	1.30	1.24	1.18	1.12	1.06	1.00	.94	.88	.82	.75
R-134a Correction Factor	1.70	1.63	1.56	1.49	1.42	1.36	1.29	1.21	1.14	1.07	1.00	.93	.85	.78	.71
R-22 Correction Factor	1.56	1.51	1.45	1.40	1.34	1.29	1.23	1.17	1.12	1.06	1.00	.94	.88	.82	.76
R-404A/R-507 Correction Factor	2.00	1.90	1.80	1.70	1.60	1.50	1.40	1.30	1.20	1.10	1.00	.90	.80	.70	.50

These factors include corrections for liquid refrigerant density and net refrigerating effect and are based on an average evaporator temperature of 0°F. However, they may be used for any evaporator temperature from -40°F to +40°F since the variation in the actual factors across this range is insignificant.

R-404A/R-507 Conventional Valves (Tons)– A Series and T Series

Valve Type	Nominal Rating	Evaporator Temperature																	
		50°F					40°F					20°F							
		Pressure Drop Across Valve (PSI)					Pressure Drop Across Valve (PSI)					Pressure Drop Across Valve (PSI)							
	60	80	100	125	150	175	60	80	100	125	150	175	60	80	100	125	150	175	
AA/AN/AFA	1/8	0.11	0.13	0.14	0.16	0.17	0.19	0.11	0.13	0.14	0.16	0.17	0.19	0.10	0.12	0.13	0.14	0.16	0.17
AA/AN/AAC/ANC/AFA	1/4	0.19	0.22	0.25	0.27	0.30	0.32	0.19	0.22	0.25	0.27	0.30	0.32	0.18	0.21	0.23	0.26	0.28	0.31
AA/AN/AAC/ANC/AFA	1/2	0.33	0.38	0.43	0.48	0.52	0.56	0.33	0.38	0.43	0.48	0.52	0.56	0.31	0.36	0.40	0.45	0.49	0.53
AA/AN/AAC/ANC/AFA	3/4	0.54	0.62	0.70	0.78	0.85	0.92	0.52	0.60	0.67	0.75	0.82	0.89	0.50	0.58	0.65	0.72	0.79	0.85
AA/AN/AAC/ANC/AFA	1	0.77	0.89	0.99	1.11	1.22	1.32	0.75	0.87	0.97	1.08	1.19	1.28	0.71	0.82	0.92	1.02	1.12	1.21
AA/AN/AAC/ANC/AFA	1-1/4	1.13	1.30	1.46	1.63	1.79	1.93	1.10	1.27	1.42	1.59	1.74	1.88	1.05	1.21	1.36	1.52	1.66	1.79
AA/AN/AAC/ANC/AFA	2	1.58	1.82	2.04	2.28	2.50	2.70	1.55	1.79	2.00	2.24	2.45	2.65	1.47	1.70	1.90	2.12	2.32	2.51
AA/AN/AAC/ANC/AFA	2-1/4	1.94	2.24	2.50	2.80	3.07	3.31	1.89	2.18	2.44	2.73	2.99	3.23	1.80	2.08	2.32	2.60	2.85	3.07
AA/AN/AAC/ANC/AFA	2-1/2	2.30	2.66	2.97	3.32	3.64	3.93	2.25	2.60	2.90	3.25	3.56	3.84	2.14	2.47	2.76	3.09	3.38	3.65
AA/AN/AAC/ANC/AFA	3-1/2	3.15	3.64	4.07	4.55	4.98	5.38	3.08	3.56	3.98	4.45	4.87	5.26	2.92	3.37	3.77	4.21	4.62	4.99
TCL	1/4	0.29	0.33	0.37	0.42	0.46	0.50	0.28	0.32	0.36	0.40	0.44	0.48	0.27	0.31	0.35	0.39	0.43	0.46
TCL	1/2	0.54	0.62	0.70	0.78	0.85	0.92	0.53	0.61	0.68	0.76	0.84	0.91	0.50	0.58	0.65	0.72	0.79	0.85
TCL	1	1.09	1.26	1.41	1.57	1.72	1.86	1.07	1.24	1.38	1.54	1.69	1.83	1.01	1.17	1.30	1.46	1.60	1.72
TCL	2	2.01	2.32	2.59	2.90	3.18	3.43	1.97	2.27	2.54	2.84	3.11	3.36	1.87	2.16	2.41	2.70	2.96	3.19
TCL	3	2.94	3.39	3.80	4.24	4.65	5.02	2.87	3.31	3.71	4.14	4.54	4.90	2.72	3.14	3.51	3.93	4.30	4.65
TCL	4-1/2	4.26	4.92	5.50	6.15	6.74	7.28	4.16	4.80	5.37	6.00	6.58	7.10	3.95	4.56	5.10	5.70	6.25	6.75
TCL	7	5.87	6.78	7.58	8.47	9.28	10.02	5.73	6.62	7.40	8.27	9.06	9.79	5.45	6.29	7.04	7.87	8.62	9.31
TCL	8	7.08	8.18	9.14	10.22	11.19	12.09	6.91	7.98	8.92	9.97	10.93	11.80	6.57	7.59	8.48	9.48	10.39	11.22
TJL	7	6.27	7.24	8.09	9.05	9.91	10.71	6.13	7.08	7.91	8.85	9.69	10.47	5.82	6.72	7.51	8.40	9.20	9.94
TJL	9	8.00	9.24	10.33	11.55	12.65	13.66	7.81	9.02	10.08	11.27	12.35	13.34	7.42	8.57	9.58	10.71	11.73	12.67

Note: Standard capacity is rated at 100F liquid inlet and 40F evaporator temperature; with 100 Psi pressure drop across the TXV per ARI 750-2001.

Valve Type	Nominal Rating	Evaporator Temperature																	
		0°F					-20°F					-40°F							
		Pressure Drop Across Valve (PSI)					Pressure Drop Across Valve (PSI)					Pressure Drop Across Valve (PSI)							
	60	80	100	125	150	175	80	100	125	150	175	200	80	100	125	150	175	200	
AA/AN/AFA	1/8	0.09	0.10	0.12	0.13	0.14	0.15	0.07	0.08	0.09	0.10	0.10	0.11	0.05	0.06	0.06	0.07	0.07	0.08
AA/AN/AAC/ANC/AFA	1/4	0.16	0.18	0.21	0.23	0.25	0.27	0.12	0.13	0.15	0.16	0.18	0.19	0.08	0.09	0.10	0.11	0.12	0.13
AA/AN/AAC/ANC/AFA	1/2	0.28	0.32	0.36	0.40	0.44	0.48	0.22	0.25	0.28	0.30	0.33	0.35	0.14	0.16	0.18	0.19	0.21	0.22
AA/AN/AAC/ANC/AFA	3/4	0.44	0.51	0.57	0.64	0.70	0.75	0.35	0.39	0.44	0.48	0.52	0.55	0.23	0.26	0.29	0.31	0.34	0.36
AA/AN/AAC/ANC/AFA	1	0.63	0.73	0.81	0.91	1.00	1.08	0.50	0.56	0.63	0.68	0.74	0.79	0.32	0.36	0.40	0.44	0.47	0.51
AA/AN/AAC/ANC/AFA	1-1/4	0.93	1.07	1.20	1.34	1.47	1.59	0.73	0.82	0.91	1.00	1.08	1.15	0.48	0.54	0.60	0.66	0.71	0.76
AA/AN/AAC/ANC/AFA	2	1.31	1.51	1.69	1.89	2.07	2.24	1.03	1.15	1.29	1.41	1.52	1.63	0.67	0.75	0.84	0.92	0.99	1.06
AA/AN/AAC/ANC/AFA	2-1/4	1.61	1.86	2.08	2.32	2.55	2.75	1.26	1.41	1.58	1.73	1.86	1.99	0.82	0.92	1.03	1.12	1.21	1.30
AA/AN/AAC/ANC/AFA	2-1/2	1.91	2.21	2.47	2.76	3.02	3.26	1.50	1.68	1.88	2.05	2.22	2.37	0.98	1.10	1.23	1.34	1.45	1.55
AA/AN/AAC/ANC/AFA	3-1/2	2.61	3.01	3.37	3.77	4.13	4.46	2.04	2.28	2.55	2.79	3.02	3.23	1.34	1.50	1.68	1.83	1.98	2.12
TCL	1/4	0.24	0.28	0.31	0.35	0.38	0.41	0.19	0.21	0.24	0.26	0.28	0.30	0.12	0.13	0.15	0.16	0.18	0.19
TCL	1/2	0.45	0.52	0.58	0.65	0.71	0.77	0.35	0.39	0.44	0.48	0.52	0.55	0.23	0.26	0.29	0.31	0.34	0.36
TCL	1	0.91	1.05	1.17	1.31	1.44	1.55	0.71	0.79	0.89	0.97	1.05	1.12	0.46	0.51	0.58	0.63	0.68	0.73
TCL	2	1.67	1.93	2.16	2.41	2.64	2.85	1.31	1.46	1.64	1.79	1.94	2.07	0.86	0.96	1.08	1.18	1.27	1.36
TCL	3	2.43	2.81	3.14	3.51	3.84	4.15	1.91	2.14	2.39	2.62	2.82	3.02	1.25	1.40	1.56	1.71	1.85	1.98
TCL	4-1/2	3.53	4.08	4.56	5.10	5.58	6.03	2.77	3.10	3.46	3.79	4.10	4.38	1.81	2.02	2.26	2.48	2.68	2.86
TCL	7	4.86	5.61	6.27	7.01	7.68	8.30	3.81	4.26	4.76	5.22	5.64	6.02	2.49	2.78	3.11	3.41	3.68	3.94
TCL	8	5.86	6.77	7.57	8.46	9.27	10.01	4.60	5.14	5.75	6.30	6.80	7.27	3.01	3.37	3.76	4.12	4.45	4.76
TJL	7	5.19	5.99	6.70	7.49	8.21	8.86	4.07	4.55	5.09	5.57	6.02	6.44	2.66	2.97	3.33	3.64	3.93	4.21
TJL	9	6.62	7.64	8.55	9.56	10.47	11.31	5.20	5.81	6.50	7.12	7.69	8.22	3.40	3.80	4.25	4.66	5.03	5.38

Refrigerant Liquid Temperature Valve Capacity Multiplier Correction Factors

	Refrigerant Liquid Temperature °F															
	0	10	20	30	40	50	60	70	80	90	100	110	120	130	140	
R-12 Correction Factor	1.60	1.54	1.48	1.42	1.36	1.30	1.24	1.18	1.12	1.06	1.00	.94	.88	.82	.75	
R-134a Correction Factor	1.70	1.63	1.56	1.49	1.42	1.36	1.29	1.21	1.14	1.07	1.00	.93	.85	.78	.71	
R-22 Correction Factor	1.56	1.51	1.45	1.40	1.34	1.29	1.23	1.17	1.12	1.06	1.00	.94	.88	.82	.76	
R-404A/R-507 Correction Factor	2.00	1.90	1.80	1.70	1.60	1.50	1.40	1.30	1.20	1.10	1.00	.90	.80	.70	.50	

These factors include corrections for liquid refrigerant density and net refrigerating effect and are based on an average evaporator temperature of 0°F. However, they may be used for any evaporator temperature from -40°F to +40°F since the variation in the actual factors across this range is insignificant.

Thermal Expansion Valves
 TXV Extended Capacity Tables
 EX Valves and Controls
 Solenoid Valves and Coils
 Solenoid Capacity Tables
 Industrial Solenoid Valves
 Shut Off Valves
 System Protectors
 System Protectors Capacity Tables
 Oil Controls
 Temperature Pressure Controls

R-407C Conventional Valves (Tons)– A Series and T Series

Valve Type	Nominal Rating	Evaporator Temperature																	
		50°F						40°F						20°F					
		Pressure Drop Across Valve (PSI)						Pressure Drop Across Valve (PSI)						Pressure Drop Across Valve (PSI)					
		60	80	100	125	150	175	60	80	100	125	150	175	60	80	100	125	150	175
AA/AN/AFA	1/5	0.14	0.16	0.18	0.20	0.22	0.24	0.14	0.16	0.18	0.20	0.22	0.24	0.14	0.16	0.18	0.20	0.22	0.24
AA/AN/AAC/ANC/AFA	1/4	0.25	0.29	0.32	0.36	0.40	0.43	0.24	0.28	0.31	0.35	0.38	0.41	0.23	0.27	0.30	0.33	0.36	0.39
AA/AN/AAC/ANC/AFA	1/2	0.44	0.51	0.57	0.64	0.70	0.75	0.43	0.50	0.56	0.62	0.68	0.73	0.41	0.47	0.53	0.59	0.65	0.70
AA/AN/AAC/ANC/AFA	1	0.70	0.81	0.90	1.01	1.11	1.20	0.69	0.80	0.89	1.00	1.09	1.18	0.66	0.76	0.85	0.95	1.04	1.13
AA/AN/AAC/ANC/AFA	1-1/4	1.00	1.15	1.29	1.44	1.58	1.71	0.98	1.13	1.27	1.41	1.55	1.67	0.95	1.10	1.23	1.37	1.50	1.62
AA/AN/AAC/ANC/AFA	2	1.48	1.71	1.91	2.14	2.34	2.53	1.45	1.67	1.87	2.09	2.29	2.48	1.39	1.61	1.79	2.01	2.20	2.37
AA/AN/AAC/ANC/AFA	2-1/2	2.07	2.39	2.67	2.99	3.27	3.54	2.04	2.36	2.63	2.94	3.23	3.48	1.95	2.25	2.52	2.81	3.08	3.33
AA/AN/AAC/ANC/AFA	3-1/4	2.54	2.93	3.28	3.67	4.02	4.34	2.49	2.88	3.21	3.59	3.94	4.25	2.39	2.76	3.09	3.45	3.78	4.08
AA/AN/AAC/ANC/AFA	4	3.02	3.49	3.90	4.36	4.78	5.16	2.96	3.42	3.82	4.27	4.68	5.06	2.84	3.28	3.67	4.10	4.49	4.85
AA/AN/AAC/ANC/AFA	5-1/4	4.12	4.76	5.32	5.95	6.51	7.04	4.05	4.68	5.23	5.85	6.40	6.92	3.89	4.49	5.02	5.61	6.15	6.64
TCLC	1/2	0.38	0.44	0.49	0.55	0.60	0.65	0.37	0.43	0.48	0.53	0.59	0.63	0.36	0.42	0.46	0.52	0.57	0.61
TCLC	1	0.71	0.82	0.92	1.02	1.12	1.21	0.70	0.81	0.90	1.01	1.11	1.20	0.67	0.77	0.86	0.97	1.06	1.14
TCLC	2	1.43	1.65	1.85	2.06	2.26	2.44	1.41	1.63	1.82	2.04	2.23	2.41	1.35	1.56	1.74	1.95	2.13	2.31
TCLC	3	2.64	3.05	3.41	3.81	4.17	4.51	2.59	2.99	3.34	3.74	4.10	4.42	2.49	2.88	3.21	3.59	3.94	4.25
TCLC	5	3.85	4.45	4.97	5.56	6.09	6.58	3.77	4.35	4.87	5.44	5.96	6.44	3.62	4.18	4.67	5.23	5.72	6.18
TCLC	7-1/2	5.58	6.44	7.20	8.05	8.82	9.53	5.48	6.33	7.07	7.91	8.66	9.36	5.26	6.07	6.79	7.59	8.32	8.98
TCLC	10	7.69	8.88	9.93	11.10	12.16	13.13	7.55	8.72	9.75	10.90	11.94	12.89	7.25	8.37	9.36	10.46	11.46	12.38
TCLC	12	9.27	10.70	11.97	13.38	14.66	15.83	9.10	10.51	11.75	13.13	14.39	15.54	8.74	10.09	11.28	12.62	13.82	14.93
TJL	11	8.22	9.49	10.61	11.86	13.00	14.04	8.07	9.32	10.42	11.65	12.76	13.78	7.75	8.95	10.01	11.19	12.25	13.24
TJL	14	10.48	12.10	13.53	15.13	16.57	17.90	10.29	11.88	13.28	14.85	16.27	17.57	9.88	11.41	12.76	14.26	15.62	16.87

Note: Standard capacity is rated at 100F liquid inlet and 40F evaporator temperature; with 100 Psi pressure drop across the TXV per ARI 750-2001.

Valve Type	Nominal Rating	Evaporator Temperature																	
		0°F						-20°F						-40°F					
		Pressure Drop Across Valve (PSI)						Pressure Drop Across Valve (PSI)						Pressure Drop Across Valve (PSI)					
		60	80	100	125	150	175	80	100	125	150	175	200	80	100	125	150	175	200
AA/AN/AFA	1/5	0.11	0.13	0.14	0.16	0.17	0.19	0.09	0.10	0.11	0.12	0.13	0.14	0.05	0.06	0.06	0.07	0.07	0.08
AA/AN/AAC/ANC/AFA	1/4	0.20	0.23	0.26	0.29	0.32	0.34	0.15	0.17	0.19	0.21	0.22	0.24	0.09	0.10	0.11	0.12	0.13	0.14
AA/AN/AAC/ANC/AFA	1/2	0.35	0.40	0.45	0.51	0.55	0.60	0.26	0.29	0.33	0.36	0.38	0.41	0.17	0.19	0.21	0.23	0.25	0.27
AA/AN/AAC/ANC/AFA	1	0.56	0.65	0.72	0.81	0.89	0.96	0.42	0.47	0.53	0.58	0.62	0.66	0.27	0.30	0.34	0.37	0.40	0.43
AA/AN/AAC/ANC/AFA	1-1/4	0.80	0.92	1.03	1.15	1.26	1.37	0.61	0.68	0.76	0.84	0.90	0.96	0.38	0.42	0.48	0.52	0.56	0.60
AA/AN/AAC/ANC/AFA	2	1.18	1.36	1.52	1.70	1.87	2.02	0.90	1.01	1.13	1.23	1.33	1.42	0.56	0.63	0.70	0.77	0.83	0.89
AA/AN/AAC/ANC/AFA	2-1/2	1.65	1.91	2.13	2.38	2.61	2.82	1.26	1.41	1.58	1.73	1.86	1.99	0.79	0.88	0.99	1.08	1.17	1.25
AA/AN/AAC/ANC/AFA	3-1/4	2.02	2.33	2.61	2.92	3.19	3.45	1.54	1.72	1.93	2.11	2.28	2.43	0.97	1.08	1.21	1.33	1.43	1.53
AA/AN/AAC/ANC/AFA	4	2.40	2.77	3.10	3.46	3.79	4.10	1.83	2.05	2.29	2.51	2.71	2.89	1.15	1.29	1.44	1.57	1.70	1.82
AA/AN/AAC/ANC/AFA	5-1/4	3.28	3.79	4.23	4.73	5.19	5.60	2.50	2.80	3.13	3.42	3.70	3.95	1.57	1.76	1.96	2.15	2.32	2.48
TCLC	1/2	0.30	0.35	0.39	0.43	0.47	0.51	0.23	0.26	0.29	0.31	0.34	0.36	0.14	0.16	0.18	0.19	0.21	0.22
TCLC	1	0.56	0.65	0.72	0.81	0.89	0.96	0.43	0.48	0.54	0.59	0.64	0.68	0.27	0.30	0.34	0.37	0.40	0.43
TCLC	2	1.14	1.32	1.47	1.65	1.80	1.95	0.87	0.97	1.09	1.19	1.29	1.38	0.55	0.61	0.69	0.75	0.81	0.87
TCLC	3	2.10	2.42	2.71	3.03	3.32	3.59	1.60	1.79	2.00	2.19	2.37	2.53	1.01	1.13	1.26	1.38	1.49	1.60
TCLC	5	3.06	3.53	3.95	4.42	4.84	5.23	2.33	2.61	2.91	3.19	3.45	3.68	1.47	1.64	1.84	2.01	2.17	2.32
TCLC	7-1/2	4.44	5.13	5.73	6.41	7.02	7.58	3.38	3.78	4.23	4.63	5.00	5.34	2.13	2.38	2.66	2.92	3.15	3.37
TCLC	10	6.12	7.07	7.90	8.83	9.68	10.45	4.66	5.21	5.83	6.38	6.89	7.37	2.93	3.28	3.66	4.01	4.33	4.63
TCLC	12	7.38	8.52	9.53	10.65	11.67	12.60	5.62	6.28	7.03	7.70	8.31	8.89	3.54	3.96	4.43	4.85	5.24	5.60
TJL	11	6.54	7.55	8.44	9.44	10.34	11.17	4.98	5.57	6.23	6.82	7.37	7.87	3.13	3.50	3.91	4.29	4.63	4.95
TJL	14	8.34	9.63	10.77	12.04	13.19	14.24	6.35	7.10	7.94	8.70	9.39	10.04	4.00	4.47	5.00	5.48	5.92	6.32

Refrigerant Liquid Temperature Valve Capacity Multiplier Correction Factors

	Refrigerant Liquid Temperature °F															
	0	10	20	30	40	50	60	70	80	90	100	110	120	130	140	
R-12 Correction Factor	1.60	1.54	1.48	1.42	1.36	1.30	1.24	1.18	1.12	1.06	1.00	.94	.88	.82	.75	
R-134a Correction Factor	1.70	1.63	1.56	1.49	1.42	1.36	1.29	1.21	1.14	1.07	1.00	.93	.85	.78	.71	
R-22 Correction Factor	1.56	1.51	1.45	1.40	1.34	1.29	1.23	1.17	1.12	1.06	1.00	.94	.88	.82	.76	
R-404A/R-507 Correction Factor	2.00	1.90	1.80	1.70	1.60	1.50	1.40	1.30	1.20	1.10	1.00	.90	.80	.70	.50	

These factors include corrections for liquid refrigerant density and net refrigerating effect and are based on an average evaporator temperature of 0°F. However, they may be used for any evaporator temperature from -40°F to +40°F since the variation in the actual factors across this range is insignificant.

R-410A Conventional Valves (Tons)– A Series

Valve Type	Nominal Rating	Evaporator Temperature																	
		50°F					40°F					20°F							
		Pressure Drop Across Valve (PSI)					Pressure Drop Across Valve (PSI)					Pressure Drop Across Valve (PSI)							
		110	140	160	210	245	285	110	140	160	210	245	285	110	140	160	210	245	285
AA/AN/AAC/ANC/AFA	1/4	0.34	0.38	0.41	0.47	0.51	0.55	0.34	0.38	0.41	0.47	0.51	0.55	0.33	0.37	0.40	0.46	0.49	0.53
AA/AN/AAC/ANC/AFA	1/2	0.60	0.68	0.72	0.83	0.90	0.97	0.59	0.67	0.71	0.82	0.88	0.95	0.58	0.65	0.70	0.80	0.87	0.93
AA/AN/AAC/ANC/AFA	1	0.96	1.08	1.16	1.33	1.43	1.55	0.95	1.07	1.15	1.31	1.42	1.53	0.93	1.05	1.12	1.28	1.39	1.50
AA/AN/AAC/ANC/AFA	1-1/2	1.38	1.56	1.66	1.91	2.06	2.22	1.36	1.53	1.64	1.88	2.03	2.19	1.33	1.50	1.60	1.84	1.98	2.14
AA/AN/AAC/ANC/AFA	2	2.03	2.29	2.45	2.80	3.03	3.27	2.01	2.27	2.42	2.78	3.00	3.24	1.96	2.21	2.36	2.71	2.93	3.15
AA/AN/AAC/ANC/AFA	3	2.85	3.22	3.44	3.94	4.25	4.59	2.82	3.18	3.40	3.90	4.21	4.54	2.74	3.09	3.30	3.79	4.09	4.41
AA/AN/AAC/ANC/AFA	4	3.49	3.94	4.21	4.82	5.21	5.62	3.45	3.89	4.16	4.77	5.15	5.55	3.36	3.79	4.05	4.64	5.01	5.41
AA/AN/AAC/ANC/AFA	5	4.14	4.67	4.99	5.72	6.18	6.66	4.10	4.63	4.94	5.66	6.12	6.60	3.99	4.50	4.81	5.51	5.95	6.42

Note: Standard capacity is rated at 100F liquid inlet and 40F evaporator temperature; with 160 Psi pressure drop across the TXV per ARI 750-2001.

Valve Type	Nominal Rating	Evaporator Temperature																	
		0°F				-20°F				-40°F									
		Pressure Drop Across Valve (PSI)				Pressure Drop Across Valve (PSI)				Pressure Drop Across Valve (PSI)									
		140	160	210	245	285	330	140	160	210	245	285	330	140	160	210	245	285	330
AA/AN/AAC/ANC/AFA	1/4	0.34	0.36	0.42	0.45	0.49	0.52	0.24	0.26	0.29	0.32	0.34	0.37	0.16	0.17	0.20	0.21	0.23	0.25
AA/AN/AAC/ANC/AFA	1/2	0.60	0.64	0.73	0.79	0.86	0.92	0.41	0.44	0.50	0.54	0.58	0.63	0.27	0.29	0.33	0.36	0.39	0.41
AA/AN/AAC/ANC/AFA	1	0.95	1.02	1.16	1.26	1.36	1.46	0.66	0.71	0.81	0.87	0.94	1.01	0.44	0.47	0.54	0.58	0.63	0.68
AA/AN/AAC/ANC/AFA	1-1/2	1.36	1.45	1.67	1.80	1.94	2.09	0.95	1.02	1.16	1.26	1.36	1.46	0.63	0.67	0.77	0.83	0.90	0.97
AA/AN/AAC/ANC/AFA	2	2.01	2.15	2.46	2.66	2.87	3.09	1.40	1.50	1.71	1.85	2.00	2.15	0.93	0.99	1.14	1.23	1.33	1.43
AA/AN/AAC/ANC/AFA	3	2.82	3.01	3.45	3.73	4.02	4.33	1.96	2.10	2.40	2.59	2.80	3.01	1.30	1.39	1.59	1.72	1.85	2.00
AA/AN/AAC/ANC/AFA	4	3.46	3.70	4.24	4.58	4.94	5.31	2.40	2.57	2.94	3.17	3.42	3.68	1.60	1.71	1.96	2.12	2.28	2.46
AA/AN/AAC/ANC/AFA	5	4.10	4.38	5.02	5.42	5.85	6.29	2.85	3.05	3.49	3.77	4.07	4.38	1.89	2.02	2.31	2.50	2.70	2.90

Refrigerant Liquid Temperature Valve Capacity Multiplier Correction Factors

	Refrigerant Liquid Temperature °F															
	0	10	20	30	40	50	60	70	80	90	100	110	120	130	140	
R-12 Correction Factor	1.60	1.54	1.48	1.42	1.36	1.30	1.24	1.18	1.12	1.06	1.00	.94	.88	.82	.75	
R-134a Correction Factor	1.70	1.63	1.56	1.49	1.42	1.36	1.29	1.21	1.14	1.07	1.00	.93	.85	.78	.71	
R-22 Correction Factor	1.56	1.51	1.45	1.40	1.34	1.29	1.23	1.17	1.12	1.06	1.00	.94	.88	.82	.76	
R-404A/R-507 Correction Factor	2.00	1.90	1.80	1.70	1.60	1.50	1.40	1.30	1.20	1.10	1.00	.90	.80	.70	.50	

These factors include corrections for liquid refrigerant density and net refrigerating effect and are based on an average evaporator temperature of 0°F. However, they may be used for any evaporator temperature from -40°F to +40°F since the variation in the actual factors across this range is insignificant.

R-502 Conventional Valves (Tons)– A Series and T Series

Valve Type	Nominal Rating	Evaporator Temperature																	
		50°F					40°F					20°F							
		Pressure Drop Across Valve (PSI)					Pressure Drop Across Valve (PSI)					Pressure Drop Across Valve (PSI)							
	60	80	100	125	150	175	60	80	100	125	150	175	60	80	100	125	150	175	
AA/AN/AAC/ANC/AFA	1/8	0.17	0.20	0.22	0.25	0.27	0.29	0.17	0.20	0.22	0.25	0.27	0.29	0.16	0.18	0.21	0.23	0.25	0.27
AA/AN/AAC/ANC/AFA	1/4	0.30	0.35	0.39	0.43	0.47	0.51	0.29	0.33	0.37	0.42	0.46	0.50	0.28	0.32	0.36	0.40	0.44	0.48
AA/AN/AAC/ANC/AFA	1/2	0.48	0.55	0.62	0.69	0.76	0.82	0.47	0.54	0.61	0.68	0.74	0.80	0.45	0.52	0.58	0.65	0.71	0.77
AA/AN/AAC/ANC/AFA	1	0.68	0.79	0.88	0.98	1.08	1.16	0.67	0.77	0.86	0.97	1.06	1.14	0.64	0.74	0.83	0.92	1.01	1.09
AA/AN/AAC/ANC/AFA	1-1/2	1.41	1.63	1.82	2.04	2.23	2.41	1.38	1.59	1.78	1.99	2.18	2.36	1.32	1.52	1.70	1.91	2.09	2.25
AA/AN/AAC/ANC/AFA	2	1.73	2.00	2.23	2.50	2.74	2.95	1.69	1.95	2.18	2.44	2.67	2.89	1.62	1.87	2.09	2.34	2.56	2.77
AA/AN/AAC/ANC/AFA	2-1/2	2.05	2.37	2.65	2.96	3.24	3.50	2.01	2.32	2.59	2.90	3.18	3.43	1.92	2.22	2.48	2.77	3.04	3.28
AA/AN/AAC/ANC/AFA	3	2.81	3.24	3.63	4.06	4.44	4.80	2.75	3.18	3.55	3.97	4.35	4.70	2.62	3.03	3.38	3.78	4.14	4.47
TCLE	1/4	0.26	0.30	0.34	0.38	0.41	0.44	0.25	0.29	0.32	0.36	0.40	0.43	0.24	0.28	0.31	0.35	0.38	0.41
TCLE	1/2	0.48	0.55	0.62	0.69	0.76	0.82	0.47	0.54	0.61	0.68	0.74	0.80	0.45	0.52	0.58	0.65	0.71	0.77
TCLE	1	0.97	1.12	1.25	1.40	1.53	1.66	0.95	1.10	1.23	1.37	1.50	1.62	0.91	1.05	1.17	1.31	1.44	1.55
TCLE	2	1.80	2.08	2.32	2.60	2.85	3.07	1.76	2.03	2.27	2.54	2.78	3.01	1.68	1.94	2.17	2.42	2.66	2.87
TCLE	3	2.62	3.03	3.38	3.78	4.14	4.47	2.56	2.96	3.30	3.70	4.05	4.37	2.44	2.82	3.15	3.52	3.86	4.17
TCLE	4-1/2	3.80	4.39	4.91	5.48	6.01	6.49	3.72	4.30	4.80	5.37	5.88	6.35	3.55	4.10	4.58	5.12	5.61	6.06
TCLE	7	5.23	6.04	6.75	7.55	8.27	8.93	5.12	5.91	6.61	7.39	8.10	8.74	4.89	5.65	6.31	7.06	7.73	8.35
TCLE	8	6.31	7.29	8.15	9.11	9.98	10.78	6.18	7.14	7.98	8.92	9.77	10.55	5.90	6.81	7.62	8.52	9.33	10.08
TJL	7	5.59	6.45	7.22	8.07	8.84	9.55	5.47	6.32	7.06	7.90	8.65	9.34	5.22	6.03	6.74	7.53	8.25	8.91
TJL	9	7.13	8.23	9.20	10.29	11.27	12.18	6.98	8.06	9.01	10.07	11.04	11.92	6.66	7.69	8.60	9.61	10.53	11.37

Note: Standard capacity is rated at 100F liquid inlet and 40F evaporator temperature; with 100 Psi pressure drop across the TXV per ARI 750-2001.

Valve Type	Nominal Rating	Evaporator Temperature																	
		0°F				-20°F				-40°F									
		Pressure Drop Across Valve (PSI)				Pressure Drop Across Valve (PSI)				Pressure Drop Across Valve (PSI)									
	60	80	100	125	150	175	80	100	125	150	175	200	80	100	125	150	175	200	
AA/AN/AAC/ANC/AFA	1/8	0.15	0.17	0.19	0.22	0.24	0.26	0.11	0.12	0.14	0.15	0.16	0.17	0.07	0.08	0.09	0.10	0.10	0.11
AA/AN/AAC/ANC/AFA	1/4	0.26	0.30	0.34	0.38	0.41	0.44	0.20	0.22	0.25	0.27	0.30	0.32	0.13	0.15	0.16	0.18	0.19	0.21
AA/AN/AAC/ANC/AFA	1/2	0.41	0.47	0.53	0.59	0.65	0.70	0.32	0.36	0.40	0.44	0.47	0.51	0.21	0.23	0.26	0.29	0.31	0.33
AA/AN/AAC/ANC/AFA	1	0.59	0.68	0.76	0.85	0.93	1.01	0.46	0.51	0.58	0.63	0.68	0.73	0.29	0.32	0.36	0.40	0.43	0.46
AA/AN/AAC/ANC/AFA	1-1/2	1.21	1.40	1.56	1.75	1.91	2.07	0.96	1.07	1.20	1.31	1.42	1.52	0.61	0.68	0.76	0.84	0.90	0.96
AA/AN/AAC/ANC/AFA	2	1.49	1.72	1.92	2.15	2.36	2.54	1.17	1.31	1.46	1.60	1.73	1.85	0.75	0.84	0.94	1.03	1.11	1.19
AA/AN/AAC/ANC/AFA	2-1/2	1.76	2.03	2.27	2.54	2.78	3.01	1.39	1.55	1.74	1.90	2.06	2.20	0.89	1.00	1.11	1.22	1.32	1.41
AA/AN/AAC/ANC/AFA	3	2.41	2.78	3.11	3.48	3.81	4.12	1.90	2.12	2.38	2.60	2.81	3.00	1.21	1.35	1.51	1.66	1.79	1.91
TCLE	1/4	0.22	0.25	0.28	0.32	0.35	0.38	0.17	0.19	0.21	0.23	0.25	0.27	0.11	0.12	0.14	0.15	0.16	0.17
TCLE	1/2	0.41	0.47	0.53	0.59	0.65	0.70	0.33	0.37	0.41	0.45	0.49	0.52	0.21	0.23	0.26	0.29	0.31	0.33
TCLE	1	0.84	0.97	1.08	1.21	1.33	1.43	0.66	0.74	0.83	0.90	0.98	1.04	0.42	0.47	0.53	0.58	0.62	0.66
TCLE	2	1.54	1.78	1.99	2.22	2.43	2.63	1.22	1.36	1.53	1.67	1.80	1.93	0.78	0.87	0.98	1.07	1.15	1.23
TCLE	3	2.25	2.60	2.90	3.25	3.56	3.84	1.78	1.99	2.23	2.44	2.63	2.81	1.13	1.26	1.41	1.55	1.67	1.79
TCLE	4-1/2	3.26	3.76	4.21	4.71	5.15	5.57	2.58	2.88	3.23	3.53	3.82	4.08	1.64	1.83	2.05	2.25	2.43	2.59
TCLE	7	4.50	5.20	5.81	6.50	7.12	7.69	3.55	3.97	4.44	4.86	5.25	5.61	2.26	2.53	2.83	3.09	3.34	3.57
TCLE	8	5.42	6.26	7.00	7.82	8.57	9.26	4.28	4.79	5.35	5.86	6.33	6.77	2.73	3.05	3.41	3.74	4.04	4.32
TJL	7	4.81	5.55	6.21	6.94	7.61	8.21	3.80	4.25	4.75	5.20	5.62	6.01	2.42	2.71	3.03	3.31	3.58	3.83
TJL	9	6.13	7.08	7.91	8.85	9.69	10.47	4.84	5.41	6.05	6.63	7.16	7.65	3.08	3.44	3.85	4.22	4.56	4.87

Refrigerant Liquid Temperature Valve Capacity Multiplier Correction Factors

	Refrigerant Liquid Temperature °F														
	0	10	20	30	40	50	60	70	80	90	100	110	120	130	140
R-12 Correction Factor	1.60	1.54	1.48	1.42	1.36	1.30	1.24	1.18	1.12	1.06	1.00	.94	.88	.82	.75
R-134a Correction Factor	1.70	1.63	1.56	1.49	1.42	1.36	1.29	1.21	1.14	1.07	1.00	.93	.85	.78	.71
R-22 Correction Factor	1.56	1.51	1.45	1.40	1.34	1.29	1.23	1.17	1.12	1.06	1.00	.94	.88	.82	.76
R-404A/R-507 Correction Factor	2.00	1.90	1.80	1.70	1.60	1.50	1.40	1.30	1.20	1.10	1.00	.90	.80	.70	.50

These factors include corrections for liquid refrigerant density and net refrigerating effect and are based on an average evaporator temperature of 0°F. However, they may be used for any evaporator temperature from -40°F to +40°F since the variation in the actual factors across this range is insignificant.

R-12 Balanced Ported Valves (Tons)– HF, TRAE and T Series

Valve Type	Nominal Rating	Evaporator Temperature																	
		50°F					40°F					20°F							
		Pressure Drop Across Valve (PSI)					Pressure Drop Across Valve (PSI)					Pressure Drop Across Valve (PSI)							
	60	80	100	125	150	175	60	80	100	125	150	175	60	80	100	125	150	175	
HF	1/8	0.17	0.20	0.22	0.25	0.27	0.29	0.17	0.20	0.22	0.25	0.27	0.29	0.16	0.18	0.21	0.23	0.25	0.27
HF	1/4	0.32	0.37	0.41	0.46	0.51	0.55	0.31	0.36	0.40	0.45	0.49	0.53	0.30	0.35	0.39	0.43	0.47	0.51
HF	1/2	0.57	0.66	0.74	0.82	0.90	0.97	0.56	0.65	0.72	0.81	0.89	0.96	0.54	0.62	0.70	0.78	0.85	0.92
HF	1	0.88	1.02	1.14	1.27	1.39	1.50	0.86	0.99	1.11	1.24	1.36	1.47	0.82	0.95	1.06	1.18	1.30	1.40
HF	1-1/4	1.18	1.36	1.52	1.70	1.87	2.02	1.16	1.34	1.50	1.67	1.83	1.98	1.11	1.28	1.43	1.60	1.76	1.90
HF	1-1/2	1.51	1.74	1.95	2.18	2.39	2.58	1.48	1.71	1.91	2.14	2.34	2.53	1.42	1.64	1.83	2.05	2.25	2.43
HF	2	2.00	2.31	2.58	2.89	3.16	3.42	1.96	2.26	2.53	2.83	3.10	3.35	1.88	2.17	2.43	2.71	2.97	3.21
HF	3-1/2	3.55	4.10	4.58	5.12	5.61	6.06	3.48	4.02	4.49	5.02	5.50	5.94	3.34	3.86	4.31	4.82	5.28	5.70
HF	5	4.94	5.70	6.38	7.13	7.81	8.44	4.85	5.60	6.26	7.00	7.67	8.28	4.65	5.37	6.00	6.71	7.35	7.94
HF	6	6.26	7.23	8.08	9.04	9.90	10.69	6.13	7.08	7.91	8.85	9.69	10.47	5.88	6.79	7.59	8.49	9.30	10.04
HF	9	9.28	10.72	11.98	13.39	14.67	15.85	9.10	10.51	11.75	13.13	14.39	15.54	8.73	10.08	11.27	12.60	13.80	14.91
HF	12	12.22	14.11	15.78	17.64	19.32	20.87	11.98	13.83	15.47	17.29	18.94	20.46	11.49	13.27	14.83	16.58	18.17	19.62
TRAE+	7-1/2	7.14	8.24	9.22	10.31	11.29	12.19	7.00	8.08	9.04	10.10	11.07	11.95	6.71	7.75	8.66	9.69	10.61	11.46
TRAE+	10	10.41	12.02	13.44	15.03	16.46	17.78	10.20	11.78	13.17	14.72	16.13	17.42	9.78	11.29	12.63	14.12	15.46	16.70
TRAE+	12	11.62	13.42	15.00	16.77	18.37	19.84	11.39	13.15	14.70	16.44	18.01	19.45	10.92	12.61	14.10	15.76	17.27	18.65
TRAE+	18	17.61	20.33	22.73	25.42	27.84	30.07	17.26	19.93	22.28	24.91	27.29	29.48	16.55	19.11	21.37	23.89	26.17	28.26
TRAE+	25	24.20	27.94	31.24	34.93	38.26	41.33	23.73	27.40	30.64	34.25	37.52	40.53	22.75	26.27	29.37	32.84	35.97	38.85
TRAE	30	32.67	37.72	42.18	47.16	51.66	55.79	32.03	36.99	41.35	46.23	50.64	54.70	30.72	35.47	39.66	44.34	48.57	52.46
TRAE	35	35.64	41.15	46.01	51.44	56.35	60.87	34.94	40.35	45.11	50.43	55.24	59.67	33.51	38.69	43.26	48.37	52.98	57.23
TRAE	40	42.41	48.97	54.75	61.21	67.06	72.43	41.58	48.01	53.68	60.02	65.74	71.01	39.88	46.05	51.48	57.56	63.06	68.11
TJR	8	8.89	10.27	11.48	12.83	14.06	15.18	8.72	10.07	11.26	12.59	13.79	14.89	8.36	9.65	10.79	12.07	13.22	14.28
TJR	11	10.65	12.30	13.75	15.37	16.84	18.19	10.44	12.06	13.48	15.07	16.51	17.83	10.01	11.56	12.92	14.45	15.83	17.10
TER	13	13.31	15.37	17.18	19.21	21.04	22.73	13.05	15.07	16.85	18.84	20.63	22.29	12.51	14.45	16.15	18.06	19.78	21.36
TER	15	15.73	18.16	20.31	22.70	24.87	26.86	15.42	17.81	19.91	22.26	24.38	26.33	14.79	17.08	19.09	21.35	23.39	25.26
TER	20	21.18	24.46	27.34	30.57	33.49	36.17	20.76	23.97	26.80	29.96	32.82	35.45	19.91	22.99	25.70	28.74	31.48	34.00
TER	25	27.23	31.44	35.15	39.30	43.05	46.50	26.69	30.82	34.46	38.52	42.20	45.58	25.60	29.56	33.05	36.95	40.48	43.72
TIR	35	31.29	36.13	40.40	45.16	49.47	53.44	23.63	27.29	30.51	34.11	37.36	40.36	31.29	36.13	40.40	45.16	49.47	53.44
THR	45	42.35	48.90	54.67	61.13	66.96	72.33	41.52	47.94	53.60	59.93	65.65	70.91	39.82	45.98	51.41	57.48	62.96	68.01
THR	55	51.43	59.39	66.40	74.23	81.32	87.83	50.42	58.22	65.09	72.78	79.72	86.11	48.35	55.83	62.42	69.79	76.45	82.57
TMR	55	60.50	69.86	78.11	87.32	95.66	103.32	59.32	68.50	76.58	85.62	93.79	101.31	56.89	65.69	73.44	82.11	89.95	97.16

Note: Standard capacity is rated at 100F liquid inlet and 40F evaporator temperature; with 60 Psi pressure drop across the TXV per ARI 750-2001.

Refrigerant Liquid Temperature Valve Capacity Multiplier Correction Factors

	Refrigerant Liquid Temperature °F															
	0	10	20	30	40	50	60	70	80	90	100	110	120	130	140	
R-12 Correction Factor	1.60	1.54	1.48	1.42	1.36	1.30	1.24	1.18	1.12	1.06	1.00	.94	.88	.82	.75	
R-134a Correction Factor	1.70	1.63	1.56	1.49	1.42	1.36	1.29	1.21	1.14	1.07	1.00	.93	.85	.78	.71	
R-22 Correction Factor	1.56	1.51	1.45	1.40	1.34	1.29	1.23	1.17	1.12	1.06	1.00	.94	.88	.82	.76	
R-404A/R-507 Correction	2.00	1.90	1.80	1.70	1.60	1.50	1.40	1.30	1.20	1.10	1.00	.90	.80	.70	.50	

These factors include corrections for liquid refrigerant density and net refrigerating effect and are based on an average evaporator temperature of 0°F. However, they may be used for any evaporator temperature from -40°F to +40°F since the variation in the actual factors across this range is insignificant.

Thermal Expansion Valves
TXV Extended Capacity Tables
EX Valves and Controls
Solenoid Valves and Coils
Solenoid Capacity Tables
Industrial Solenoid Valves
Shut Off Valves
System Protectors
System Protectors Capacity Tables
Oil Controls
Temperature Pressure Controls

R-12 Balanced Ported Valves (Tons)– HF, TRAE and T Series (cont.)

Valve Type	Nominal Rating	Evaporator Temperature																	
		0°F						-20°F						-40°F					
		Pressure Drop Across Valve (PSI)						Pressure Drop Across Valve (PSI)						Pressure Drop Across Valve (PSI)					
		60	80	100	125	150	175	80	100	125	150	175	200	80	100	125	150	175	200
HF	1/8	0.14	0.16	0.18	0.20	0.22	0.24	0.11	0.12	0.14	0.15	0.16	0.17	0.07	0.08	0.09	0.10	0.10	0.11
HF	1/4	0.27	0.31	0.35	0.39	0.43	0.46	0.21	0.23	0.26	0.29	0.31	0.33	0.14	0.16	0.18	0.19	0.21	0.22
HF	1/2	0.48	0.55	0.62	0.69	0.76	0.82	0.38	0.42	0.48	0.52	0.56	0.60	0.24	0.27	0.30	0.33	0.35	0.38
HF	1	0.73	0.84	0.94	1.05	1.15	1.25	0.57	0.64	0.71	0.78	0.84	0.90	0.37	0.41	0.46	0.51	0.55	0.59
HF	1-1/4	0.98	1.13	1.27	1.41	1.55	1.67	0.77	0.86	0.96	1.05	1.14	1.22	0.50	0.56	0.63	0.68	0.74	0.79
HF	1-1/2	1.26	1.45	1.63	1.82	1.99	2.15	0.99	1.11	1.24	1.36	1.46	1.57	0.64	0.72	0.80	0.88	0.95	1.01
HF	2	1.66	1.92	2.14	2.40	2.62	2.83	1.30	1.45	1.63	1.78	1.92	2.06	0.85	0.95	1.06	1.16	1.26	1.34
HF	3-1/2	2.96	3.42	3.82	4.27	4.68	5.06	2.32	2.59	2.90	3.18	3.43	3.67	1.51	1.69	1.89	2.07	2.23	2.39
HF	5	4.12	4.76	5.32	5.95	6.51	7.04	3.23	3.61	4.04	4.42	4.78	5.11	2.10	2.35	2.63	2.88	3.11	3.32
HF	6	5.21	6.02	6.73	7.52	8.24	8.90	4.08	4.56	5.10	5.59	6.03	6.45	2.66	2.97	3.33	3.64	3.93	4.21
HF	9	7.73	8.93	9.98	11.16	12.22	13.20	6.06	6.78	7.58	8.30	8.96	9.58	3.94	4.41	4.93	5.40	5.83	6.23
HF	12	10.17	11.74	13.13	14.68	16.08	17.37	7.97	8.91	9.96	10.91	11.79	12.60	5.18	5.79	6.48	7.09	7.66	8.19
TRAE+	7-1/2	5.95	6.87	7.68	8.59	9.41	10.16	4.66	5.21	5.83	6.38	6.89	7.37	3.03	3.39	3.79	4.15	4.48	4.79
TRAE+	10	8.67	10.01	11.19	12.51	13.71	14.81	6.79	7.59	8.49	9.30	10.04	10.74	4.42	4.94	5.53	6.05	6.54	6.99
TRAE+	12	9.67	11.17	12.48	13.96	15.29	16.51	7.58	8.47	9.48	10.38	11.21	11.99	4.93	5.51	6.16	6.75	7.29	7.80
TRAE+	18	14.66	16.93	18.93	21.16	23.18	25.04	11.49	12.85	14.36	15.73	16.99	18.17	7.47	8.35	9.34	10.23	11.05	11.81
TRAE+	25	20.15	23.27	26.01	29.08	31.86	34.41	15.80	17.66	19.75	21.64	23.37	24.98	10.27	11.48	12.84	14.06	15.19	16.24
TRAE	30	27.21	31.42	35.13	39.27	43.02	46.47	21.33	23.85	26.66	29.21	31.55	33.73	13.87	15.51	17.34	18.99	20.51	21.93
TRAE	35	29.68	34.27	38.32	42.84	46.93	50.69	23.26	26.01	29.08	31.85	34.40	36.78	15.13	16.92	18.91	20.72	22.38	23.92
TRAE	40	35.32	40.78	45.60	50.98	55.85	60.32	27.68	30.95	34.60	37.90	40.94	43.77	18.00	20.12	22.50	24.65	26.62	28.46
TJR	8	7.41	8.56	9.57	10.70	11.72	12.65	5.81	6.50	7.26	7.96	8.59	9.19	3.77	4.21	4.71	5.16	5.58	5.96
TJR	11	8.87	10.24	11.45	12.80	14.02	15.15	6.95	7.77	8.69	9.52	10.28	10.99	4.52	5.05	5.65	6.19	6.69	7.15
TER	13	11.08	12.79	14.30	15.99	17.52	18.92	8.69	9.72	10.86	11.90	12.85	13.74	5.65	6.32	7.06	7.74	8.36	8.93
TER	15	13.10	15.13	16.91	18.91	20.71	22.37	10.27	11.48	12.84	14.06	15.19	16.24	6.68	7.47	8.35	9.15	9.88	10.56
TER	20	17.64	20.37	22.77	25.46	27.89	30.13	13.82	15.45	17.28	18.92	20.44	21.85	8.99	10.05	11.24	12.31	13.30	14.21
TER	25	22.67	26.18	29.27	32.72	35.84	38.72	17.77	19.87	22.21	24.33	26.28	28.10	11.56	12.92	14.45	15.83	17.10	18.28
TIR	35	27.71	32.00	35.77	40.00	43.81	47.32	21.72	24.28	27.15	29.74	32.12	34.34	14.12	15.79	17.65	19.33	20.88	22.33
THR	45	35.27	40.73	45.53	50.91	55.77	60.23	27.64	30.90	34.55	37.85	40.88	43.70	17.98	20.10	22.48	24.62	26.59	28.43
THR	55	42.83	49.46	55.29	61.82	67.72	73.15	33.57	37.53	41.96	45.97	49.65	53.08	21.83	24.41	27.29	29.89	32.29	34.52
TMR	55	50.39	58.19	65.05	72.73	79.67	86.06	39.49	44.15	49.36	54.07	58.41	62.44	25.68	28.71	32.10	35.16	37.98	40.60

Refrigerant Liquid Temperature Valve Capacity Multiplier Correction Factors

	Refrigerant Liquid Temperature °F															
	0	10	20	30	40	50	60	70	80	90	100	110	120	130	140	
R-12 Correction Factor	1.60	1.54	1.48	1.42	1.36	1.30	1.24	1.18	1.12	1.06	1.00	.94	.88	.82	.75	
R-134a Correction Factor	1.70	1.63	1.56	1.49	1.42	1.36	1.29	1.21	1.14	1.07	1.00	.93	.85	.78	.71	
R-22 Correction Factor	1.56	1.51	1.45	1.40	1.34	1.29	1.23	1.17	1.12	1.06	1.00	.94	.88	.82	.76	
R-404A/R-507 Correction Factor	2.00	1.90	1.80	1.70	1.60	1.50	1.40	1.30	1.20	1.10	1.00	.90	.80	.70	.50	

These factors include corrections for liquid refrigerant density and net refrigerating effect and are based on an average evaporator temperature of 0°F. However, they may be used for any evaporator temperature from -40°F to +40°F since the variation in the actual factors across this range is insignificant.

R-22 Balanced Ported Valves (Tons)– HF, TFE, TRAE and T Series

Valve Type	Nominal Rating	Evaporator Temperature																	
		50°F					40°F					20°F							
		Pressure Drop Across Valve (PSI)					Pressure Drop Across Valve (PSI)					Pressure Drop Across Valve (PSI)							
	60	80	100	125	150	175	60	80	100	125	150	175	60	80	100	125	150	175	
HF	1/4	0.22	0.25	0.28	0.32	0.35	0.38	0.22	0.25	0.28	0.31	0.34	0.37	0.21	0.24	0.27	0.30	0.33	0.36
HF	1/2	0.42	0.48	0.54	0.61	0.66	0.72	0.41	0.47	0.53	0.59	0.65	0.70	0.40	0.46	0.52	0.58	0.63	0.68
HF	1	0.75	0.87	0.97	1.08	1.19	1.28	0.74	0.85	0.95	1.06	1.16	1.26	0.72	0.83	0.93	1.04	1.14	1.23
HF	1-1/2	1.14	1.32	1.47	1.65	1.80	1.95	1.12	1.30	1.45	1.62	1.78	1.92	1.10	1.27	1.42	1.59	1.74	1.88
HF	2	1.53	1.77	1.98	2.21	2.42	2.61	1.52	1.75	1.96	2.19	2.40	2.59	1.48	1.71	1.91	2.14	2.34	2.53
HF	2-1/2	1.96	2.26	2.53	2.83	3.10	3.35	1.94	2.25	2.51	2.81	3.07	3.32	1.89	2.18	2.44	2.73	2.99	3.23
HF	3	2.59	2.99	3.34	3.74	4.10	4.42	2.56	2.96	3.31	3.70	4.05	4.38	2.50	2.89	3.23	3.61	3.95	4.27
HF	5-1/2	4.61	5.32	5.95	6.65	7.29	7.87	4.56	5.27	5.89	6.59	7.21	7.79	4.44	5.13	5.73	6.41	7.02	7.58
HF	8	6.42	7.41	8.29	9.27	10.15	10.96	6.34	7.33	8.19	9.16	10.03	10.83	6.18	7.14	7.98	8.92	9.77	10.55
HF	10	8.13	9.39	10.50	11.73	12.85	13.88	8.06	9.30	10.40	11.63	12.74	13.76	7.83	9.04	10.11	11.30	12.38	13.37
HF	15	12.05	13.91	15.56	17.39	19.05	20.58	11.91	13.77	15.40	17.22	18.86	20.37	11.61	13.41	14.99	16.76	18.36	19.83
HF	20	15.87	18.33	20.49	22.91	25.09	27.10	15.68	18.07	20.20	22.58	24.74	26.72	15.28	17.64	19.73	22.05	24.16	26.10
TFE	8	6.30	7.27	8.13	9.09	9.96	10.76	6.23	7.19	8.04	8.99	9.85	10.64	6.07	7.01	7.84	8.76	9.60	10.37
TFE	10	8.63	9.97	11.14	12.46	13.65	14.74	8.53	9.85	11.01	12.31	13.48	14.56	8.31	9.60	10.73	11.99	13.14	14.19
TFE	12	10.71	12.37	13.83	15.46	16.93	18.29	10.59	12.23	13.67	15.28	16.74	18.08	10.32	11.92	13.32	14.90	16.32	17.62
TFE	20	16.35	18.88	21.11	23.60	25.85	27.92	16.17	18.67	20.87	23.33	25.56	27.61	15.75	18.19	20.33	22.73	24.90	26.90
TRAE+	10	9.27	10.70	11.97	13.38	14.66	15.83	9.16	10.58	11.83	13.23	14.49	15.65	8.93	10.31	11.53	12.89	14.12	15.25
TRAE+	15	13.52	15.61	17.45	19.51	21.38	23.09	13.36	15.43	17.25	19.29	21.13	22.82	13.02	15.03	16.81	18.79	20.59	22.24
TRAE+	20	15.09	17.42	19.48	21.78	23.86	25.77	14.91	17.22	19.25	21.52	23.58	25.47	14.53	16.78	18.76	20.97	22.97	24.81
TRAE+	30	22.87	26.41	29.53	33.01	36.16	39.06	22.60	26.10	29.18	32.62	35.74	38.60	22.02	25.43	28.43	31.78	34.82	37.61
TRAE+	40	31.43	36.29	40.58	45.37	49.70	53.68	31.07	35.88	40.11	44.84	49.12	53.06	30.27	34.95	39.08	43.69	47.86	51.70
TRAE	50	42.43	48.99	54.78	61.24	67.09	72.46	41.94	48.42	54.14	60.53	66.31	71.62	40.87	47.19	52.76	58.99	64.62	69.80
TRAE	60	46.28	53.44	59.75	66.80	73.18	79.04	45.75	52.82	59.06	66.03	72.33	78.13	44.58	51.48	57.55	64.35	70.49	76.13
TRAE	70	55.09	63.61	71.12	79.52	87.10	94.08	54.45	62.87	70.29	78.59	86.09	92.98	53.06	61.27	68.50	76.59	83.90	90.62
TJR	14	11.55	13.34	14.91	16.67	18.26	19.73	11.42	13.18	14.74	16.48	18.05	19.50	11.13	12.85	14.37	16.06	17.60	19.01
TJR	18	13.83	15.97	17.85	19.96	21.87	23.62	13.67	15.79	17.65	19.73	21.62	23.35	13.32	15.38	17.20	19.23	21.06	22.75
TER	22	17.29	19.96	22.32	24.96	27.34	29.53	17.09	19.73	22.06	24.66	27.02	29.18	16.65	19.23	21.50	24.03	26.33	28.44
TER	26	20.43	23.59	26.38	29.49	32.30	34.89	20.19	23.32	26.07	29.15	31.93	34.49	19.68	22.72	25.41	28.41	31.12	33.61
TER	35	27.50	31.75	35.50	39.69	43.48	46.97	27.18	31.39	35.09	39.23	42.98	46.42	26.49	30.59	34.20	38.24	41.88	45.24
TER	45	35.36	40.83	45.65	51.04	55.91	60.39	34.95	40.36	45.12	50.45	55.26	59.69	34.06	39.33	43.97	49.16	53.85	58.17
TIR	55	43.22	49.91	55.80	62.38	68.34	73.81	42.72	49.33	55.15	61.66	67.54	72.96	41.63	48.07	53.74	60.09	65.82	71.10
THR	75	55.01	63.52	71.02	79.40	86.98	93.95	54.37	62.78	70.19	78.47	85.96	92.85	52.98	61.18	68.40	76.47	83.77	90.48
THR	85	66.79	77.12	86.23	96.40	105.60	114.07	66.02	76.23	85.23	95.29	104.39	112.75	64.33	74.28	83.05	92.85	101.71	109.86
TMR	100	78.58	90.74	101.45	113.42	124.25	134.20	77.67	89.68	100.27	112.11	122.81	132.64	75.69	87.40	97.72	109.25	119.68	129.27

Note: Standard capacity is rated at 100F liquid inlet and 40F evaporator temperature; with 100 Psi pressure drop across the TXV per ARI 750-2001.

Refrigerant Liquid Temperature Valve Capacity Multiplier Correction Factors

	Refrigerant Liquid Temperature °F														
	0	10	20	30	40	50	60	70	80	90	100	110	120	130	140
R-12 Correction Factor	1.60	1.54	1.48	1.42	1.36	1.30	1.24	1.18	1.12	1.06	1.00	.94	.88	.82	.75
R-134a Correction Factor	1.70	1.63	1.56	1.49	1.42	1.36	1.29	1.21	1.14	1.07	1.00	.93	.85	.78	.71
R-22 Correction Factor	1.56	1.51	1.45	1.40	1.34	1.29	1.23	1.17	1.12	1.06	1.00	.94	.88	.82	.76
R-404A/R-507 Correction Factor	2.00	1.90	1.80	1.70	1.60	1.50	1.40	1.30	1.20	1.10	1.00	.90	.80	.70	.50

These factors include corrections for liquid refrigerant density and net refrigerating effect and are based on an average evaporator temperature of 0°F. However, they may be used for any evaporator temperature from -40°F to +40°F since the variation in the actual factors across this range is insignificant.

R-22 Balanced Ported Valves (Tons)– HF, TFE, TRAE and T Series (cont.)

Valve Type	Nominal Rating	Evaporator Temperature																	
		0°F					-20°F					-40°F							
		Pressure Drop Across Valve (PSI)					Pressure Drop Across Valve (PSI)					Pressure Drop Across Valve (PSI)							
		60	80	100	125	150	175	80	100	125	150	175	200	80	100	125	150	175	200
HF	1/4	0.19	0.22	0.25	0.27	0.30	0.32	0.15	0.17	0.19	0.21	0.22	0.24	0.10	0.11	0.13	0.14	0.15	0.16
HF	1/2	0.36	0.42	0.46	0.52	0.57	0.61	0.29	0.32	0.36	0.40	0.43	0.46	0.19	0.21	0.24	0.26	0.28	0.30
HF	1	0.65	0.75	0.84	0.94	1.03	1.11	0.52	0.58	0.65	0.71	0.77	0.82	0.34	0.38	0.43	0.47	0.50	0.54
HF	1-1/2	1.00	1.15	1.29	1.44	1.58	1.71	0.79	0.88	0.99	1.08	1.17	1.25	0.52	0.58	0.65	0.71	0.77	0.82
HF	2	1.34	1.55	1.73	1.93	2.12	2.29	1.07	1.20	1.34	1.47	1.58	1.69	0.70	0.78	0.88	0.96	1.04	1.11
HF	2-1/2	1.72	1.99	2.22	2.48	2.72	2.94	1.37	1.53	1.71	1.88	2.03	2.17	0.90	1.01	1.13	1.23	1.33	1.42
HF	3	2.26	2.61	2.92	3.26	3.57	3.86	1.81	2.02	2.26	2.48	2.68	2.86	1.19	1.33	1.49	1.63	1.76	1.88
HF	5-1/2	4.03	4.65	5.20	5.82	6.37	6.88	3.22	3.60	4.03	4.41	4.76	5.09	2.12	2.37	2.65	2.90	3.14	3.35
HF	8	5.61	6.48	7.24	8.10	8.87	9.58	4.48	5.01	5.60	6.13	6.63	7.08	2.95	3.30	3.69	4.04	4.36	4.66
HF	10	7.10	8.20	9.17	10.25	11.23	12.13	5.67	6.34	7.09	7.76	8.39	8.97	3.73	4.17	4.66	5.11	5.52	5.90
HF	15	10.53	12.16	13.59	15.20	16.65	17.98	8.40	9.39	10.50	11.50	12.42	13.28	5.53	6.18	6.91	7.57	8.18	8.74
HF	20	13.86	16.00	17.89	20.01	21.91	23.67	11.06	12.37	13.83	15.14	16.36	17.49	7.28	8.14	9.10	9.97	10.77	11.51
TFE	8	5.50	6.35	7.10	7.94	8.70	9.39	4.39	4.91	5.49	6.01	6.49	6.94	2.89	3.23	3.61	3.96	4.27	4.57
TFE	10	7.54	8.71	9.73	10.88	11.92	12.88	6.02	6.73	7.53	8.24	8.90	9.52	3.96	4.43	4.95	5.42	5.86	6.26
TFE	12	9.35	10.80	12.07	13.50	14.78	15.97	7.47	8.35	9.34	10.23	11.05	11.81	4.92	5.50	6.15	6.74	7.28	7.78
TFE	20	14.28	16.49	18.44	20.61	22.58	24.39	11.40	12.75	14.25	15.61	16.86	18.02	7.51	8.40	9.39	10.28	11.11	11.87
TRAE+	10	8.10	9.35	10.46	11.69	12.81	13.83	6.47	7.23	8.09	8.86	9.57	10.23	4.26	4.76	5.33	5.83	6.30	6.74
TRAE+	15	11.80	13.63	15.23	17.03	18.66	20.15	9.42	10.53	11.78	12.90	13.93	14.89	6.21	6.94	7.76	8.50	9.18	9.82
TRAE+	20	13.18	15.22	17.02	19.02	20.84	22.51	10.52	11.76	13.15	14.41	15.56	16.63	6.93	7.75	8.66	9.49	10.25	10.96
TRAE+	30	19.97	23.06	25.78	28.82	31.58	34.11	15.94	17.82	19.93	21.83	23.58	25.20	10.50	11.74	13.13	14.38	15.53	16.60
TRAE+	40	27.45	31.70	35.44	39.62	43.40	46.88	21.92	24.51	27.40	30.02	32.42	34.66	14.43	16.13	18.04	19.76	21.34	22.82
TRAE+	50	37.06	42.79	47.84	53.49	58.60	63.29	29.59	33.08	36.99	40.52	43.76	46.79	19.48	21.78	24.35	26.67	28.81	30.80
TRAE	60	40.42	46.67	52.18	58.34	63.91	69.03	32.27	36.08	40.34	44.19	47.73	51.02	21.25	23.76	26.56	29.10	31.43	33.60
TRAE	70	48.11	55.55	62.11	69.44	76.07	82.16	38.41	42.94	48.01	52.60	56.81	60.73	25.29	28.28	31.61	34.63	37.40	39.99
TJR	14	10.09	11.65	13.03	14.56	15.95	17.23	8.05	9.00	10.06	11.02	11.91	12.73	5.30	5.93	6.63	7.26	7.84	8.38
TJR	18	12.08	13.95	15.60	17.44	19.10	20.63	9.64	10.78	12.05	13.20	14.26	15.24	6.35	7.10	7.94	8.70	9.39	10.04
TER	22	15.10	17.44	19.49	21.79	23.88	25.79	12.05	13.47	15.06	16.50	17.82	19.05	7.94	8.88	9.93	10.87	11.74	12.55
TER	26	17.84	20.60	23.03	25.75	28.21	30.47	14.25	15.93	17.81	19.51	21.08	22.53	9.38	10.49	11.73	12.84	13.87	14.83
TER	35	24.02	27.74	31.01	34.67	37.98	41.02	19.18	21.44	23.98	26.26	28.37	30.33	12.63	14.12	15.79	17.29	18.68	19.97
TER	45	30.88	35.66	39.87	44.57	48.83	52.74	24.66	27.57	30.83	33.77	36.47	38.99	16.24	18.16	20.30	22.24	24.02	25.68
TIR	55	37.75	43.59	48.74	54.49	59.69	64.47	30.13	33.69	37.66	41.26	44.56	47.64	19.84	22.18	24.80	27.17	29.34	31.37
THR	75	48.04	55.47	62.02	69.34	75.96	82.04	38.35	42.88	47.94	52.51	56.72	60.64	25.26	28.24	31.58	34.59	37.36	39.94
THR	85	58.33	67.35	75.30	84.19	92.23	99.62	46.57	52.07	58.21	63.77	68.88	73.63	30.67	34.29	38.34	42.00	45.36	48.49
TMR	100	68.63	79.25	88.60	99.06	108.51	117.21	54.79	61.26	68.49	75.02	81.04	86.63	36.08	40.34	45.10	49.40	53.36	57.05

Refrigerant Liquid Temperature Valve Capacity Multiplier Correction Factors

	Refrigerant Liquid Temperature °F														
	0	10	20	30	40	50	60	70	80	90	100	110	120	130	140
R-12 Correction Factor	1.60	1.54	1.48	1.42	1.36	1.30	1.24	1.18	1.12	1.06	1.00	.94	.88	.82	.75
R-134a Correction Factor	1.70	1.63	1.56	1.49	1.42	1.36	1.29	1.21	1.14	1.07	1.00	.93	.85	.78	.71
R-22 Correction Factor	1.56	1.51	1.45	1.40	1.34	1.29	1.23	1.17	1.12	1.06	1.00	.94	.88	.82	.76
R-404A/R-507 Correction Factor	2.00	1.90	1.80	1.70	1.60	1.50	1.40	1.30	1.20	1.10	1.00	.90	.80	.70	.50

These factors include corrections for liquid refrigerant density and net refrigerating effect and are based on an average evaporator temperature of 0°F. However, they may be used for any evaporator temperature from -40°F to +40°F since the variation in the actual factors across this range is insignificant.

R-134a Balanced Ported Valves (Tons)– HF, TFE, TRAE and T Series

Valve Type	Nominal Rating	Evaporator Temperature																	
		50°F						40°F					20°F						
		Pressure Drop Across Valve (PSI)						Pressure Drop Across Valve (PSI)					Pressure Drop Across Valve (PSI)						
	60	80	100	125	150	175	60	80	100	125	150	175	60	80	100	125	150	175	
HF	1/4	0.21	0.24	0.27	0.30	0.33	0.36	0.21	0.24	0.27	0.30	0.33	0.36	0.20	0.23	0.26	0.29	0.32	0.34
HF	1/2	0.40	0.46	0.52	0.58	0.63	0.68	0.39	0.45	0.50	0.56	0.62	0.67	0.37	0.43	0.48	0.53	0.59	0.63
HF	3/4	0.71	0.82	0.92	1.02	1.12	1.21	0.70	0.81	0.90	1.01	1.11	1.20	0.67	0.77	0.86	0.97	1.06	1.14
HF	1	1.09	1.26	1.41	1.57	1.72	1.86	1.06	1.22	1.37	1.53	1.68	1.81	1.02	1.18	1.32	1.47	1.61	1.74
HF	1-1/2	1.46	1.69	1.88	2.11	2.31	2.49	1.43	1.65	1.85	2.06	2.26	2.44	1.37	1.58	1.77	1.98	2.17	2.34
HF	1-3/4	1.87	2.16	2.41	2.70	2.96	3.19	1.84	2.12	2.38	2.66	2.91	3.14	1.76	2.03	2.27	2.54	2.78	3.01
HF	2-1/2	2.47	2.85	3.19	3.57	3.91	4.22	2.42	2.79	3.12	3.49	3.83	4.13	2.32	2.68	3.00	3.35	3.67	3.96
HF	4	4.40	5.08	5.68	6.35	6.96	7.51	4.31	4.98	5.56	6.22	6.81	7.36	4.12	4.76	5.32	5.95	6.51	7.04
HF	6	6.12	7.07	7.90	8.83	9.68	10.45	6.00	6.93	7.75	8.66	9.49	10.25	5.74	6.63	7.41	8.28	9.08	9.80
HF	7-1/2	7.75	8.95	10.01	11.19	12.25	13.24	7.59	8.76	9.80	10.96	12.00	12.96	7.26	8.38	9.37	10.48	11.48	12.40
HF	11	11.50	13.28	14.85	16.60	18.18	19.64	11.26	13.00	14.54	16.25	17.80	19.23	10.77	12.44	13.90	15.55	17.03	18.39
HF	14	15.13	17.47	19.53	21.84	23.92	25.84	14.82	17.11	19.13	21.39	23.43	25.31	14.18	16.37	18.31	20.47	22.42	24.22
TFE	6	6.01	6.94	7.76	8.67	9.50	10.26	5.89	6.80	7.60	8.50	9.31	10.06	5.63	6.50	7.27	8.13	8.90	9.62
TFE	8	8.23	9.50	10.62	11.88	13.01	14.06	8.06	9.31	10.41	11.63	12.74	13.77	7.71	8.90	9.95	11.13	12.19	13.17
TFE	10	10.22	11.80	13.19	14.75	16.16	17.45	10.01	11.56	12.92	14.45	15.83	17.10	9.57	11.05	12.35	13.81	15.13	16.34
TFE	15	15.60	18.01	20.14	22.52	24.67	26.64	15.28	17.64	19.73	22.05	24.16	26.10	14.61	16.87	18.86	21.09	23.10	24.95
TRAE+	9	8.84	10.21	11.41	12.76	13.98	15.10	8.66	10.00	11.18	12.50	13.69	14.79	8.29	9.57	10.70	11.97	13.11	14.16
TRAE+	13	12.89	14.88	16.64	18.61	20.38	22.01	12.63	14.58	16.31	18.23	19.97	21.57	12.08	13.95	15.60	17.44	19.10	20.63
TRAE+	14	14.39	16.62	18.58	20.77	22.75	24.58	14.09	16.27	18.19	20.34	22.28	24.06	13.48	15.57	17.40	19.46	21.31	23.02
TRAE+	22	21.81	25.18	28.16	31.48	34.48	37.25	21.36	24.66	27.58	30.83	33.77	36.48	20.43	23.59	26.38	29.49	32.30	34.89
TRAE+	30	29.98	34.62	38.70	43.27	47.40	51.20	29.36	33.90	37.90	42.38	46.42	50.14	28.09	32.44	36.26	40.54	44.41	47.97
TRAE	40	40.48	46.74	52.26	58.43	64.00	69.13	39.64	45.77	51.18	57.22	62.68	67.70	37.92	43.79	48.95	54.73	59.96	64.76
TRAE	45	44.15	50.98	57.00	63.73	69.81	75.40	43.24	49.93	55.82	62.41	68.37	73.85	41.36	47.76	53.40	59.70	65.40	70.64
TRAE	50	52.54	60.67	67.83	75.83	83.07	89.73	51.46	59.42	66.43	74.28	81.37	87.88	49.22	56.83	63.54	71.04	77.82	84.06
TJR	11	11.02	12.72	14.23	15.91	17.42	18.82	10.79	12.46	13.93	15.57	17.06	18.43	10.32	11.92	13.32	14.90	16.32	17.62
TJR	13	13.19	15.23	17.03	19.04	20.86	22.53	12.92	14.92	16.68	18.65	20.43	22.07	12.36	14.27	15.96	17.84	19.54	21.11
TER	16	16.49	19.04	21.29	23.80	26.07	28.16	16.15	18.65	20.85	23.31	25.54	27.58	15.45	17.84	19.95	22.30	24.43	26.39
TER	19	19.49	22.51	25.16	28.13	30.82	33.29	19.09	22.04	24.65	27.55	30.18	32.60	18.26	21.08	23.57	26.36	28.87	31.18
TER	25	26.23	30.29	33.86	37.86	41.47	44.80	25.69	29.66	33.17	37.08	40.62	43.87	24.58	28.38	31.73	35.48	38.86	41.98
TER	31	33.73	38.95	43.55	48.69	53.33	57.60	33.03	38.14	42.64	47.67	52.23	56.41	31.60	36.49	40.80	45.61	49.96	53.97
TIR	45	41.23	47.61	53.23	59.51	65.19	70.41	40.37	46.62	52.12	58.27	63.83	68.94	38.62	44.59	49.86	55.74	61.06	65.96
THR	55	52.47	60.59	67.74	75.73	82.96	89.61	51.38	59.33	66.33	74.16	81.24	87.75	49.15	56.75	63.45	70.94	77.71	83.94
THR	68	63.71	73.57	82.25	91.96	100.73	108.81	62.40	72.05	80.56	90.07	98.66	106.57	59.69	68.92	77.06	86.16	94.38	101.94
TMR	68	74.95	86.54	96.76	108.18	118.51	128.00	73.41	84.77	94.77	105.96	116.07	125.37	70.22	81.08	90.65	101.35	111.03	119.92

Note: Standard capacity is rated at 100F liquid inlet and 40F evaporator temperature; with 60 Psi pressure drop across the TXV per ARI 750-2001.

Refrigerant Liquid Temperature Valve Capacity Multiplier Correction Factors

	Refrigerant Liquid Temperature °F															
	0	10	20	30	40	50	60	70	80	90	100	110	120	130	140	
R-12 Correction Factor	1.60	1.54	1.48	1.42	1.36	1.30	1.24	1.18	1.12	1.06	1.00	.94	.88	.82	.75	
R-134a Correction Factor	1.70	1.63	1.56	1.49	1.42	1.36	1.29	1.21	1.14	1.07	1.00	.93	.85	.78	.71	
R-22 Correction Factor	1.56	1.51	1.45	1.40	1.34	1.29	1.23	1.17	1.12	1.06	1.00	.94	.88	.82	.76	
R-404A/R-507 Correction Factor	2.00	1.90	1.80	1.70	1.60	1.50	1.40	1.30	1.20	1.10	1.00	.90	.80	.70	.50	

These factors include corrections for liquid refrigerant density and net refrigerating effect and are based on an average evaporator temperature of 0°F. However, they may be used for any evaporator temperature from -40°F to +40°F since the variation in the actual factors across this range is insignificant.

Thermal Expansion Valves
TXV Extended Capacity Tables
EX Valves and Controls
Solenoid Valves and Coils
Solenoid Capacity Tables
Industrial Solenoid Valves
Shut Off Valves
System Protectors
System Protectors Capacity Tables
Oil Controls
Temperature Pressure Controls

R-134a Balanced Ported Valves (Tons)– HF, TFE, TRAE and T Series (cont.)

Valve Type	Nominal Rating	Evaporator Temperature																	
		0°F						-20°F						-40°F					
		Pressure Drop Across Valve (PSI)						Pressure Drop Across Valve (PSI)						Pressure Drop Across Valve (PSI)					
		60	80	100	125	150	175	80	100	125	150	175	200	80	100	125	150	175	200
HF	1/4	0.16	0.18	0.21	0.23	0.25	0.27	0.12	0.13	0.15	0.16	0.18	0.19	0.07	0.08	0.09	0.10	0.10	0.11
HF	1/2	0.31	0.36	0.40	0.45	0.49	0.53	0.23	0.26	0.29	0.31	0.34	0.36	0.14	0.16	0.18	0.19	0.21	0.22
HF	3/4	0.55	0.64	0.71	0.79	0.87	0.94	0.41	0.46	0.51	0.56	0.61	0.65	0.25	0.28	0.31	0.34	0.37	0.40
HF	1	0.84	0.97	1.08	1.21	1.33	1.43	0.63	0.70	0.79	0.86	0.93	1.00	0.38	0.42	0.48	0.52	0.56	0.60
HF	1-1/2	1.13	1.30	1.46	1.63	1.79	1.93	0.84	0.94	1.05	1.15	1.24	1.33	0.52	0.58	0.65	0.71	0.77	0.82
HF	1-3/4	1.44	1.66	1.86	2.08	2.28	2.46	1.08	1.21	1.35	1.48	1.60	1.71	0.66	0.74	0.83	0.90	0.98	1.04
HF	2-1/2	1.91	2.21	2.47	2.76	3.02	3.26	1.42	1.59	1.78	1.94	2.10	2.25	0.87	0.97	1.09	1.19	1.29	1.38
HF	4	3.39	3.91	4.38	4.89	5.36	5.79	2.53	2.83	3.16	3.46	3.74	4.00	1.55	1.73	1.94	2.12	2.29	2.45
HF	6	4.72	5.45	6.09	6.81	7.46	8.06	3.52	3.94	4.40	4.82	5.21	5.57	2.16	2.41	2.70	2.96	3.19	3.42
HF	7-1/2	5.98	6.91	7.72	8.63	9.46	10.21	4.46	4.99	5.58	6.11	6.60	7.05	2.74	3.06	3.43	3.75	4.05	4.33
HF	11	8.87	10.24	11.45	12.80	14.02	15.15	6.62	7.40	8.28	9.06	9.79	10.47	4.06	4.54	5.08	5.56	6.00	6.42
HF	14	11.67	13.48	15.07	16.84	18.45	19.93	8.71	9.74	10.89	11.93	12.88	13.77	5.34	5.97	6.68	7.31	7.90	8.44
TFE	6	4.64	5.36	5.99	6.70	7.34	7.92	3.46	3.87	4.33	4.74	5.12	5.47	2.12	2.37	2.65	2.90	3.14	3.35
TFE	8	6.35	7.33	8.20	9.17	10.04	10.84	4.74	5.30	5.93	6.49	7.01	7.49	2.91	3.25	3.64	3.98	4.30	4.60
TFE	10	7.88	9.10	10.17	11.37	12.46	13.46	5.88	6.57	7.35	8.05	8.70	9.30	3.61	4.04	4.51	4.94	5.34	5.71
TFE	15	12.03	13.89	15.53	17.36	19.02	20.55	8.97	10.03	11.21	12.28	13.27	14.18	5.51	6.16	6.89	7.54	8.15	8.71
TRAE+	9	6.82	7.88	8.80	9.84	10.78	11.65	5.09	5.69	6.36	6.97	7.53	8.05	3.12	3.49	3.90	4.27	4.61	4.93
TRAE+	13	9.94	11.48	12.83	14.35	15.72	16.98	7.42	8.30	9.28	10.16	10.97	11.73	4.55	5.09	5.69	6.23	6.73	7.19
TRAE+	14	11.1	12.82	14.33	16.02	17.55	18.96	8.28	9.26	10.35	11.34	12.25	13.09	5.08	5.68	6.35	6.96	7.51	8.03
TRAE+	22	16.82	19.42	21.71	24.28	26.59	28.73	12.55	14.03	15.69	17.18	18.56	19.84	7.70	8.61	9.63	10.54	11.39	12.17
TRAE+	30	23.12	26.70	29.85	33.37	36.56	39.48	17.25	19.29	21.56	23.62	25.51	27.27	10.59	11.84	13.24	14.50	15.66	16.74
TRAE	40	31.21	36.04	40.29	45.05	49.35	53.30	23.29	26.04	29.11	31.89	34.45	36.82	14.29	15.98	17.86	19.57	21.14	22.59
TRAE	45	34.04	39.31	43.95	49.13	53.82	58.13	25.40	28.40	31.75	34.78	37.57	40.16	15.59	17.43	19.49	21.35	23.06	24.65
TRAE	50	40.52	46.79	52.31	58.49	64.07	69.20	30.23	33.80	37.79	41.39	44.71	47.80	18.55	20.74	23.19	25.40	27.44	29.33
TJR	11	8.50	9.81	10.97	12.27	13.44	14.52	6.34	7.09	7.93	8.68	9.38	10.02	3.89	4.35	4.86	5.33	5.75	6.15
TJR	13	10.17	11.74	13.13	14.68	16.08	17.37	7.59	8.49	9.49	10.39	11.23	12.00	4.66	5.21	5.83	6.38	6.89	7.37
TER	16	12.72	14.69	16.42	18.36	20.11	21.72	9.49	10.61	11.86	12.99	14.04	15.01	5.82	6.51	7.28	7.97	8.61	9.20
TER	19	15.03	17.36	19.40	21.69	23.76	25.67	11.21	12.53	14.01	15.35	16.58	17.72	6.88	7.69	8.60	9.42	10.18	10.88
TER	25	20.23	23.36	26.12	29.20	31.99	34.55	15.09	16.87	18.86	20.66	22.32	23.86	9.26	10.35	11.58	12.68	13.70	14.64
TER	31	26.01	30.03	33.58	37.54	41.13	44.42	19.41	21.70	24.26	26.58	28.71	30.69	11.91	13.32	14.89	16.31	17.62	18.83
TIR	45	31.79	36.71	41.04	45.88	50.26	54.29	23.72	26.52	29.65	32.48	35.08	37.50	14.56	16.28	18.20	19.94	21.53	23.02
THR	55	40.46	46.72	52.23	58.40	63.97	69.10	30.19	33.75	37.74	41.34	44.65	47.73	18.53	20.72	23.16	25.37	27.41	29.30
THR	68	49.13	56.73	63.43	70.91	77.68	83.91	36.66	40.99	45.83	50.20	54.22	57.96	22.50	25.16	28.13	30.81	33.28	35.58
TMR	68	57.80	66.74	74.62	83.43	91.39	98.71	43.12	48.21	53.90	59.04	63.78	68.18	26.47	29.59	33.09	36.25	39.15	41.85

Refrigerant Liquid Temperature Valve Capacity Multiplier Correction Factors

	Refrigerant Liquid Temperature °F															
	0	10	20	30	40	50	60	70	80	90	100	110	120	130	140	
R-12 Correction Factor	1.60	1.54	1.48	1.42	1.36	1.30	1.24	1.18	1.12	1.06	1.00	.94	.88	.82	.75	
R-134a Correction Factor	1.70	1.63	1.56	1.49	1.42	1.36	1.29	1.21	1.14	1.07	1.00	.93	.85	.78	.71	
R-22 Correction Factor	1.56	1.51	1.45	1.40	1.34	1.29	1.23	1.17	1.12	1.06	1.00	.94	.88	.82	.76	
R-404A/R-507 Correction Factor	2.00	1.90	1.80	1.70	1.60	1.50	1.40	1.30	1.20	1.10	1.00	.90	.80	.70	.50	

These factors include corrections for liquid refrigerant density and net refrigerating effect and are based on an average evaporator temperature of 0°F. However, they may be used for any evaporator temperature from -40°F to +40°F since the variation in the actual factors across this range is insignificant.

R-404A/R-507 Balanced Ported Valves (Tons)– HF, TFE, TRAE and T Series

Valve Type	Nominal Rating	Evaporator Temperature																	
		50°F					40°F					20°F							
		Pressure Drop Across Valve (PSI)					Pressure Drop Across Valve (PSI)					Pressure Drop Across Valve (PSI)							
	60	80	100	125	150	175	60	80	100	125	150	175	60	80	100	125	150	175	
HF	1/8	0.16	0.18	0.21	0.23	0.25	0.27	0.16	0.18	0.21	0.23	0.25	0.27	0.15	0.17	0.19	0.22	0.24	0.26
HF	1/4	0.31	0.36	0.40	0.45	0.49	0.53	0.30	0.35	0.39	0.43	0.47	0.51	0.28	0.32	0.36	0.40	0.44	0.48
HF	1/2	0.55	0.64	0.71	0.79	0.87	0.94	0.53	0.61	0.68	0.76	0.84	0.91	0.51	0.59	0.66	0.74	0.81	0.87
HF	1	0.83	0.96	1.07	1.20	1.31	1.42	0.82	0.95	1.06	1.18	1.30	1.40	0.77	0.89	0.99	1.11	1.22	1.32
HF	1-1/4	1.12	1.29	1.45	1.62	1.77	1.91	1.10	1.27	1.42	1.59	1.74	1.88	1.04	1.20	1.34	1.50	1.64	1.78
HF	1-1/2	1.44	1.66	1.86	2.08	2.28	2.46	1.41	1.63	1.82	2.04	2.23	2.41	1.34	1.55	1.73	1.93	2.12	2.29
HF	2	1.90	2.19	2.45	2.74	3.00	3.24	1.86	2.15	2.40	2.68	2.94	3.18	1.76	2.03	2.27	2.54	2.78	3.01
HF	3-1/2	3.38	3.90	4.36	4.88	5.34	5.77	3.30	3.81	4.26	4.76	5.22	5.64	3.13	3.61	4.04	4.52	4.95	5.35
HF	5	4.70	5.43	6.07	6.78	7.43	8.03	4.59	5.30	5.93	6.63	7.26	7.84	4.36	5.03	5.63	6.29	6.89	7.45
HF	7	5.95	6.87	7.68	8.59	9.41	10.16	5.81	6.71	7.50	8.39	9.19	9.92	5.52	6.37	7.13	7.97	8.73	9.43
HF	10	8.83	10.20	11.40	12.75	13.96	15.08	8.62	9.95	11.13	12.44	13.63	14.72	8.19	9.46	10.57	11.82	12.95	13.99
HF	13	11.62	13.42	15.00	16.77	18.37	19.84	11.35	13.11	14.65	16.38	17.95	19.38	10.78	12.45	13.92	15.56	17.04	18.41
TFE	5	4.62	5.33	5.96	6.67	7.30	7.89	4.51	5.21	5.82	6.51	7.13	7.70	4.28	4.94	5.53	6.18	6.77	7.31
TFE	7	6.32	7.30	8.16	9.12	9.99	10.79	6.17	7.12	7.97	8.91	9.76	10.54	5.86	6.77	7.57	8.46	9.27	10.01
TFE	9	7.84	9.05	10.12	11.32	12.40	13.39	7.66	8.85	9.89	11.06	12.11	13.08	7.28	8.41	9.40	10.51	11.51	12.43
TFE	14	11.98	13.83	15.47	17.29	18.94	20.46	11.70	13.51	15.10	16.89	18.50	19.98	11.11	12.83	14.34	16.04	17.57	18.97
TRAE+	8	6.79	7.84	8.77	9.80	10.74	11.60	6.63	7.66	8.56	9.57	10.48	11.32	6.30	7.27	8.13	9.09	9.96	10.76
TRAE+	12	9.90	11.43	12.78	14.29	15.65	16.91	9.67	11.17	12.48	13.96	15.29	16.51	9.19	10.61	11.86	13.26	14.53	15.69
TRAE+	14	11.05	12.76	14.27	15.95	17.47	18.87	10.79	12.46	13.93	15.57	17.06	18.43	10.25	11.84	13.23	14.79	16.21	17.51
TRAE+	20	16.75	19.34	21.62	24.18	26.48	28.61	16.36	18.89	21.12	23.61	25.87	27.94	15.54	17.94	20.06	22.43	24.57	26.54
TRAE+	30	23.02	26.58	29.72	33.23	36.40	39.31	22.49	25.97	29.03	32.46	35.56	38.41	21.36	24.66	27.58	30.83	33.77	36.48
TRAE	35	31.08	35.89	40.12	44.86	49.14	53.08	30.36	35.06	39.19	43.82	48.00	51.85	28.84	33.30	37.23	41.63	45.60	49.25
TRAE	40	33.90	39.14	43.76	48.93	53.60	57.90	33.11	38.23	42.74	47.79	52.35	56.55	31.45	36.32	40.60	45.39	49.73	53.71
TRAE	50	40.34	46.58	52.08	58.23	63.78	68.89	39.41	45.51	50.88	56.88	62.31	67.31	37.44	43.23	48.33	54.04	59.20	63.94
TJR	9	8.46	9.77	10.92	12.21	13.38	14.45	8.26	9.54	10.66	11.92	13.06	14.11	7.85	9.06	10.13	11.33	12.41	13.41
TJR	12	10.13	11.70	13.08	14.62	16.02	17.30	9.89	11.42	12.77	14.27	15.64	16.89	9.40	10.85	12.14	13.57	14.86	16.05
TER	14	12.66	14.62	16.34	18.27	20.02	21.62	12.37	14.28	15.97	17.85	19.56	21.13	11.75	13.57	15.17	16.96	18.58	20.07
TER	16	14.96	17.27	19.31	21.59	23.65	25.55	14.62	16.88	18.87	21.10	23.12	24.97	13.88	16.03	17.92	20.03	21.95	23.70
TER	21	20.14	23.26	26.00	29.07	31.84	34.40	19.68	22.72	25.41	28.41	31.12	33.61	18.69	21.58	24.13	26.98	29.55	31.92
TER	27	25.90	29.91	33.44	37.38	40.95	44.23	25.30	29.21	32.66	36.52	40.00	43.21	24.03	27.75	31.02	34.68	37.99	41.04
TIR	37	31.65	36.55	40.86	45.68	50.04	54.05	30.92	35.70	39.92	44.63	48.89	52.81	29.37	33.91	37.92	42.39	46.44	50.16
THR	48	40.29	46.52	52.01	58.15	63.70	68.81	39.35	45.44	50.80	56.80	62.22	67.20	37.38	43.16	48.26	53.95	59.10	63.84
THR	60	48.92	56.49	63.16	70.61	77.35	83.55	47.78	55.17	61.68	68.96	75.55	81.60	45.39	52.41	58.60	65.51	71.77	77.52
TMR	60	57.55	66.45	74.30	83.07	90.99	98.29	56.22	64.92	72.58	81.15	88.89	96.01	53.40	61.66	68.94	77.08	84.43	91.20

Note: Standard capacity is rated at 100F liquid inlet and 40F evaporator temperature; with 100 Psi pressure drop across the TXV per ARI 750-2001.

Refrigerant Liquid Temperature Valve Capacity Multiplier Correction Factors

	Refrigerant Liquid Temperature °F														
	0	10	20	30	40	50	60	70	80	90	100	110	120	130	140
R-12 Correction Factor	1.60	1.54	1.48	1.42	1.36	1.30	1.24	1.18	1.12	1.06	1.00	.94	.88	.82	.75
R-134a Correction Factor	1.70	1.63	1.56	1.49	1.42	1.36	1.29	1.21	1.14	1.07	1.00	.93	.85	.78	.71
R-22 Correction Factor	1.56	1.51	1.45	1.40	1.34	1.29	1.23	1.17	1.12	1.06	1.00	.94	.88	.82	.76
R-404A/R-507 Correction Factor	2.00	1.90	1.80	1.70	1.60	1.50	1.40	1.30	1.20	1.10	1.00	.90	.80	.70	.50

These factors include corrections for liquid refrigerant density and net refrigerating effect and are based on an average evaporator temperature of 0°F. However, they may be used for any evaporator temperature from -40°F to +40°F since the variation in the actual factors across this range is insignificant.

R-404A/R-507 Balanced Ported Valves (Tons)– HF, TFE, TRAE and T Series (cont.)

Valve Type	Nominal Rating	Evaporator Temperature																	
		0°F						-20°F						-40°F					
		Pressure Drop Across Valve (PSI)						Pressure Drop Across Valve (PSI)						Pressure Drop Across Valve (PSI)					
		60	80	100	125	150	175	80	100	125	150	175	200	80	100	125	150	175	200
HF	1/8	0.13	0.15	0.17	0.19	0.21	0.22	0.10	0.11	0.13	0.14	0.15	0.16	0.07	0.08	0.09	0.10	0.10	0.11
HF	1/4	0.25	0.29	0.32	0.36	0.40	0.43	0.20	0.22	0.25	0.27	0.30	0.32	0.13	0.15	0.16	0.18	0.19	0.21
HF	1/2	0.45	0.52	0.58	0.65	0.71	0.77	0.36	0.40	0.45	0.49	0.53	0.57	0.23	0.26	0.29	0.31	0.34	0.36
HF	1	0.69	0.80	0.89	1.00	1.09	1.18	0.54	0.60	0.68	0.74	0.80	0.85	0.35	0.39	0.44	0.48	0.52	0.55
HF	1-1/4	0.93	1.07	1.20	1.34	1.47	1.59	0.73	0.82	0.91	1.00	1.08	1.15	0.48	0.54	0.60	0.66	0.71	0.76
HF	1-1/2	1.19	1.37	1.54	1.72	1.88	2.03	0.93	1.04	1.16	1.27	1.38	1.47	0.61	0.68	0.76	0.84	0.90	0.96
HF	2	1.57	1.81	2.03	2.27	2.48	2.68	1.23	1.38	1.54	1.68	1.82	1.94	0.81	0.91	1.01	1.11	1.20	1.28
HF	3-1/2	2.80	3.23	3.61	4.04	4.43	4.78	2.19	2.45	2.74	3.00	3.24	3.46	1.43	1.60	1.79	1.96	2.11	2.26
HF	5	3.89	4.49	5.02	5.61	6.15	6.64	3.05	3.41	3.81	4.18	4.51	4.82	2.00	2.24	2.50	2.74	2.96	3.16
HF	7	4.93	5.69	6.36	7.12	7.80	8.42	3.87	4.33	4.84	5.30	5.72	6.12	2.53	2.83	3.16	3.46	3.74	4.00
HF	10	7.31	8.44	9.44	10.55	11.56	12.48	5.73	6.41	7.16	7.85	8.47	9.06	3.75	4.19	4.69	5.13	5.55	5.93
HF	13	9.62	11.11	12.42	13.89	15.21	16.43	7.55	8.44	9.44	10.34	11.17	11.94	4.93	5.51	6.16	6.75	7.29	7.80
TFE	5	3.82	4.41	4.93	5.51	6.04	6.52	3.00	3.35	3.75	4.11	4.44	4.74	1.96	2.19	2.45	2.68	2.90	3.10
TFE	7	5.23	6.04	6.75	7.55	8.27	8.93	4.10	4.58	5.13	5.61	6.06	6.48	2.68	3.00	3.35	3.67	3.96	4.24
TFE	9	6.50	7.51	8.39	9.38	10.28	11.10	5.10	5.70	6.38	6.98	7.54	8.06	3.33	3.72	4.16	4.56	4.93	5.27
TFE	14	9.92	11.45	12.81	14.32	15.68	16.94	7.78	8.70	9.73	10.65	11.51	12.30	5.08	5.68	6.35	6.96	7.51	8.03
TRAE+	8	5.62	6.49	7.26	8.11	8.89	9.60	4.41	4.93	5.51	6.04	6.52	6.97	2.88	3.22	3.60	3.94	4.26	4.55
TRAE+	12	8.20	9.47	10.59	11.84	12.97	14.00	6.43	7.19	8.04	8.80	9.51	10.17	4.20	4.70	5.25	5.75	6.21	6.64
TRAE+	14	9.15	10.57	11.81	13.21	14.47	15.63	7.18	8.03	8.98	9.83	10.62	11.35	4.69	5.24	5.86	6.42	6.94	7.42
TRAE+	20	13.87	16.02	17.91	20.02	21.93	23.69	10.88	12.16	13.60	14.90	16.09	17.20	7.11	7.95	8.89	9.74	10.52	11.24
TRAE+	30	19.06	22.01	24.61	27.51	30.14	32.55	14.95	16.71	18.69	20.47	22.11	23.64	9.77	10.92	12.21	13.38	14.45	15.45
TRAE	35	25.73	29.71	33.22	37.14	40.68	43.94	20.19	22.57	25.24	27.65	29.86	31.92	13.19	14.75	16.49	18.06	19.51	20.86
TRAE	40	28.07	32.41	36.24	40.52	44.38	47.94	22.02	24.62	27.53	30.15	32.57	34.82	14.39	16.09	17.99	19.70	21.28	22.75
TRAE	50	33.41	38.58	43.13	48.22	52.83	57.06	26.20	29.29	32.75	35.88	38.75	41.43	17.13	19.15	21.41	23.46	25.34	27.08
TJR	9	7.01	8.09	9.05	10.12	11.08	11.97	5.50	6.15	6.88	7.53	8.13	8.70	3.59	4.01	4.49	4.92	5.31	5.68
TJR	12	8.39	9.69	10.83	12.11	13.27	14.33	6.58	7.36	8.23	9.01	9.73	10.40	4.30	4.81	5.38	5.89	6.36	6.80
TER	14	10.48	12.10	13.53	15.13	16.57	17.90	8.22	9.19	10.28	11.26	12.16	13.00	5.30	5.93	6.63	7.26	7.84	8.38
TER	16	12.39	14.31	16.00	17.88	19.59	21.16	9.72	10.87	12.15	13.31	14.38	15.37	6.35	7.10	7.94	8.70	9.39	10.04
TER	21	16.68	19.26	21.53	24.08	26.37	28.49	13.08	14.62	16.35	17.91	19.35	20.68	8.55	9.56	10.69	11.71	12.65	13.52
TER	27	21.45	24.77	27.69	30.96	33.92	36.63	16.82	18.81	21.03	23.03	24.88	26.59	11.00	12.30	13.75	15.06	16.27	17.39
TIR	37	26.21	30.26	33.84	37.83	41.44	44.76	20.56	22.99	25.70	28.15	30.41	32.51	13.44	15.03	16.80	18.40	19.88	21.25
THR	48	33.36	38.52	43.07	48.15	52.75	56.97	26.17	29.26	32.71	35.83	38.71	41.38	17.10	19.12	21.38	23.42	25.29	27.04
THR	60	40.51	46.78	52.30	58.47	64.05	69.18	31.77	35.52	39.71	43.50	46.99	50.23	20.77	23.22	25.96	28.44	30.72	32.84
TMR	60	47.66	55.03	61.53	68.79	75.36	81.39	37.38	41.79	46.73	51.18	55.29	59.10	24.43	27.31	30.54	33.45	36.13	38.63

Refrigerant Liquid Temperature Valve Capacity Multiplier Correction Factors

	Refrigerant Liquid Temperature °F														
	0	10	20	30	40	50	60	70	80	90	100	110	120	130	140
R-12 Correction Factor	1.60	1.54	1.48	1.42	1.36	1.30	1.24	1.18	1.12	1.06	1.00	.94	.88	.82	.75
R-134a Correction Factor	1.70	1.63	1.56	1.49	1.42	1.36	1.29	1.21	1.14	1.07	1.00	.93	.85	.78	.71
R-22 Correction Factor	1.56	1.51	1.45	1.40	1.34	1.29	1.23	1.17	1.12	1.06	1.00	.94	.88	.82	.76
R-404A/R-507 Correction Factor	2.00	1.90	1.80	1.70	1.60	1.50	1.40	1.30	1.20	1.10	1.00	.90	.80	.70	.50

These factors include corrections for liquid refrigerant density and net refrigerating effect and are based on an average evaporator temperature of 0°F. However, they may be used for any evaporator temperature from -40°F to +40°F since the variation in the actual factors across this range is insignificant.

R-407C Balanced Ported Valves (Tons)– HF, TFE, TRAE and T Series

Valve Type	Nominal Rating	Evaporator Temperature																	
		50°F						40°F						20°F					
		Pressure Drop Across Valve (PSI)						Pressure Drop Across Valve (PSI)						Pressure Drop Across Valve (PSI)					
		60	80	100	125	150	175	60	80	100	125	150	175	60	80	100	125	150	175
HF	1/4	0.21	0.24	0.27	0.30	0.33	0.36	0.21	0.24	0.27	0.30	0.33	0.36	0.20	0.23	0.26	0.29	0.32	0.34
HF	1/2	0.40	0.46	0.52	0.58	0.63	0.68	0.39	0.45	0.50	0.56	0.62	0.67	0.38	0.44	0.49	0.55	0.60	0.65
HF	1	0.72	0.83	0.93	1.04	1.14	1.23	0.70	0.81	0.90	1.01	1.11	1.20	0.68	0.79	0.88	0.98	1.08	1.16
HF	1-1/2	1.09	1.26	1.41	1.57	1.72	1.86	1.07	1.24	1.38	1.54	1.69	1.83	1.03	1.19	1.33	1.49	1.63	1.76
HF	2	1.47	1.70	1.90	2.12	2.32	2.51	1.44	1.66	1.86	2.08	2.28	2.46	1.39	1.61	1.79	2.01	2.20	2.37
HF	2-1/2	1.88	2.17	2.43	2.71	2.97	3.21	1.85	2.14	2.39	2.67	2.93	3.16	1.78	2.06	2.30	2.57	2.81	3.04
HF	3	2.49	2.88	3.21	3.59	3.94	4.25	2.44	2.82	3.15	3.52	3.86	4.17	2.35	2.71	3.03	3.39	3.72	4.01
HF	5-1/2	4.43	5.12	5.72	6.39	7.00	7.57	4.34	5.01	5.60	6.26	6.86	7.41	4.17	4.82	5.38	6.02	6.59	7.12
HF	8	6.16	7.11	7.95	8.89	9.74	10.52	6.05	6.99	7.81	8.73	9.57	10.33	5.81	6.71	7.50	8.39	9.19	9.92
HF	10	7.80	9.01	10.07	11.26	12.33	13.32	7.65	8.83	9.88	11.04	12.10	13.06	7.35	8.49	9.49	10.61	11.62	12.55
HF	15	11.57	13.36	14.94	16.70	18.29	19.76	11.35	13.11	14.65	16.38	17.95	19.38	10.90	12.59	14.07	15.73	17.23	18.62
HF	20	15.22	17.57	19.65	21.97	24.06	25.99	14.94	17.25	19.29	21.56	23.62	25.51	14.35	16.57	18.53	20.71	22.69	24.51
TFE	8	6.05	6.99	7.81	8.73	9.57	10.33	5.94	6.86	7.67	8.57	9.39	10.14	5.70	6.58	7.36	8.23	9.01	9.73
TFE	10	8.28	9.56	10.69	11.95	13.09	14.14	8.13	9.39	10.50	11.73	12.85	13.88	7.80	9.01	10.07	11.26	12.33	13.32
TFE	12	10.28	11.87	13.27	14.84	16.25	17.56	10.09	11.65	13.03	14.56	15.95	17.23	9.69	11.19	12.51	13.99	15.32	16.55
TFE	20	15.69	18.12	20.26	22.65	24.81	26.80	15.40	17.78	19.88	22.23	24.35	26.30	14.79	17.08	19.09	21.35	23.39	25.26
TRAE+	10	8.90	10.28	11.49	12.85	14.07	15.20	8.73	10.08	11.27	12.60	13.80	14.91	8.39	9.69	10.83	12.11	13.27	14.33
TRAE+	15	12.97	14.98	16.74	18.72	20.51	22.15	12.73	14.70	16.43	18.37	20.13	21.74	12.22	14.11	15.78	17.64	19.32	20.87
TRAE+	20	14.48	16.72	18.69	20.90	22.89	24.73	14.21	16.41	18.35	20.51	22.47	24.27	13.64	15.75	17.61	19.69	21.57	23.29
TRAE+	30	21.94	25.33	28.32	31.67	34.69	37.47	21.45	24.77	27.69	30.96	33.92	36.63	20.68	23.88	26.70	29.85	32.70	35.32
TRAE+	40	30.16	34.83	38.94	43.53	47.69	51.51	29.60	34.18	38.21	42.72	46.80	50.55	28.43	32.83	36.70	41.04	44.95	48.55
TRAE	50	40.71	47.01	52.56	58.76	64.37	69.53	39.97	46.15	51.60	57.69	63.20	68.26	38.37	44.31	49.54	55.38	60.67	65.53
TRAE	60	44.41	51.28	57.33	64.10	70.22	75.84	43.59	50.33	56.27	62.92	68.92	74.44	41.86	48.34	54.04	60.42	66.19	71.49
TRAE	70	52.85	61.03	68.23	76.28	83.56	90.26	51.88	59.91	66.98	74.88	82.03	88.60	49.82	57.53	64.32	71.91	78.77	85.08
TJR	14	11.08	12.79	14.30	15.99	17.52	18.92	10.88	12.56	14.05	15.70	17.20	18.58	10.45	12.07	13.49	15.08	16.52	17.85
TJR	18	13.27	15.32	17.13	19.15	20.98	22.66	13.03	15.05	16.82	18.81	20.60	22.25	12.51	14.45	16.15	18.06	19.78	21.36
TER	22	16.59	19.16	21.42	23.95	26.23	28.33	16.28	18.80	21.02	23.50	25.74	27.80	15.63	18.05	20.18	22.56	24.71	26.69
TER	26	19.60	22.63	25.30	28.29	30.99	33.47	19.24	22.22	24.84	27.77	30.42	32.86	18.48	21.34	23.86	26.67	29.22	31.56
TER	35	26.39	30.47	34.07	38.09	41.73	45.07	25.90	29.91	33.44	37.38	40.95	44.23	24.87	28.72	32.11	35.90	39.32	42.47
TER	45	33.93	39.18	43.80	48.97	53.65	57.95	33.30	38.45	42.99	48.06	52.65	56.87	31.98	36.93	41.29	46.16	50.56	54.62
TIR	55	41.47	47.89	53.54	59.86	65.57	70.82	40.71	47.01	52.56	58.76	64.37	69.53	39.08	45.13	50.45	56.41	61.79	66.74
THR	75	52.78	60.95	68.14	76.18	83.45	90.14	51.81	59.83	66.89	74.78	81.92	88.48	49.74	57.43	64.21	71.79	78.65	84.95
THR	100	64.08	73.99	82.73	92.49	101.32	109.44	62.91	72.64	81.22	90.80	99.47	107.44	60.40	69.74	77.98	87.18	95.50	103.15
TMR	100	75.39	87.05	97.33	108.82	119.20	128.75	74.01	85.46	95.55	106.82	117.02	126.40	71.06	82.05	91.74	102.57	112.36	121.36

Note: Standard capacity is rated at 100F liquid inlet and 40F evaporator temperature; with 100 Psi pressure drop across the TXV per ARI 750-2001.

Refrigerant Liquid Temperature Valve Capacity Multiplier Correction Factors

	Refrigerant Liquid Temperature °F															
	0	10	20	30	40	50	60	70	80	90	100	110	120	130	140	
R-12 Correction Factor	1.60	1.54	1.48	1.42	1.36	1.30	1.24	1.18	1.12	1.06	1.00	.94	.88	.82	.75	
R-134a Correction Factor	1.70	1.63	1.56	1.49	1.42	1.36	1.29	1.21	1.14	1.07	1.00	.93	.85	.78	.71	
R-22 Correction Factor	1.56	1.51	1.45	1.40	1.34	1.29	1.23	1.17	1.12	1.06	1.00	.94	.88	.82	.76	
R-404A/R-507 Correction Factor	2.00	1.90	1.80	1.70	1.60	1.50	1.40	1.30	1.20	1.10	1.00	.90	.80	.70	.50	

These factors include corrections for liquid refrigerant density and net refrigerating effect and are based on an average evaporator temperature of 0°F. However, they may be used for any evaporator temperature from -40°F to +40°F since the variation in the actual factors across this range is insignificant.

R-407C Balanced Ported Valves (Tons)– HF, TFE, TRAE and T Series (cont.)

Valve Type	Nominal Rating	Evaporator Temperature																	
		0°F						-20°F						-40°F					
		Pressure Drop Across Valve (PSI)						Pressure Drop Across Valve (PSI)						Pressure Drop Across Valve (PSI)					
		60	80	100	125	150	175	80	100	125	150	175	200	80	100	125	150	175	200
HF	1/4	0.17	0.20	0.22	0.25	0.27	0.29	0.13	0.15	0.16	0.18	0.19	0.21	0.08	0.09	0.10	0.11	0.12	0.13
HF	1/2	0.32	0.37	0.41	0.46	0.51	0.55	0.24	0.27	0.30	0.33	0.35	0.38	0.15	0.17	0.19	0.21	0.22	0.24
HF	1	0.57	0.66	0.74	0.82	0.90	0.97	0.43	0.48	0.54	0.59	0.64	0.68	0.27	0.30	0.34	0.37	0.40	0.43
HF	1-1/2	0.87	1.00	1.12	1.26	1.38	1.49	0.66	0.74	0.83	0.90	0.98	1.04	0.42	0.47	0.53	0.58	0.62	0.66
HF	2	1.17	1.35	1.51	1.69	1.85	2.00	0.89	1.00	1.11	1.22	1.32	1.41	0.56	0.63	0.70	0.77	0.83	0.89
HF	2-1/2	1.50	1.73	1.94	2.17	2.37	2.56	1.14	1.27	1.43	1.56	1.69	1.80	0.72	0.80	0.90	0.99	1.06	1.14
HF	3	1.98	2.29	2.56	2.86	3.13	3.38	1.51	1.69	1.89	2.07	2.23	2.39	0.95	1.06	1.19	1.30	1.41	1.50
HF	3-1/2	3.52	4.06	4.54	5.08	5.57	6.01	2.68	3.00	3.35	3.67	3.96	4.24	1.69	1.89	2.11	2.31	2.50	2.67
HF	4	4.90	5.66	6.33	7.07	7.75	8.37	3.73	4.17	4.66	5.11	5.52	5.90	2.35	2.63	2.94	3.22	3.48	3.72
HF	5	6.20	7.16	8.00	8.95	9.80	10.59	4.72	5.28	5.90	6.46	6.98	7.46	2.97	3.32	3.71	4.07	4.39	4.70
HF	6	9.20	10.62	11.88	13.28	14.55	15.71	7.01	7.84	8.76	9.60	10.37	11.08	4.41	4.93	5.51	6.04	6.52	6.97
HF	8	12.11	13.98	15.63	17.48	19.15	20.68	9.22	10.31	11.53	12.63	13.64	14.58	5.81	6.50	7.26	7.96	8.59	9.19
TFE	8	4.81	5.55	6.21	6.94	7.61	8.21	3.66	4.09	4.58	5.01	5.41	5.79	2.31	2.58	2.89	3.16	3.42	3.65
TFE	10	6.59	7.61	8.51	9.51	10.42	11.25	5.02	5.61	6.28	6.87	7.42	7.94	3.16	3.53	3.95	4.33	4.67	5.00
TFE	12	8.18	9.45	10.56	11.81	12.93	13.97	6.23	6.97	7.79	8.53	9.21	9.85	3.92	4.38	4.90	5.37	5.80	6.20
TFE	20	12.49	14.42	16.12	18.03	19.75	21.33	9.51	10.63	11.89	13.02	14.07	15.04	5.98	6.69	7.48	8.19	8.84	9.46
TRAE+	10	7.08	8.18	9.14	10.22	11.19	12.09	5.39	6.03	6.74	7.38	7.97	8.52	3.39	3.79	4.24	4.64	5.01	5.36
TRAE+	15	10.32	11.92	13.32	14.90	16.32	17.62	7.86	8.79	9.83	10.76	11.63	12.43	4.95	5.53	6.19	6.78	7.32	7.83
TRAE+	20	11.52	13.30	14.87	16.63	18.21	19.67	8.77	9.81	10.96	12.01	12.97	13.87	5.52	6.17	6.90	7.56	8.16	8.73
TRAE+	30	17.46	20.16	22.54	25.20	27.61	29.82	13.30	14.87	16.63	18.21	19.67	21.03	8.37	9.36	10.46	11.46	12.38	13.23
TRAE+	40	24.00	27.71	30.98	34.64	37.95	40.99	18.28	20.44	22.85	25.03	27.04	28.90	11.50	12.86	14.38	15.75	17.01	18.18
TRAE+	50	32.40	37.41	41.83	46.77	51.23	55.33	24.67	27.58	30.84	33.78	36.49	39.01	15.53	17.36	19.41	21.27	22.97	24.56
TRAE	60	35.34	40.81	45.62	51.01	55.88	60.35	26.91	30.09	33.64	36.85	39.80	42.55	16.94	18.94	21.18	23.20	25.05	26.78
TRAE	70	42.06	48.57	54.30	60.71	66.50	71.83	32.03	35.81	40.04	43.86	47.37	50.64	20.16	22.54	25.20	27.61	29.82	31.88
TJR	14	8.82	10.18	11.39	12.73	13.95	15.06	6.72	7.51	8.40	9.20	9.94	10.63	4.23	4.73	5.29	5.79	6.26	6.69
TJR	18	10.56	12.19	13.63	15.24	16.70	18.03	8.04	8.99	10.05	11.01	11.89	12.71	5.06	5.66	6.33	6.93	7.48	8.00
TER	22	13.20	15.24	17.04	19.05	20.87	22.54	10.05	11.24	12.56	13.76	14.86	15.89	6.33	7.08	7.91	8.67	9.36	10.01
TER	26	15.60	18.01	20.14	22.52	24.67	26.64	11.88	13.28	14.85	16.27	17.57	18.78	7.48	8.36	9.35	10.24	11.06	11.83
TER	35	21.00	24.25	27.11	30.31	33.20	35.86	15.99	17.88	19.99	21.90	23.65	25.28	10.06	11.25	12.58	13.78	14.88	15.91
TER	45	27.00	31.18	34.86	38.97	42.69	46.11	20.56	22.99	25.70	28.15	30.41	32.51	12.94	14.47	16.18	17.72	19.14	20.46
TIR	55	33.00	38.11	42.60	47.63	52.18	56.36	25.13	28.10	31.41	34.41	37.17	39.73	15.82	17.69	19.78	21.66	23.40	25.01
THR	75	42.00	48.50	54.22	60.62	66.41	71.73	31.98	35.75	39.98	43.79	47.30	50.56	20.13	22.51	25.16	27.56	29.77	31.83
THR	100	51.00	58.89	65.84	73.61	80.64	87.10	38.84	43.42	48.55	53.18	57.45	61.41	24.44	27.32	30.55	33.47	36.15	38.64
TMR	100	60.00	69.28	77.46	86.60	94.87	102.47	45.69	51.08	57.11	62.56	67.58	72.24	28.76	32.15	35.95	39.38	42.54	45.47

Refrigerant Liquid Temperature Valve Capacity Multiplier Correction Factors

	Refrigerant Liquid Temperature °F															
	0	10	20	30	40	50	60	70	80	90	100	110	120	130	140	
R-12 Correction Factor	1.60	1.54	1.48	1.42	1.36	1.30	1.24	1.18	1.12	1.06	1.00	.94	.88	.82	.75	
R-134a Correction Factor	1.70	1.63	1.56	1.49	1.42	1.36	1.29	1.21	1.14	1.07	1.00	.93	.85	.78	.71	
R-22 Correction Factor	1.56	1.51	1.45	1.40	1.34	1.29	1.23	1.17	1.12	1.06	1.00	.94	.88	.82	.76	
R-404A/R-507 Correction Factor	2.00	1.90	1.80	1.70	1.60	1.50	1.40	1.30	1.20	1.10	1.00	.90	.80	.70	.50	

These factors include corrections for liquid refrigerant density and net refrigerating effect and are based on an average evaporator temperature of 0°F. However, they may be used for any evaporator temperature from -40°F to +40°F since the variation in the actual factors across this range is insignificant.

R-410A Balanced Ported Valves (Tons) – NXT Series

Valve Type	Nominal Rating Tons	Evaporator Temperature																				
		50 °F							40 °F							20 °F						
		Pressure Drop Across Valve (PSI)							Pressure Drop Across Valve (PSI)							Pressure Drop Across Valve (PSI)						
		75	110	140	160	210	240	285	75	110	140	160	210	240	285	75	110	140	160	210	240	285
NXT-Series	1/2	0.4	0.5	0.5	0.6	0.6	0.7	0.8	0.4	0.5	0.5	0.6	0.6	0.7	0.7	0.4	0.5	0.5	0.5	0.6	0.7	0.7
	1	0.7	0.8	0.9	1.0	1.2	1.2	1.3	0.7	0.8	0.9	1.0	1.1	1.2	1.3	0.7	0.8	0.9	1.0	1.1	1.2	1.3
	1-1/2	1.0	1.3	1.4	1.5	1.7	1.9	2.0	1.0	1.2	1.4	1.5	1.7	1.8	2.0	1.0	1.2	1.4	1.5	1.7	1.8	2.0
	2	1.4	1.7	1.9	2.0	2.3	2.5	2.7	1.4	1.7	1.9	2.0	2.3	2.4	2.7	1.3	1.6	1.8	2.0	2.2	2.4	2.6
	3	2.1	2.5	2.8	3.0	3.5	3.7	4.0	2.1	2.5	2.8	3.0	3.4	3.7	4.0	2.0	2.4	2.7	2.9	3.4	3.6	3.9
	4	2.8	3.3	3.8	4.0	4.6	4.9	5.4	2.7	3.3	3.7	4.0	4.4	4.9	5.3	2.7	3.2	3.7	3.9	4.5	4.8	5.2
	5	3.5	4.2	4.7	5.0	5.8	6.2	6.7	3.4	4.1	4.7	5.0	5.7	6.1	6.7	3.3	4.1	4.6	4.9	5.6	6.0	6.5
	6	4.1	5.0	5.7	6.1	6.9	7.4	8.1	4.1	5.0	5.6	6.0	6.9	7.3	8.0	4.0	4.9	5.5	5.9	6.7	7.2	7.8
	7	4.8	5.9	6.6	7.1	8.1	8.6	9.4	4.8	5.8	6.5	7.0	8.0	8.6	9.3	4.7	5.7	6.4	6.8	7.8	8.4	9.1
	8	5.8	7.0	7.9	8.5	9.7	10.4	11.3	5.7	7.0	7.8	8.4	9.6	10.3	11.2	5.6	6.8	7.7	8.2	9.4	10.1	11.0
	10	7.1	8.6	9.7	10.4	11.9	12.7	13.9	7.1	8.5	9.6	10.3	11.8	12.6	13.8	6.9	8.4	9.4	10.1	11.6	12.4	13.5
	12	8.7	10.6	11.9	12.7	14.6	15.6	17.0	8.6	10.5	11.8	12.6	14.5	15.5	16.9	8.5	10.2	11.6	12.4	14.2	15.1	16.5
	15	10.2	12.4	14.0	14.9	17.1	18.3	19.9	10.1	12.3	13.8	14.8	16.9	18.1	19.7	9.9	12.0	13.5	14.5	16.6	17.7	19.3
	Valve Type	Nominal Rating Tons	Evaporator Temperature																			
			0 °F							-20 °F							-40 °F					
Pressure Drop Across Valve (PSI)							Pressure Drop Across Valve (PSI)							Pressure Drop Across Valve (PSI)								
		75	110	140	160	210	240	285	75	110	140	160	210	240	285	75	110	140	160	210	240	285
NXT-Series	1/2	0.4	0.4	0.5	0.5	0.6	0.7	0.7	0.4	0.4	0.5	0.5	0.6	0.6	0.7	0.3	0.4	0.5	0.6	0.6	0.6	0.7
	1	0.7	0.8	0.9	1.0	1.1	1.2	1.3	0.6	0.6	0.9	0.9	1.1	1.1	1.2	0.6	0.7	0.8	0.9	1.0	1.1	1.2
	1-1/2	1.0	1.2	1.3	1.4	1.6	1.8	1.9	0.9	1.1	1.3	1.4	1.6	1.7	1.8	0.9	1.1	1.2	1.3	1.5	1.6	1.8
	2	1.3	1.6	1.8	1.9	2.2	2.3	2.5	1.3	1.5	1.7	1.8	2.1	2.3	2.5	1.2	1.5	1.7	1.8	2.0	2.2	2.4
	3	2.0	2.4	2.7	2.9	3.3	3.5	3.8	1.9	2.3	2.6	2.8	3.2	3.4	3.7	1.8	2.2	2.5	2.7	3.1	3.3	3.6
	4	2.6	3.2	3.6	3.8	4.4	4.7	5.1	2.5	3.1	3.5	3.7	4.2	4.5	4.9	2.4	3.0	3.3	3.6	4.1	4.4	4.8
	5	3.3	3.9	4.5	4.8	5.5	5.8	6.4	3.2	3.8	4.3	4.6	5.3	5.7	6.2	3.0	3.7	4.2	4.5	5.1	5.5	5.9
	6	3.9	4.7	5.3	5.7	6.5	7.0	7.6	3.8	4.6	5.2	5.5	6.3	6.8	7.4	3.7	4.4	5.0	5.3	6.1	6.5	7.1
	7	4.8	5.9	6.6	6.7	8.1	8.6	9.4	4.4	5.4	6.0	6.5	7.4	7.9	8.6	4.3	5.2	5.8	6.2	7.1	7.6	8.3
	8	5.5	6.6	7.5	8.0	9.2	9.8	10.7	5.3	6.4	7.2	7.7	8.9	9.5	10.3	5.1	6.2	7.0	7.5	8.6	9.2	10.0
	10	6.7	8.1	9.2	9.8	11.3	12.0	13.1	6.5	7.9	8.9	9.5	10.9	11.7	12.7	6.3	7.6	8.6	9.2	10.5	11.2	12.3
	12	8.2	10.0	11.3	12.0	13.8	14.7	16.1	8.0	9.7	10.9	11.7	13.4	14.3	15.6	7.7	9.3	10.5	11.2	12.9	13.8	15.0
	15	9.6	11.7	13.2	14.1	16.1	17.3	18.8	9.3	11.3	12.8	13.7	15.6	16.7	18.2	9.0	10.3	12.3	13.2	15.1	15.1	17.6

Note: Standard capacity is rated at 100 °F liquid inlet and 40 °F evap temperature; with 160 Psi pressure drop across TXV per ARI-750-2001. These ratings assume vapor free liquid entering the thermal expansion valve.

Refrigerant Liquid Temperature Valve Capacity Multiplier Correction Factors

	Refrigerant Liquid Temperature °F									
	50	60	70	80	90	100	110	120	130	140
R-410A Correction Factor	1.37	1.30	1.23	1.15	1.08	1.00	0.92	0.84	0.75	0.65

These factors include corrections for liquid refrigerant density and net refrigeration effect, and are based on an average evaporator temperature of 0°F with a maximum 7°F Change in Superheat. However, they may be used for any evaporator temperature from -40°F to +40°F since the variation in the actual factors across this range is insignificant.

R-502 Balanced Ported Valves (Tons)– HF, TFE, TRAE and T Series

Valve Type	Nominal Rating	Evaporator Temperature																	
		50°F						40°F						20°F					
		Pressure Drop Across Valve (PSI)						Pressure Drop Across Valve (PSI)						Pressure Drop Across Valve (PSI)					
	60	80	100	125	150	175	60	80	100	125	150	175	60	80	100	125	150	175	
HF	1/8	0.14	0.16	0.18	0.20	0.22	0.24	0.14	0.16	0.18	0.20	0.22	0.24	0.13	0.15	0.17	0.19	0.21	0.22
HF	1/4	0.27	0.31	0.35	0.39	0.43	0.46	0.27	0.31	0.35	0.39	0.43	0.46	0.25	0.29	0.32	0.36	0.40	0.43
HF	1/2	0.49	0.57	0.63	0.71	0.77	0.84	0.48	0.55	0.62	0.69	0.76	0.82	0.46	0.53	0.59	0.66	0.73	0.79
HF	1	0.74	0.85	0.96	1.07	1.17	1.26	0.73	0.84	0.94	1.05	1.15	1.25	0.70	0.81	0.90	1.01	1.11	1.20
HF	1-1/4	1.00	1.15	1.29	1.44	1.58	1.71	0.98	1.13	1.27	1.41	1.55	1.67	0.93	1.07	1.20	1.34	1.47	1.59
HF	1-1/2	1.28	1.48	1.65	1.85	2.02	2.19	1.26	1.45	1.63	1.82	1.99	2.15	1.20	1.39	1.55	1.73	1.90	2.05
HF	2	1.69	1.95	2.18	2.44	2.67	2.89	1.66	1.92	2.14	2.40	2.62	2.83	1.58	1.82	2.04	2.28	2.50	2.70
HF	3-1/2	3.01	3.48	3.89	4.34	4.76	5.14	2.95	3.41	3.81	4.26	4.66	5.04	2.81	3.24	3.63	4.06	4.44	4.80
HF	5	4.19	4.84	5.41	6.05	6.62	7.16	4.10	4.73	5.29	5.92	6.48	7.00	3.92	4.53	5.06	5.66	6.20	6.69
HF	7	5.30	6.12	6.84	7.65	8.38	9.05	5.19	5.99	6.70	7.49	8.21	8.86	4.96	5.73	6.40	7.16	7.84	8.47
HF	10	7.87	9.09	10.16	11.36	12.44	13.44	7.70	8.89	9.94	11.11	12.17	13.15	7.35	8.49	9.49	10.61	11.62	12.55
HF	13	10.36	11.96	13.37	14.95	16.38	17.69	10.14	11.71	13.09	14.64	16.03	17.32	9.68	11.18	12.50	13.97	15.31	16.53
TFE	5	4.11	4.75	5.31	5.93	6.50	7.02	4.03	4.65	5.20	5.82	6.37	6.88	3.84	4.43	4.96	5.54	6.07	6.56
TFE	7	5.63	6.50	7.27	8.13	8.90	9.62	5.51	6.36	7.11	7.95	8.71	9.41	5.26	6.07	6.79	7.59	8.32	8.98
TFE	9	6.99	8.07	9.02	10.09	11.05	11.94	6.85	7.91	8.84	9.89	10.83	11.70	6.53	7.54	8.43	9.43	10.32	11.15
TFE	14	10.68	12.33	13.79	15.42	16.89	18.24	10.45	12.07	13.49	15.08	16.52	17.85	9.97	11.51	12.87	14.39	15.76	17.03
TRAE+	8	6.05	6.99	7.81	8.73	9.57	10.33	5.93	6.85	7.66	8.56	9.38	10.13	5.66	6.54	7.31	8.17	8.95	9.67
TRAE+	12	8.82	10.18	11.39	12.73	13.95	15.06	8.64	9.98	11.15	12.47	13.66	14.76	8.24	9.51	10.64	11.89	13.03	14.07
TRAE+	14	9.85	11.37	12.72	14.22	15.57	16.82	9.64	11.13	12.45	13.91	15.24	16.46	9.20	10.62	11.88	13.28	14.55	15.71
TRAE+	20	14.93	17.24	19.27	21.55	23.61	25.50	14.61	16.87	18.86	21.09	23.10	24.95	13.95	16.11	18.01	20.14	22.06	23.82
TRAE+	30	20.52	23.69	26.49	29.62	32.44	35.04	20.09	23.20	25.94	29.00	31.77	34.31	19.17	22.14	24.75	27.67	30.31	32.74
TRAE	35	27.70	31.99	35.76	39.98	43.80	47.31	27.12	31.32	35.01	39.14	42.88	46.32	25.88	29.88	33.41	37.35	40.92	44.20
TRAE	40	30.22	34.90	39.01	43.62	47.78	51.61	29.58	34.16	38.19	42.70	46.77	50.52	28.23	32.60	36.44	40.75	44.64	48.21
TRAE	50	35.96	41.52	46.42	51.90	56.86	61.41	35.21	40.66	45.46	50.82	55.67	60.13	35.21	40.66	45.46	50.82	55.67	60.13
TJR	9	7.54	8.71	9.73	10.88	11.92	12.88	7.38	8.52	9.53	10.65	11.67	12.60	7.05	8.14	9.10	10.18	11.15	12.04
TJR	12	9.03	10.43	11.66	13.03	14.28	15.42	8.84	10.21	11.41	12.76	13.98	15.10	8.44	9.75	10.90	12.19	13.35	14.42
TER	14	11.29	13.04	14.58	16.30	17.85	19.28	11.05	12.76	14.27	15.95	17.47	18.87	10.56	12.19	13.63	15.24	16.70	18.03
TER	16	13.34	15.40	17.22	19.25	21.09	22.78	13.06	15.08	16.86	18.85	20.65	22.30	12.48	14.41	16.11	18.01	19.73	21.31
TER	21	17.96	20.74	23.19	25.92	28.40	30.67	17.58	20.30	22.70	25.37	27.80	30.02	16.80	19.39	21.68	24.24	26.56	28.69
TER	27	23.09	26.66	29.81	33.33	36.51	39.43	22.60	26.10	29.18	32.62	35.73	38.60	21.59	24.93	27.87	31.16	34.14	36.87
TIR	37	28.22	32.59	36.43	40.73	44.62	48.19	27.62	31.89	35.66	39.87	43.67	47.17	26.39	30.47	34.06	38.08	41.72	45.06
THR	48	35.91	41.47	46.36	51.83	56.78	61.33	35.15	40.59	45.38	50.73	55.58	60.03	33.58	38.77	43.35	48.47	53.09	57.35
THR	60	43.61	50.36	56.30	62.95	68.95	74.48	42.69	49.29	55.11	61.62	67.50	72.91	40.78	47.09	52.64	58.86	64.48	69.64
TMR	60	51.30	59.24	66.23	74.05	81.11	87.61	50.22	57.99	64.83	72.49	79.40	85.77	47.97	55.39	61.93	69.24	75.85	81.92

Note: Standard capacity is rated at 100F liquid inlet and 40F evaporator temperature; with 100 Psi pressure drop across the TXV per ARI 750-2001.

Refrigerant Liquid Temperature Valve Capacity Multiplier Correction Factors

	Refrigerant Liquid Temperature °F															
	0	10	20	30	40	50	60	70	80	90	100	110	120	130	140	
R-12 Correction Factor	1.60	1.54	1.48	1.42	1.36	1.30	1.24	1.18	1.12	1.06	1.00	.94	.88	.82	.75	
R-134a Correction Factor	1.70	1.63	1.56	1.49	1.42	1.36	1.29	1.21	1.14	1.07	1.00	.93	.85	.78	.71	
R-22 Correction Factor	1.56	1.51	1.45	1.40	1.34	1.29	1.23	1.17	1.12	1.06	1.00	.94	.88	.82	.76	
R-404A/R-507 Correction Factor	2.00	1.90	1.80	1.70	1.60	1.50	1.40	1.30	1.20	1.10	1.00	.90	.80	.70	.50	

These factors include corrections for liquid refrigerant density and net refrigerating effect and are based on an average evaporator temperature of 0°F. However, they may be used for any evaporator temperature from -40°F to +40°F since the variation in the actual factors across this range is insignificant.

R-502 Balanced Ported Valves (Tons)– HF, TFE, TRAE and T Series (cont.)

Valve Type	Nominal Rating	Evaporator Temperature																	
		0°F						-20°F					-40°F						
		Pressure Drop Across Valve (PSI)						Pressure Drop Across Valve (PSI)					Pressure Drop Across Valve (PSI)						
	60	80	100	125	150	175	80	100	125	150	175	200	80	100	125	150	175	200	
HF	1/8	0.12	0.14	0.15	0.17	0.19	0.20	0.10	0.11	0.13	0.14	0.15	0.16	0.06	0.07	0.08	0.08	0.09	0.09
HF	1/4	0.23	0.27	0.30	0.33	0.36	0.39	0.18	0.20	0.23	0.25	0.27	0.28	0.12	0.13	0.15	0.16	0.18	0.19
HF	1/2	0.42	0.48	0.54	0.61	0.66	0.72	0.33	0.37	0.41	0.45	0.49	0.52	0.21	0.23	0.26	0.29	0.31	0.33
HF	1	0.64	0.74	0.83	0.92	1.01	1.09	0.50	0.56	0.63	0.68	0.74	0.79	0.32	0.36	0.40	0.44	0.47	0.51
HF	1-1/4	0.86	0.99	1.11	1.24	1.36	1.47	0.68	0.76	0.85	0.93	1.01	1.08	0.43	0.48	0.54	0.59	0.64	0.68
HF	1-1/2	1.10	1.27	1.42	1.59	1.74	1.88	0.87	0.97	1.09	1.19	1.29	1.38	0.55	0.61	0.69	0.75	0.81	0.87
HF	2	1.46	1.69	1.88	2.11	2.31	2.49	1.15	1.29	1.44	1.57	1.70	1.82	0.73	0.82	0.91	1.00	1.08	1.15
HF	3-1/2	2.59	2.99	3.34	3.74	4.10	4.42	1.65	1.84	2.06	2.26	2.44	2.61	1.30	1.45	1.63	1.78	1.92	2.06
HF	5	3.60	4.16	4.65	5.20	5.69	6.15	2.84	3.18	3.55	3.89	4.20	4.49	1.81	2.02	2.26	2.48	2.68	2.86
HF	7	4.56	5.27	5.89	6.58	7.21	7.79	3.60	4.02	4.50	4.93	5.32	5.69	2.29	2.56	2.86	3.14	3.39	3.62
HF	10	6.76	7.81	8.73	9.76	10.69	11.54	5.34	5.97	6.68	7.31	7.90	8.44	3.40	3.80	4.25	4.66	5.03	5.38
HF	13	8.90	10.28	11.49	12.85	14.07	15.20	7.03	7.86	8.79	9.63	10.40	11.12	4.48	5.01	5.60	6.13	6.63	7.08
TFE	5	3.54	4.09	4.57	5.11	5.60	6.05	2.79	3.12	3.49	3.82	4.13	4.41	1.78	1.99	2.23	2.44	2.63	2.81
TFE	7	4.84	5.59	6.25	6.99	7.65	8.27	3.82	4.27	4.78	5.23	5.65	6.04	2.43	2.72	3.04	3.33	3.59	3.84
TFE	9	6.01	6.94	7.76	8.67	9.50	10.26	4.75	5.31	5.94	6.50	7.03	7.51	3.02	3.38	3.78	4.14	4.47	4.78
TFE	14	9.18	10.60	11.85	13.25	14.51	15.68	7.25	8.11	9.06	9.93	10.72	11.46	4.61	5.15	5.76	6.31	6.82	7.29
TRAE+	8	5.20	6.00	6.71	7.51	8.22	8.88	4.11	4.60	5.14	5.63	6.08	6.50	2.62	2.93	3.28	3.59	3.88	4.14
TRAE+	12	7.58	8.75	9.79	10.94	11.99	12.95	5.99	6.70	7.49	8.20	8.86	9.47	3.81	4.26	4.76	5.22	5.64	6.02
TRAE+	14	8.47	9.78	10.93	12.23	13.39	14.47	6.69	7.48	8.36	9.16	9.89	10.58	4.26	4.76	5.33	5.83	6.30	6.74
TRAE+	20	12.83	14.81	16.56	18.52	20.29	21.91	10.13	11.33	12.66	13.87	14.98	16.02	6.45	7.21	8.06	8.83	9.54	10.20
TRAE+	30	17.64	20.37	22.77	25.46	27.89	30.13	13.93	15.57	17.41	19.07	20.60	22.03	8.87	9.92	11.09	12.15	13.12	14.02
TRAE	35	23.81	27.49	30.74	34.37	37.65	40.66	18.80	21.02	23.50	25.74	27.81	29.73	11.97	13.38	14.96	16.39	17.70	18.93
TRAE	40	25.97	29.99	33.53	37.48	41.06	44.35	20.51	22.93	25.64	28.08	30.33	32.43	13.06	14.60	16.33	17.88	19.32	20.65
TRAE	50	30.91	35.69	39.90	44.61	48.87	52.79	24.41	27.29	30.51	33.42	36.10	38.60	15.54	17.37	19.43	21.28	22.98	24.57
TJR	9	6.70	7.74	8.65	9.67	10.59	11.44	7.31	8.17	9.14	10.01	10.81	11.56	6.89	7.70	8.61	9.43	10.19	11.56
TJR	12	8.02	9.26	10.36	11.58	12.68	13.70	8.75	9.78	10.94	11.98	12.94	13.84	8.25	9.22	10.31	11.29	12.20	13.84
TER	14	10.03	11.58	12.95	14.48	15.86	17.13	10.95	12.24	13.68	14.99	16.19	17.31	10.31	11.53	12.89	14.12	15.26	17.31
TER	16	11.85	13.59	15.30	17.11	18.74	20.24	12.93	14.46	16.16	17.71	19.13	20.45	12.19	13.63	15.23	16.69	18.02	20.45
TER	21	15.96	18.43	20.60	23.03	25.23	27.26	17.14	19.47	21.76	23.84	25.75	27.53	16.41	18.35	20.51	22.47	24.27	27.53
TER	27	20.51	23.69	26.48	29.61	32.44	35.04	22.38	25.02	27.98	30.65	33.10	35.39	21.09	23.58	26.37	28.88	31.20	35.39
TIR	37	25.07	28.95	32.37	36.19	39.64	42.82	27.35	30.58	34.19	37.45	40.45	43.25	25.78	28.82	32.22	35.30	38.12	43.25
THR	48	31.90	36.84	41.19	46.05	50.44	54.49	34.81	38.92	43.51	47.66	51.48	55.04	32.80	36.67	41.00	44.92	48.52	55.04
THR	60	38.74	44.74	50.02	55.92	61.26	66.71	42.27	47.26	52.84	57.88	62.52	66.84	39.84	44.54	49.79	54.55	58.92	66.84
TMR	60	45.58	52.63	58.84	65.79	72.07	77.84	49.73	55.60	62.84	68.09	73.55	78.62	46.86	52.39	58.58	64.17	69.31	78.62

Refrigerant Liquid Temperature Valve Capacity Multiplier Correction Factors

	Refrigerant Liquid Temperature °F														
	0	10	20	30	40	50	60	70	80	90	100	110	120	130	140
R-12 Correction Factor	1.60	1.54	1.48	1.42	1.36	1.30	1.24	1.18	1.12	1.06	1.00	.94	.88	.82	.75
R-134a Correction Factor	1.70	1.63	1.56	1.49	1.42	1.36	1.29	1.21	1.14	1.07	1.00	.93	.85	.78	.71
R-22 Correction Factor	1.56	1.51	1.45	1.40	1.34	1.29	1.23	1.17	1.12	1.06	1.00	.94	.88	.82	.76
R-404A/R-507 Correction Factor	2.00	1.90	1.80	1.70	1.60	1.50	1.40	1.30	1.20	1.10	1.00	.90	.80	.70	.50

These factors include corrections for liquid refrigerant density and net refrigerating effect and are based on an average evaporator temperature of 0°F. However, they may be used for any evaporator temperature from -40°F to +40°F since the variation in the actual factors across this range is insignificant.

R-410A Balance Ported Valves (Tons) - TFE Series

Valve Type	Nominal Rating	Evaporator Temperature																							
		50 °F								40 °F								20 °F							
		Pressure Drop Across Valve (PSI)								Pressure Drop Across Valve (PSI)								Pressure Drop Across Valve (PSI)							
		75	110	140	160	210	240	285	75	110	140	160	210	240	285	75	110	140	160	210	240	285			
TFES	12	8.1	9.9	11.1	11.9	13.6	14.6	15.9	8.1	9.8	11.0	11.8	13.5	14.5	15.7	7.9	9.6	10.8	11.5	13.2	14.1	15.4			
	16	12.4	15.0	16.9	18.1	20.7	22.1	24.1	12.3	14.8	16.7	17.9	20.5	21.9	23.9	12.0	14.5	16.4	17.5	20.1	21.5	23.4			
	20	13.3	16.1	18.2	19.5	22.3	23.8	26.0	13.2	16.0	18.1	19.3	22.1	23.6	25.8	12.9	15.7	17.7	18.9	21.6	23.1	25.2			
Valve Type	Nominal Rating	Evaporator Temperature																							
		0 °F								-20 °F								-40 °F							
		Pressure Drop Across Valve (PSI)								Pressure Drop Across Valve (PSI)								Pressure Drop Across Valve (PSI)							
		75	110	140	160	210	240	285	75	110	140	160	210	240	285	75	110	140	160	210	240	285			
TFES	12	7.7	9.3	10.5	11.2	12.9	13.8	15.0	7.5	9.0	10.2	10.9	12.5	13.3	14.5	7.2	8.7	9.8	10.5	12.0	12.9	14.0			
	16	11.7	14.1	16.0	17.1	19.5	20.9	22.8	11.3	13.7	15.5	16.5	18.9	20.2	22.1	10.9	13.2	14.9	15.9	18.3	19.5	21.3			
	20	12.6	15.2	17.2	18.4	21.1	22.5	24.5	12.2	14.8	16.7	17.8	20.4	21.8	23.8	11.8	14.3	16.1	17.2	19.7	21.1	22.9			

Note: Standard capacity is rated at 100 °F liquid inlet and 40 °F evap temperature; with 160 Psi pressure drop across TXV per ARI 750-2001. These ratings assume vapor free liquid entering the thermal expansion valve.

Refrigerant Liquid Temperature Correction Factors

	Refrigerant Liquid Temperature °F									
	50	60	70	80	90	100	110	120	130	140
R-410A Correction Factor	1.37	1.30	1.23	1.15	1.08	1.00	0.92	0.84	0.75	0.65

These factors include corrections for liquid refrigerant density and net refrigeration effect and are based on an average evaporator temperature of 40 °F with maximum 7 °F change in superheat. However, they may be used for any evaporator temperature from -40 °F to +40 °F; since the variation in the actual factors across this range is insignificant.

EX2 – Pulse Modulated Electric

The EX2 is an electrically driven expansion valve designed for use with R-12, R-22, R-134a, R-404A, R-407C, and R-502.

Features

- Pulse width modulation provides very precise temperature control
- Dampened plunger reduces noise and effects of "water hammer"
- Shut off function eliminates the necessity of a separate solenoid valve

Options

- One valve body can be combined with 6 orifices to make 6 capacity ranges up to 2.7 tons R-22.



Specifications

- Designed for 15 year life or 80 million cycles at 15 sec. duty cycle
- Maximum Working Pressure: 400 psig MOPD, 500 psig
- ASC2X Coils: 24V/60Hz, 120V/60Hz
- UL/CUL file number: MP604

NOTE: This valve requires a ASC2X type coil assembly. ASC2X type coil requires cable assembly PCN:059261.

Nomenclature example: EX2 1/4 x 3/8 EXO-001 ASC2X 120V

EX2	1/4	3/8	EXO-001	ASC2X 120V
Valve Series	Inlet Connection	Outlet Connection	Orifice	Coil

Dimensional Data

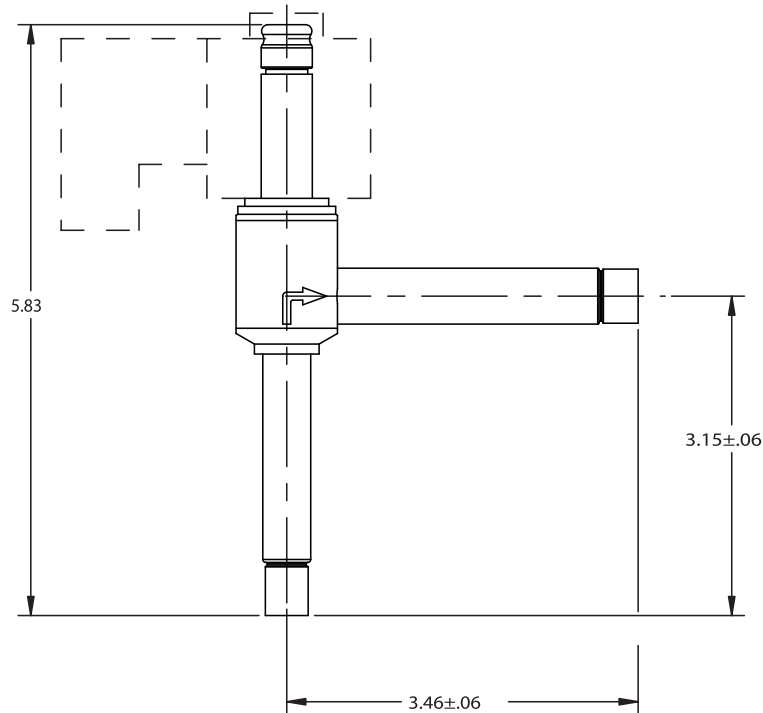

EX2 – Pulse Modulated Electric

Ordering Information

Device	Description	PCN
Electronic Expansion Valve	EX2 3/8 x 1/2	064497
24V/60Hz Coil	ASC2X 24/60	064503
120V/60Hz Coil	ASC2X 120/60	064504

Standard Product Offering

The liquid capacity table below quotes capacities at 100% duty cycle (i.e. the valve is open continuously). However, it is recommended to operate the valve at partial load (50-80%) to allow for system load fluctuations. The valve operates with a 6 second pulse width cycle. Partial capacity can be calculated by proportioning the actual pulse time relative to 6 seconds (i.e. 3 second pulse width cycle time = 50% valve capacity).

Liquid Capacity Table in Tons @ 100% Duty Cycle

PCN	Orifice #	R-134a Tons (kW)	R-22 Tons (kW)	R-404A / R-507 Tons (kW)	R-407C Tons (kW)	R-744 Tons (kW)
064570	EXO-00X	0.2 (0.7)	0.2 (0.9)	0.17 (0.6)	0.28 (1.0)	0.51 (1.8)
064569	EXO-000	0.3 (1.2)	0.4 (1.6)	0.3 (1.1)	0.48 (1.7)	0.94 (3.3)
064499	EXO-001	0.7 (2.5)	0.9 (3.2)	0.65 (2.3)	1.0 (3.5)	1.85 (6.5)
064500	EXO-002	0.9 (3.3)	1.2 (4.3)	0.85 (3.0)	1.34 (4.7)	2.47 (8.7)
064501	EXO-003	1.6 (5.6)	2.0 (7.2)	1.45 (5.1)	2.22 (7.8)	4.15 (14.6)
064502	EXO-004	2.4 (8.5)	3.1 (10.9)	2.19 (7.7)	3.36 (11.8)	6.31 (22.2)
064497	No Orifice Used	3.7 (13.3)	4.8 (17.2)	3.44 (12.1)	5.32 (18.7)	9.95 (35.0)

Nominal capacities shown in this table are based on 40°F evaporating temperature, 100°F condensing temperature and 100 psig pressure drop across the valve.

Standard Product Offering

EX2 Extended Capacity Tables

R-12 Electric Valves (Tons)– EX2

Capacities are for EX2 @ 100% duty cycle

Valve Type	Nominal Rating	Evaporator Temperature																	
		50°F						40°F						20°F					
		Pressure Drop Across Valve (PSI)						Pressure Drop Across Valve (PSI)						Pressure Drop Across Valve (PSI)					
		60	80	100	125	150	175	60	80	100	125	150	175	60	80	100	125	150	175
EX2-00X	0.23	0.14	0.27	0.30	0.33	0.36	0.39	0.14	0.16	0.18	0.20	0.22	0.24	0.13	0.15	0.17	0.19	0.21	0.22
EX2-000	0.4	0.24	0.46	0.52	0.58	0.63	0.68	0.24	0.28	0.31	0.35	0.38	0.41	0.23	0.27	0.30	0.33	0.36	0.39
EX2-001	0.81	0.49	0.94	1.05	1.17	1.28	1.38	0.48	0.55	0.62	0.69	0.76	0.82	0.46	0.53	0.59	0.66	0.73	0.79
EX2-002	1.1	0.67	1.27	1.42	1.59	1.74	1.88	0.65	0.75	0.84	0.94	1.03	1.11	0.63	0.73	0.81	0.91	1.00	1.08
EX2-003	2.0	1.21	2.31	2.58	2.89	3.16	3.42	1.19	1.37	1.54	1.72	1.88	2.03	1.14	1.32	1.47	1.65	1.80	1.95
EX2-004	2.7	1.63	3.12	3.49	3.90	4.27	4.61	1.60	1.85	2.07	2.31	2.53	2.73	1.54	1.78	1.99	2.22	2.43	2.63
EX2-M00	4.3	2.60	4.97	5.55	6.21	6.80	7.34	2.55	2.94	3.29	3.68	4.03	4.35	2.45	2.83	3.16	3.54	3.87	4.18

Valve Type	Nominal Rating	Evaporator Temperature																	
		0°F						-20°F						-40°F					
		Pressure Drop Across Valve (PSI)						Pressure Drop Across Valve (PSI)						Pressure Drop Across Valve (PSI)					
		60	80	100	125	150	175	80	100	125	150	175	200	80	100	125	150	175	200
EX2-00X	0.23	0.13	0.27	0.30	0.33	0.36	0.39	0.14	0.16	0.18	0.20	0.22	0.24	0.11	0.13	0.14	0.16	0.17	0.19
EX2-000	0.4	0.22	0.46	0.52	0.58	0.63	0.68	0.24	0.28	0.31	0.35	0.38	0.41	0.20	0.23	0.26	0.29	0.32	0.34
EX2-001	0.81	0.44	0.94	1.05	1.17	1.28	1.38	0.48	0.55	0.62	0.69	0.76	0.82	0.40	0.46	0.52	0.58	0.63	0.68
EX2-002	1.1	0.60	1.27	1.42	1.59	1.74	1.88	0.66	0.76	0.85	0.95	1.04	1.13	0.54	0.62	0.70	0.78	0.85	0.92
EX2-003	2.0	1.09	2.31	2.58	2.89	3.16	3.42	1.20	1.39	1.55	1.73	1.90	2.05	0.98	1.13	1.27	1.41	1.55	1.67
EX2-004	2.7	1.47	3.12	3.49	3.90	4.27	4.61	1.40	1.62	1.81	2.02	2.21	2.39	1.33	1.54	1.72	1.92	2.10	2.27
EX2-M00	4.3	2.34	4.97	5.55	6.21	6.80	7.34	2.57	2.97	3.32	3.71	4.06	4.39	2.12	2.45	2.74	3.06	3.35	3.62

R-22 Electric Valves (Tons)– EX2

Capacities are for EX2 @ 100% duty cycle

Valve Type	Nominal Rating	Evaporator Temperature																	
		50°F						40°F						20°F					
		Pressure Drop Across Valve (PSI)						Pressure Drop Across Valve (PSI)						Pressure Drop Across Valve (PSI)					
		60	80	100	125	150	175	60	80	100	125	150	175	60	80	100	125	150	175
EX2-00X	0.23	0.18	0.21	0.23	0.26	0.28	0.31	0.18	0.21	0.23	0.26	0.28	0.31	0.17	0.20	0.22	0.25	0.27	0.29
EX2-000	0.4	0.31	0.36	0.40	0.45	0.49	0.53	0.31	0.36	0.40	0.45	0.49	0.53	0.30	0.35	0.39	0.43	0.47	0.51
EX2-001	0.81	0.64	0.74	0.83	0.92	1.01	1.09	0.63	0.73	0.81	0.91	1.00	1.08	0.61	0.70	0.79	0.88	0.96	1.04
EX2-002	1.1	0.86	0.99	1.11	1.24	1.36	1.47	0.85	0.98	1.10	1.23	1.34	1.45	0.83	0.96	1.07	1.20	1.31	1.42
EX2-003	2.0	1.57	1.81	2.03	2.27	2.48	2.68	1.55	1.79	2.00	2.24	2.45	2.65	1.51	1.74	1.95	2.18	2.39	2.58
EX2-004	2.7	2.12	2.45	2.74	3.06	3.35	3.62	2.10	2.42	2.71	3.03	3.32	3.59	2.04	2.36	2.63	2.94	3.23	3.48
EX2-M00	4.3	3.38	3.90	4.36	4.88	5.34	5.77	3.34	3.86	4.31	4.82	5.28	5.70	3.25	3.75	4.20	4.69	5.14	5.55

Valve Type	Nominal Rating	Evaporator Temperature																	
		0°F						-20°F						-40°F					
		Pressure Drop Across Valve (PSI)						Pressure Drop Across Valve (PSI)						Pressure Drop Across Valve (PSI)					
		60	80	100	125	150	175	80	100	125	150	175	200	80	100	125	150	175	200
EX2-00X	0.23	0.17	0.20	0.22	0.25	0.27	0.29	0.19	0.21	0.24	0.26	0.28	0.30	0.18	0.20	0.23	0.25	0.27	0.28
EX2-000	0.4	0.29	0.33	0.37	0.42	0.46	0.50	0.33	0.37	0.41	0.45	0.49	0.52	0.32	0.36	0.40	0.44	0.47	0.51
EX2-001	0.81	0.60	0.69	0.77	0.87	0.95	1.02	0.67	0.75	0.84	0.92	0.99	1.06	0.64	0.72	0.80	0.88	0.95	1.01
EX2-002	1.1	0.81	0.94	1.05	1.17	1.28	1.38	0.90	1.01	1.13	1.23	1.33	1.42	0.87	0.97	1.09	1.19	1.29	1.38
EX2-003	2.0	1.47	1.70	1.90	2.12	2.32	2.51	1.64	1.83	2.05	2.25	2.43	2.59	1.59	1.78	1.99	2.18	2.35	2.51
EX2-004	2.7	1.99	2.30	2.57	2.87	3.15	3.40	2.22	2.48	2.78	3.04	3.28	3.51	2.14	2.39	2.68	2.93	3.17	3.38
EX2-M00	4.3	3.16	3.65	4.08	4.56	5.00	5.40	3.54	3.96	4.43	4.85	5.24	5.60	3.42	3.82	4.28	4.68	5.06	5.41

EX2 Extended Capacity Tables

R-134a Electric Valves (Tons)– EX2

Capacities are for EX2 @ 100% duty cycle

Valve Type	Nominal Rating	Evaporator Temperature																	
		50°F						40°F					20°F						
		Pressure Drop Across Valve (PSI)						Pressure Drop Across Valve (PSI)					Pressure Drop Across Valve (PSI)						
	60	80	100	125	150	175	60	80	100	125	150	175	60	80	100	125	150	175	
EX2-00X	0.23	0.17	0.20	0.22	0.25	0.27	0.29	0.17	0.20	0.22	0.25	0.27	0.29	0.16	0.18	0.21	0.23	0.25	0.27
EX2-000	0.4	0.30	0.35	0.39	0.43	0.47	0.51	0.29	0.33	0.37	0.42	0.46	0.50	0.28	0.32	0.36	0.40	0.44	0.48
EX2-001	0.81	0.61	0.70	0.79	0.88	0.96	1.04	0.59	0.68	0.76	0.85	0.93	1.01	0.57	0.66	0.74	0.82	0.90	0.97
EX2-002	1.1	0.82	0.95	1.06	1.18	1.30	1.40	0.81	0.94	1.05	1.17	1.28	1.38	0.77	0.89	0.99	1.11	1.22	1.32
EX2-003	2.0	1.55	1.79	2.00	2.24	2.45	2.65	1.52	1.76	1.96	2.19	2.40	2.60	1.47	1.70	1.90	2.12	2.32	2.51
EX2-004	2.7	2.02	2.33	2.61	2.92	3.19	3.45	1.98	2.29	2.56	2.86	3.13	3.38	1.90	2.19	2.45	2.74	3.00	3.24
EX2-M00	4.3	3.22	3.72	4.16	4.65	5.09	5.50	3.16	3.65	4.08	4.56	5.00	5.40	3.02	3.49	3.90	4.36	4.78	5.16

Valve Type	Nominal Rating	Evaporator Temperature																	
		0°F						-20°F					-40°F						
		Pressure Drop Across Valve (PSI)						Pressure Drop Across Valve (PSI)					Pressure Drop Across Valve (PSI)						
	60	80	100	125	150	175	80	100	125	150	175	200	80	100	125	150	175	200	
EX2-00X	0.23	0.15	0.17	0.19	0.22	0.24	0.26	0.17	0.19	0.21	0.23	0.25	0.27	0.16	0.18	0.20	0.22	0.24	0.25
EX2-000	0.4	0.27	0.31	0.35	0.39	0.43	0.46	0.29	0.32	0.36	0.40	0.43	0.46	0.28	0.31	0.35	0.38	0.41	0.44
EX2-001	0.81	0.54	0.62	0.70	0.78	0.85	0.92	0.59	0.66	0.74	0.81	0.87	0.93	0.56	0.63	0.70	0.77	0.83	0.89
EX2-002	1.1	0.74	0.85	0.96	1.07	1.17	1.26	0.81	0.91	1.01	1.11	1.20	1.28	0.76	0.85	0.95	1.04	1.12	1.20
EX2-003	2.0	1.41	1.63	1.82	2.04	2.23	2.41	1.56	1.74	1.95	2.14	2.31	2.47	1.49	1.67	1.86	2.04	2.20	2.36
EX2-004	2.7	1.81	2.09	2.34	2.61	2.86	3.09	1.98	2.21	2.48	2.71	2.93	3.13	1.88	2.10	2.35	2.57	2.78	2.97
EX2-M00	4.3	2.88	3.33	3.72	4.16	4.55	4.92	3.16	3.53	3.95	4.33	4.67	5.00	2.99	3.34	3.74	4.09	4.42	4.73

R-404A/R-507 Electric Valves (Tons)– EX2

Capacities are for EX2 @ 100% duty cycle

Valve Type	Nominal Rating	Evaporator Temperature																	
		50°F						40°F					20°F						
		Pressure Drop Across Valve (PSI)						Pressure Drop Across Valve (PSI)					Pressure Drop Across Valve (PSI)						
	60	80	100	125	150	175	60	80	100	125	150	175	60	80	100	125	150	175	
EX2-00X	0.23	0.13	0.15	0.17	0.19	0.21	0.22	0.13	0.15	0.17	0.19	0.21	0.22	0.12	0.14	0.15	0.17	0.19	0.20
EX2-000	0.4	0.23	0.27	0.30	0.33	0.36	0.39	0.22	0.25	0.28	0.32	0.35	0.38	0.21	0.24	0.27	0.30	0.33	0.36
EX2-001	0.81	0.47	0.54	0.61	0.68	0.74	0.80	0.46	0.53	0.59	0.66	0.73	0.79	0.43	0.50	0.56	0.62	0.68	0.73
EX2-002	1.1	0.63	0.73	0.81	0.91	1.00	1.08	0.62	0.72	0.80	0.89	0.98	1.06	0.59	0.68	0.76	0.85	0.93	1.01
EX2-003	2.0	1.15	1.33	1.48	1.66	1.82	1.96	1.12	1.29	1.45	1.62	1.77	1.91	1.07	1.24	1.38	1.54	1.69	1.83
EX2-004	2.7	1.55	1.79	2.00	2.24	2.45	2.65	1.52	1.76	1.96	2.19	2.40	2.60	1.44	1.66	1.86	2.08	2.28	2.46
EX2-M00	4.3	2.47	2.85	3.19	3.57	3.91	4.22	2.42	2.79	3.12	3.49	3.83	4.13	2.30	2.66	2.97	3.32	3.64	3.93

Valve Type	Nominal Rating	Evaporator Temperature																	
		0°F						-20°F					-40°F						
		Pressure Drop Across Valve (PSI)						Pressure Drop Across Valve (PSI)					Pressure Drop Across Valve (PSI)						
	60	80	100	125	150	175	80	100	125	150	175	200	80	100	125	150	175	200	
EX2-00X	0.23	0.12	0.14	0.15	0.17	0.19	0.20	0.13	0.15	0.16	0.18	0.19	0.21	0.12	0.13	0.15	0.16	0.18	0.19
EX2-000	0.4	0.20	0.23	0.26	0.29	0.32	0.34	0.22	0.25	0.28	0.30	0.33	0.35	0.20	0.22	0.25	0.27	0.30	0.32
EX2-001	0.81	0.41	0.47	0.53	0.59	0.65	0.70	0.44	0.49	0.55	0.60	0.65	0.70	0.41	0.46	0.51	0.56	0.61	0.65
EX2-002	1.1	0.55	0.64	0.71	0.79	0.87	0.94	0.60	0.67	0.75	0.82	0.89	0.95	0.56	0.63	0.70	0.77	0.83	0.89
EX2-003	2.0	1.01	1.17	1.30	1.46	1.60	1.72	1.09	1.22	1.36	1.49	1.61	1.72	1.02	1.14	1.28	1.40	1.51	1.61
EX2-004	2.7	1.36	1.57	1.76	1.96	2.15	2.32	1.48	1.65	1.85	2.03	2.19	2.34	1.38	1.54	1.73	1.89	2.04	2.18
EX2-M00	4.3	2.17	2.51	2.80	3.13	3.43	3.71	2.35	2.63	2.94	3.22	3.48	3.72	2.19	2.45	2.74	3.00	3.24	3.46

EX2 Extended Capacity Tables

R-407C Electric Valves (Tons)– EX2

Capacities are for EX2 @ 100% duty cycle

Valve Type	Nominal Rating	Evaporator Temperature																	
		50°F					40°F					20°F							
		Pressure Drop Across Valve (PSI)					Pressure Drop Across Valve (PSI)					Pressure Drop Across Valve (PSI)							
		60	80	100	125	150	175	60	80	100	125	150	175	60	80	100	125	150	175
EX2-00X	0.23	0.17	0.20	0.22	0.25	0.27	0.29	0.17	0.20	0.22	0.25	0.27	0.29	0.16	0.18	0.21	0.23	0.25	0.27
EX2-000	0.4	0.30	0.35	0.39	0.43	0.47	0.51	0.30	0.35	0.39	0.43	0.47	0.51	0.28	0.32	0.36	0.40	0.44	0.48
EX2-001	.81	0.61	0.70	0.79	0.88	0.96	1.04	0.60	0.69	0.77	0.87	0.95	1.02	0.58	0.67	0.75	0.84	0.92	0.99
EX2-002	1.1	0.83	0.96	1.07	1.20	1.31	1.42	0.81	0.94	1.05	1.17	1.28	1.38	0.78	0.90	1.01	1.13	1.23	1.33
EX2-003	2.0	1.51	1.74	1.95	2.18	2.39	2.58	1.48	1.71	1.91	2.14	2.34	2.53	1.42	1.64	1.83	2.05	2.25	2.43
EX2-004	2.7	2.04	2.36	2.63	2.94	3.23	3.48	2.00	2.31	2.58	2.89	3.16	3.42	1.92	2.22	2.48	2.77	3.04	3.28
EX2-M00	4.3	3.24	3.74	4.18	4.68	5.12	5.53	3.18	3.67	4.11	4.59	5.03	5.43	3.06	3.53	3.95	4.42	4.84	5.23

Valve Type	Nominal Rating	Evaporator Temperature																	
		0°F					-20°F					-40°F							
		Pressure Drop Across Valve (PSI)					Pressure Drop Across Valve (PSI)					Pressure Drop Across Valve (PSI)							
		60	80	100	125	150	175	80	100	125	150	175	200	80	100	125	150	175	200
EX2-00X	0.23	0.16	0.18	0.21	0.23	0.25	0.27	0.17	0.19	0.21	0.23	0.25	0.27	0.16	0.18	0.20	0.22	0.24	0.25
EX2-000	0.4	0.27	0.31	0.35	0.39	0.43	0.46	0.30	0.34	0.38	0.41	0.44	0.47	0.28	0.31	0.35	0.38	0.41	0.44
EX2-001	.81	0.55	0.64	0.71	0.79	0.87	0.94	0.60	0.67	0.75	0.82	0.89	0.95	0.57	0.64	0.71	0.78	0.84	0.90
EX2-002	1.1	0.75	0.87	0.97	1.08	1.19	1.28	0.82	0.92	1.03	1.12	1.21	1.30	0.78	0.87	0.98	1.07	1.15	1.23
EX2-003	2.0	1.36	1.57	1.76	1.96	2.15	2.32	1.49	1.67	1.86	2.04	2.20	2.36	1.42	1.59	1.78	1.94	2.10	2.25
EX2-004	2.7	1.83	2.11	2.36	2.64	2.89	3.13	2.02	2.26	2.53	2.77	2.99	3.19	1.91	2.14	2.39	2.62	2.82	3.02
EX2-M00	4.3	2.92	3.37	3.77	4.21	4.62	4.99	3.21	3.59	4.01	4.40	4.75	5.08	3.05	3.41	3.81	4.18	4.51	4.82

R-502 Electric Valves (Tons)– EX2

Capacities are for EX2 @ 100% duty cycle

Valve Type	Nominal Rating	Evaporator Temperature																	
		50°F					40°F					20°F							
		Pressure Drop Across Valve (PSI)					Pressure Drop Across Valve (PSI)					Pressure Drop Across Valve (PSI)							
		60	80	100	125	150	175	60	80	100	125	150	175	60	80	100	125	150	175
EX2-000	0.4	0.21	0.24	0.27	0.30	0.33	0.36	0.20	0.23	0.26	0.29	0.32	0.34	0.19	0.22	0.25	0.27	0.30	0.32
EX2-001	.81	0.42	0.48	0.54	0.61	0.66	0.72	0.41	0.47	0.53	0.59	0.65	0.70	0.39	0.45	0.50	0.56	0.62	0.67
EX2-002	1.1	0.56	0.65	0.72	0.81	0.89	0.96	0.55	0.64	0.71	0.79	0.87	0.94	0.53	0.61	0.68	0.76	0.84	0.91
EX2-003	2.0	1.03	1.19	1.33	1.49	1.63	1.76	1.00	1.15	1.29	1.44	1.58	1.71	0.96	1.11	1.24	1.39	1.52	1.64
EX2-004	2.7	1.39	1.61	1.79	2.01	2.20	2.37	1.36	1.57	1.76	1.96	2.15	2.32	1.29	1.49	1.67	1.86	2.04	2.20
EX2-M00	4.3	2.21	2.55	2.85	3.19	3.49	3.77	2.16	2.49	2.79	3.12	3.42	3.69	2.06	2.38	2.66	2.97	3.26	3.52

Valve Type	Nominal Rating	Evaporator Temperature																	
		0°F					-20°F					-40°F							
		Pressure Drop Across Valve (PSI)					Pressure Drop Across Valve (PSI)					Pressure Drop Across Valve (PSI)							
		60	80	100	125	150	175	80	100	125	150	175	200	80	100	125	150	175	200
EX2-000	0.4	0.18	0.21	0.23	0.26	0.28	0.31	0.20	0.22	0.25	0.27	0.30	0.32	0.19	0.21	0.24	0.26	0.28	0.30
EX2-001	.81	0.37	0.43	0.48	0.53	0.59	0.63	0.40	0.45	0.50	0.55	0.59	0.63	0.38	0.42	0.48	0.52	0.56	0.60
EX2-002	1.1	0.50	0.58	0.65	0.72	0.79	0.85	0.55	0.61	0.69	0.75	0.81	0.87	0.51	0.57	0.64	0.70	0.75	0.81
EX2-003	2.0	0.91	1.05	1.17	1.31	1.44	1.55	0.99	1.11	1.24	1.36	1.46	1.57	0.93	1.04	1.16	1.27	1.38	1.47
EX2-004	2.7	1.23	1.42	1.59	1.78	1.94	2.10	1.34	1.50	1.68	1.83	1.98	2.12	1.26	1.41	1.58	1.73	1.86	1.99
EX2-M00	4.3	1.96	2.26	2.53	2.83	3.10	3.35	2.13	2.38	2.66	2.92	3.15	3.37	2.00	2.24	2.50	2.74	2.96	3.16

EX4-EX8 Electrical Control Valve

R-410A

The EX4-EX8 are stepper motor driven valves that are optimized for the control of liquid or gaseous mass flow in refrigeration systems. Multifunction capability as expansion valve, hot gas bypass, suction gas throttling, head pressure, liquid line actuator and other applications systems.

Features

- Fully hermetic design
- Fast full stroke time
- Applicable to all common refrigerants (HCFC, HFC), for subcritical CO₂ applications
- High resolution and excellent repeatability
- Bi-flow versions for heat pump applications
- Positive shut-off function to eliminate the use of an additional solenoid valve
- Linear flow capacity
- Wide capacity range (10 - 100%)
- Continuous modulation of mass flow, no stress (liquid hammering) in the refrigeration circuit
- Direct coupling of motor and valve for high reliability (no gear mechanism)
- Ceramic slide and port for accurate flow and minimal wear
- Balanced force design
- Corrosion resistant stainless steel body, and connections



Specifications

- CE marking: EX4/EX5: not required
EX6-EX8: required, Cat I, Module A
- MOPD: EX4-EX6: 580 psid
EX7: 507 psid
EX8: 435 psid
- MWP: EX4-EX7: 870 psig
EX8: 650 psig
- Ambient temperature: -40°F to +130°F
- Humidity: 5 to 95% R.H.
- External leakage: ≤ 0.1 oz/yr (R-22)
- Stepper motor type: Bi-polar, phase current by chopper control (constant current)
- Electrical connection: 4 pin terminal via plug
- Driver supply voltage: Recommended: 24 VDC
Range: 18-36 VDC
- Phase current (operating): EX4-EX6: 500 mA max
EX7: 750 mA
EX8: 800 mA
- Holding current: EX4-EX6: 100 mA
EX7: 250 mA
EX8: 500 mA
- Nominal input power per phase: EX4-EX6: 3.5W
EX7-EX8: 5W
- Phase inductance: EX4-EX6: 30 mH ±25%
EX7: 20 mH ±25%
EX8: 22 mH ±25%
- Step mode: 2 phase full step
- Step angle: 1.8° per step ±8%
- Total number of steps: EX4-EX6: 750 full steps
EX7: 1600 full steps
EX8: 2600 full steps
- Stepping rate: 500 Hz
- Winding resistance per phase: EX4-EX6: 13 ohm ±10%
EX7: 8 ohm ±10%
EX8: 6 ohm ±10%
- Full travel time: EX4-EX6: 1.5 seconds
EX7: 3.2 seconds
EX8: 5.2 seconds

Valve Type	Inlet x Outlet (ODF)	B	C	D	E	H1	H2
EX4-I21	3/8" x 5/8"	0.3	1.8	2.2	0.4	4.4	1.0
EX5-U21	5/8" x 7/8"	0.4	2.2	2.6	0.6	4.4	1.0
EX6-I21	7/8" x 1-1/8"	0.6	2.6	3.0	0.7	4.4	1.0
EX7-I21	1-1/8" x 1-3/8"	0.8	3.1	3.2	0.9	6.2	1.7
EX8-I21	1-5/8" x 1-5/8"	0.8	3.1	3.1	0.8	7.9	2.2

Dimensional Data (in)

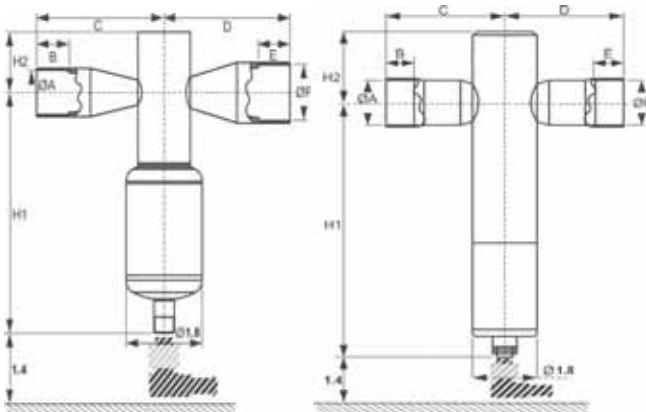

EX4-EX8 Electrical Control Valve

EX4/EX5/EX6/EX7/EX8

Nominal capacities as expansion valves and liquid injection valves

Nominal Capacities in Tons (10% - 100%)

Valve Type	R-407C	R-22	R-134a	R-404A	R-410A	R-23	R-124	R-744
EX4	.6 – 5	.6 – 4.7	.3 – 3.6	.3 – 3.3	.6 – 5.5	.6 – 5.1	.3 – 2.6	.9 – 9.5
EX5	1.4 – 15.1	1.4 – 14.2	1.1 – 11.1	1.1 – 10	1.7 – 16.5	1.4 – 15.4	.9 – 8	2.8 – 29
EX6	4.3 – 35.8	4.3 – 34.1	2.8 – 26.4	2.8 – 23.9	4.3 – 39.8	3.7 – 37	2 – 19.1	6.8 – 69.4
EX7	10 – 98.7	10 – 93.8	7.1 – 72.5	7.1 – 65.4	11.4 – 109.5	-	-	19.9 – 190.5
EX8	28.4 – 263	25.6 – 250.2	19.9 – 193.4	17.1 – 174.3	28.4 – 292	-	-	51.2 – 508.7

Note 1: EX Bi-flow versions are not released for use with R-124 and R-23 refrigerants.

Note 2: EX Bi-flow versions have identical capacity in both flow direction.

Refrigerant	Evaporating Temperature	Condensing Temperature	Subcooling
R-22, R-134a, R-404A, R-410A	+40 °F	+100°F	2°F
R-407C	+40°F dew point	+100°F bubble	2°F
R-124	+68°F	+176°F	2°F
R-23	-76°F	-13°F	2°F
R-744	-40°F	14°F	2°F

The nominal capacity is based on the following conditions:

Ordering Information

Description	Type	Inlet Connection (in)	Outlet Connection (in)	Reference #	PCN
EX4 Electrical Control Valve	EX4-I21	3/8	5/8	800615	097719
EX5 Electrical Control Valve	EX5-U21	5/8	7/8	800618	097720
EX6 Electrical Control Valve	EX6-I21	7/8	1 1/8	800620	097721
EX7 Electrical Control Valve	EX7-I21	1 1/8	1 3/8	800624	097722
EX8 Electrical Control Valve	EX8-I21	1 5/8	1 5/8	804631	097723
EX4 Bi-Flow Electrical Control Valve	EX4-U31	5/8	5/8	800617	097756
EX5 Bi-Flow Electrical Control Valve	EX5-U31	7/8	7/8	800619	097729
EX6 Bi-Flow Electrical Control Valve	EX6-I31	1 1/8	1 1/8	800622	097757
EX7 Bi-Flow Electrical Control Valve	EX7-U31	1 3/8	1 3/8	800626	097758
Valve Connector Cable	EXV-M60	N/A	N/A	804665	097741

Standard Product Offering

EXD-U00 Universal Driver Module

The EXD-U00 is a universal driver that enables the operation of Emerson stepper motor driven valves used in applications such as solenoid valves, electronic expansion valves, hot gas bypass or evaporator pressure regulator as capacity control, crankcase pressure regulator, heat reclaim regulator, and liquid level control.

Features

- Valve opening is proportional to 4-20mA or 0-10V analog input signal
- Plug and play, no parameter settings required
- Digital input can be used to force valve closing
- Dip-switches for selection of EX control valve type, analog input and start mode

Ordering Information

Description	Type	Reference #	PCN
Universal Driver Module	EXD-U00	804557	097710
Electrical Terminal Kit	K09-U00	804559	097711

Standard Product Offering

Dimensional Data (in)

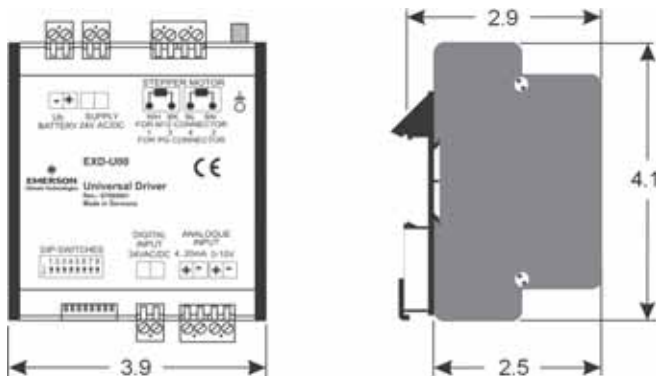

Specifications

- Supply voltage: 24V AC $\pm 10\%$, 50-60HZ, 24V DC $\pm 10\%$
- Supply current: To be protected by a 0.8A external fuse
- Power consumption: 10VA in conjunction with EX valve
- Temperature: Storage: -5°F to $+150^{\circ}\text{F}$
Operating: 32°F to $+140^{\circ}\text{F}$
- Humidity: $< 90\%$ R.H. non condensing
- Approvals: EMC EN 61326-1, EN50081, EN50082
- Marking: CE
- Input analogue signal: 4-20 mA
Burden $364\ \Omega$
0-10V
Impedence $27\text{K}\Omega$
- Digital input: 24V AC $\pm 10\%$, 50-60Hz, 24V DC $\pm 10\%$
- Connection to EX4-8: Via 4 wires cable, maximum 6m length
AWG 20/22
- Connector: Screw terminals for wire size 12/20 AWG
- Mounting: DIN rail mounted
- Housing: Aluminum

EC3-X32 Superheat Controller

The EC3 is a stand-alone universal superheat controller for stable superheat control with stepper motor driven electronic control valves and is used for air conditioning, refrigeration and industrial applications such as chillers, industrial process cooling rooftops, heat pumps, package units, close controls, cold room, food process and air driers. With the EC3-X32, parameters can be downloaded through ECD-002 or through TCP/IP compatible interface.

Features

- Superheat control in conjunction with Emerson stepper motor driven electrical control valves EX4-EX8
- Limitation of evaporating pressure (MOP)
- Low and high superheat alarm
- Low pressure switch function/alarm
- Freeze protection function/alarm
- Pump down function
- Monitoring of sensors and sensor wiring and detection of sensor and wiring failures
- Intelligent alarm management to protect the compressor, i.e fail safe operation
- Integral rechargeable battery to close EX control valves in case of power loss.
- Support of TCP/IP Ethernet technology with WebServer functionality allows monitoring and configuration of controllers through a standard WebBrowser
- Electrical connection via plug-in type screw terminal
- Aluminum housing for DIN rail mounting

Ordering Information

Description	Type	Reference #	PCN
Superheat Controller	EC3-X32	807782	097708
Terminal Kit	K03-X32	807644	097709
Temperature Sensor	ECN-N60	804497	097714
Electrical Control Valve	EX4-EX8**	**	**
Pressure Sensors (R-22/R-124/R-134a/R-404A/R-407C/R507C)	PT5-07M	802350	097748
Pressure Sensor (R-410A)	PT5-18M	802851	097749
Pressure Sensor (R-744)	PT5-30M	802352	097753
Plug and Cable Assembly for Pressure Sensor	PT4-M60	804805	097717
Optional Display/Keypad	ECD-002	807657	097712
Cable Connection between EC3-X32 and ECD-002	ECC-N30 or any standard Cat 5 patch cord with RJ45 connectors	807861	097713
Replacement Battery	EC3	807790	097693

**For further details refer to the EX4-EX8 product page.

Standard Product Offering



Specifications

- Supply voltage: 24VAC \pm 10%, 50/60 Hz
- Digital input: 24VAC \pm 10%, 50-60 Hz, 24VDC \pm 10%
- Power consumption: 25 VA max. including connected EX valve and display/keyboard
- Internal battery charging time: Approx. 2 hours if battery is fully empty
- Plug-in connector size: Removable screw version, wire size 12-20 AWG
- Ground connection: 1/4 in. spade earth connector
- Applied directive: EMC, LVD, RoHS (EN 61326, EN 50081, EN 61000-6-2, EN 61000-4-2, EN 61000-4-3, EN 610004-4, EN61000-4-5, EN 61000-4-6, EN 61000-4-11)
- Marking: CE
- Temperatures: Storage, -5°F, to +150°F
Operating, 32°F, to +140°F
- Humidity: 0 – 80% R.H. non condensing

Dimensional Data



EC3-X33 Superheat Controller

The EC3 is a stand-alone universal superheat controller for stable superheat control with stepper motor driven electronic control valves and is used for air conditioning, refrigeration and industrial applications such as chillers, industrial process cooling rooftops, heat pumps, package units, close controls, cold room, food process and air driers. The EC3-X33 requires the use of the ECD-002 display key pad unit for setting up the controller.

Features

- Superheat control in conjunction with Emerson stepper motor driven electrical control valves EX4-EX8
- Limitation of evaporating pressure (MOP)
- Low and high superheat alarm
- Monitoring of sensors and sensor wiring and detection of sensor and wiring failures
- Intelligent alarm management to protect the compressor, i.e fail safe operation
- Integral rechargeable battery to close EX control valves in case of power loss.
- Electrical connection via plug-in type screw terminal
- Aluminum housing for DIN rail mounting



Specifications

- Supply Voltage: 24VAC \pm 10%, 50/60 Hz
- Digital Input: 24VAC \pm 10%, 50-60 Hz, 24VDC \pm 10%
- Power Consumption: 25 VA max. including connected EX valve and display/keypad
- Internal battery charging time: Approx. 2 hours if battery is fully empty
- Plug-in connector size: Removable screw version wire size 12-20 AWG
- Ground connection: 1.4 in. spade earth connector
- Applied Directive: EMC, LVD, RoHS
EN 61326, EN 50081, EN 61000-6-2, EN 61000-4-2, EN 61000-4-3, EN 610004-4, EN61000-4-5, EN 61000-4-6, EN 61000-4-11)
- Marking: CE
- Temperatures: Storage: -5°F to +150°F
Operating: 32°F to +140°F
- Humidity: 0 – 80% R.H. non condensing

Ordering Information

Description	Type	Reference #	PCN
Superheat Controller	EC3-X33	807783	097707
Temperature Sensor	ECN-N60	804497	097714
Electrical Control Valve	EX4-EX8**	**	**
Pressure Sensors (R-22/R-124/R-134a/R-404A/R-407C/R507C)	PT5-07M	802350	097748
Pressure Sensor (R-410A)	PT5-18M	802851	097749
Pressure Sensor (R-744)	PT5-30M	802352	097753
Plug and Cable Assembly for Pressure Sensor	PT4-M60	804805	097717
Optional Display/Keypad	ECD-002	807657	097712
Cable Connection between EC3-X33 and ECD-002	ECC-N30 or any standard Cat 5 patch cord with RJ45 connectors	807861	097713
Replacement Battery	EC3	807790	097693

**For further details refer to the EX4-EX8 product page.

Standard Product Offering

Dimensional Data



EC3-D72 Digital Superheat Controller

For stable superheat control with EX4...EX6 electrical control valves and automatic synchronization of the PWM capacity control valve incorporated into the Copeland Scroll Digital™ compressor technology

Features

- Limitation of evaporating pressure (MOP)
- Feed-through of 4 ... 20mA signal of evaporating pressure transmitter to operate third party controllers with a common pressure transmitter
- Intelligent alarm management, superheat alarm
- Monitoring of sensors and sensor wiring, detection of sensor and wiring failures
- Integral rechargeable battery to close Electrical Control Valve in case of power loss
- Electrical connection via plug-in type screw terminals
- Aluminum housing for DIN rail mounting
- Synchronization of the PWM solenoid valve used for variable capacity control of the Copeland Scroll Digital

Additional features

EC3-X32 and EC3-D72 with TCP/IP

- WebServer functionality allows monitoring and configuration of controllers through a standard WebBrowser (e.g. Internet Explorer®)
- Internal data logging and alarm messaging by email
- Multiple language support (EmersonClimate.com)
- Freeze protection
- Low and high superheat alarm
- Low pressure switch function/Alarm

Ordering Information

Description	TCP/IP		
	Type	Reference #	PCN
Digital Superheat Controller (TCP/IP)	EC3-D72	807805	097733
Terminal Kit for EC3-D72/-D73	K03-331	807648	097734
Replacement Battery for EC3		807790	097693



Thermal
Expansion Valves

TXV Extended
Capacity Tables

EX Valves
and Controls

Solenoid Valves
and Coils

Solenoid Capacity
Tables

Industrial Solenoid
Valves

Shut Off
Valves

System
Protectors

System Protectors
Capacity Tables

Oil
Controls

Temperature
Pressure Controls

ECD-002 Display Unit

The ECD-002 is a display/keypad unit necessary for setting up controllers.

Features

- Front panel mounted interface for parameter and status read-out and for controller setup via keypad
- Indicator LEDs for valve opening/closing, demand and alarm



Specifications

- Supply: From EC3 Series controller via connecting cable
- LED indicators: Valve opening, valve closing, alarm, demand
- Display LED: Segmented display, 2-1/2 digits with automatic decimal point between ± 19.9 , switchable between $^{\circ}\text{C}$ and $^{\circ}\text{F}$
- Connecting cable: ECC-N30 or standard CAT5 patch cord with RJ45 connectors
- Temperatures: Storage, -5°F to $+150^{\circ}\text{F}$
Operating, 32°F to $+140^{\circ}\text{F}$
- Humidity: 0 - 80% R.H. non condensing
- Mounting: Panel mount (2.8 x 1.1 inch cutout)

Ordering Information

Description	Device	Reference #	PCN
Optional Display/Keypad	ECD-002	807657	097712
Cable Connection between EC3-X33 and ECD-002	ECC-N30 or any standard Cat 5 patch cord with RJ45 connectors	807861	097713

Standard Product Offering

Dimensional Data

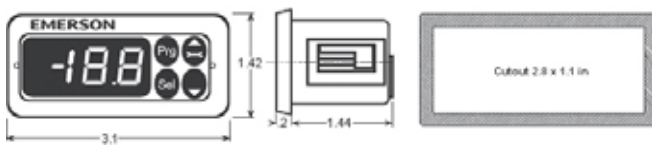

Pressure Transmitters

The Pressure Transmitters convert a pressure into a linear electric output signal. At the heart of the transmitter there is a piezo resistive chip enclosed in an oil capsule.

R-410A



Features

- Pressure sensitive piezo-based cell with strong primary output signal for precise operation
- Compact dimensions
- Vibration, shock and pulsation resistant
- Reduced full scale error over complete temperature range
- Sealed gauge absolute pressure reference for increased accuracy independent of atmospheric pressure variation
- Output signal is 4 to 20 mA
- Calibrated for specific temperature and pressure ranges to fulfill application demands in air conditioning and refrigeration systems
- Easy-to-install M12 electrical connection with pre-assembled cable assembly
- Pressure connector 7/16-20 UNF with Schrader valve

Dimensional Data (in)

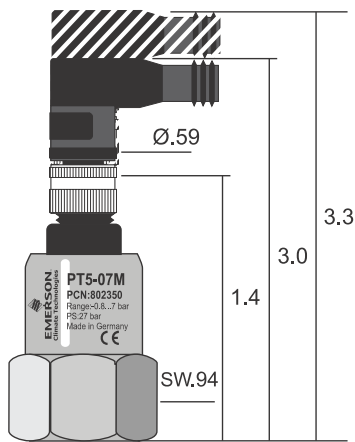

Specifications

- Supply voltage: Nominal 24 VDC
Range (polarity protected) 7 – 30 VDC
- Permissible noise & ripple: < 1 V_{p-p}
- Influence of supply voltage: < 0.02 % FS/V
- Operating current: 4 to 20 mA output, Max. ≤ 24 mA
- Load resistance: RL ≤ Ub-8.0V 0.02A
- Mounting position: Non-position sensitive
- Response time: <5 ms
- Temperatures: Ambient: -40°F to +176°F
Medium: -58°F to +275°F
Storage: -40°F to +185°F
- Sensor Life: ≥10,000,000 cycles full stroke at 77°F
- Burst Pressure: -07M = 2,176 psi
-18M and -30M = 3,626 psi
- Electrical connection: PT4-M60
- Approvals: CE marking according to PED, not allowed (SEP)
CE marking according to EMC, CE marked
- Medium compatibility: HFC, HCFC, CFC (not suitable for ammonia and flammable refrigerants!)
- Vibration at 10 – 2000 Hz: Max. 4 g
- Materials: Stainless steel housing, pressure connector and diaphragm in contact with sensed medium
- Pressure Range: PT5 - 07M 12 - 102 psi
PT5 - 18M 0 - 261 psi
PT5 - 30M 0 - 435 psi

Ordering Information

Description	Type	Refrigerant	Pressure Range	Reference #	PCN
Pressure Transmitter	PT5-07M	R22, R134A, R507, R404A, R407C, R124	22" Hg - 100 psi	802350	097748
Pressure Transmitter	PT5-18M	R410	0-261psi	802351	097749
Pressure Transmitter	PT5-30M	R744	0-435psi	802334	097753
Plug/Cable Assemblies	PT4-M60			804805	097717

Standard Product Offering

XEV Kit

The Emerson XEV kit includes a combination of commonly needed components for field installation of an energy efficient, electronic expansion valve solution. The kit includes the Emerson EX series valve, XEV controller, pressure transducer, temperature sensor, transformer, and all associated cables, all in one box.

Features

- Applicable to multiple refrigerants, including R-404A, R-507, R-407A, R-22, R-134a, R-410A and subcritical CO₂
- Several kit offerings for a wide range of valve capacities
- Specific kit instructions included for faster installation
- XEV-EX48 controller is pre-programmed for use with the included components, allowing for easy setup
- An RS485 serial link allows the XEV-EX48 controller to connect (via Modbus®) to monitoring systems, including Emerson's E2 system controller
- Controller kit also available that includes all control components without the EXV solution



Ordering Information

PCN	Description	Includes
Individual Controller		<ul style="list-style-type: none"> • XEV EX48 controller* • XEV electrical connectors
900001	XEV EX48	
Complete Kits		<ul style="list-style-type: none"> • XEV EX48 controller* • XEV electrical connectors • EX valve (4,5,6,7,8) • EXV-M60 valve cable • PT5-18M pressure transducer • PT4-M60 transducer cable • ECN-N60 temperature sensor • 90-T40F3 24V transformer, 40VA 60HZ 120/208/240V
900004	XEV EX4 KIT	
900005	XEV EX5 KIT	
900006	XEV EX6 KIT	
900007	XEV EX7 KIT	
900008	XEV EX8 KIT	
Complete Kit Less Valve		Complete kit components listed above, without a valve
900003	XEV Kit Less Valve	
Refrigerants		
R-404A, R-507, R-407A, R-22, R-134a, R-410A, CO ₂ subcritical		

*The XEV-EX48 superheat controller comes pre-set to specifically work with all other Emerson components listed above.

Quick Select Guide – Refrigeration Applications

Application	Feature	Valve	Nominal Liquid Capacity R-22 (in tons)*	Nominal Liquid Capacity R-410A (in tons)*
		100RB2	1.3	
		200RB2	3.6	
		200RB3	4.8	
		200RB4	8.0	
		200RB5	8.2	
		200RB6	9.5	
		200RB7	17.0	
		200RB9	30.5	
		200RB12	34.9	
		200RD 2		3.4
		200RD 3		4.5
		200RD 4		7.5
		200RD 5		7.7
		200RD 6		8.9
		240RA8	15.6	
		240RA9 (5/8)	23.3	
		240RA9 (1-1/8)	30.5	
		240RA12	34.9	
	240RA16	58.0		
	240RA20	95.4		
	Two Way, Normally Open Solenoid Valve	500RB2	3.1	
		500RB3	4.8	
		500RB4	5.6	
		500RB5	8.2	
		500RB6	10.0	
		500RB7	15.6	
540RA8		15.6		
540RA9 (5/8)		23.3		
540RA9 (1-1/8)		30.5		
540RA12		34.9		
540RA16	58.0			
540RA20	95.4			

* 3 psi pressure drop per ARI Standard 760.
All ratings are based on largest connection size.

100RB

The 100RB is a direct-acting, 2-way, normally closed valve. 100 RB valves are used for liquid or discharge gas refrigerant service.

Features

- One coil fits all valve sizes
- Extended ends for easy installation (standard)
- Long-life molded coils
- PTFE O-ring for superior external sealing



Options

- SAE or ODF connection sizes in 1/4" and 3/8", 1/4" NPTF

Specifications

- Maximum fluid temperature: 250°F
- Maximum working pressure: 500 psig
- MOPD: 300 psig
- UL/CUL file number: MP 604

NOTE: Mounting enclosing tube more than 90° off vertical up position is not recommended.

Nomenclature example: 100RB 2F2 VLC

100R	B	2	F	2	VLC
Valve Series	Design Series	Port Size (in 1/16")	Connection Type F = SAE S = ODF P = NPTF	Connection Size (in 1/8")	Coil*

*NOTE: Valves are shipped without the solenoid coils (VLC = Valve Less Coil). See coil assemblies for availability.

Ordering Information and Nominal* Liquid Capacity Table – Tons (kW)

PCN	Product Description	Connection Size	R-12	R-134a	R-22	R-407C	R-404A/R-507	R-502
047503	100RB 2S2 VLC	1/4" ODF	1.0 (3.5)	1.2 (4.2)	1.27 (4.5)	1.21 (4.3)	.85 (3.0)	.83 (2.9)
047504	100RB 2S3 VLC	3/8" ODF						
047505	100RB 2S4 VLC	1/2" ODF						
047500	100RB 2F2 VLC	1/4" SAE						
047501	100RB 2F3 VLC	3/8" SAE						
047502	100RB 2P2 VLC	1/4" NPTF						

Capacities based on 100°F liquid and 40°F saturated evaporator per ARI standard 760-87.

*See Extended Capacity Tables for ratings at a wide range of conditions.

Standard Product Offering

100RB

Dimensional Data (in)

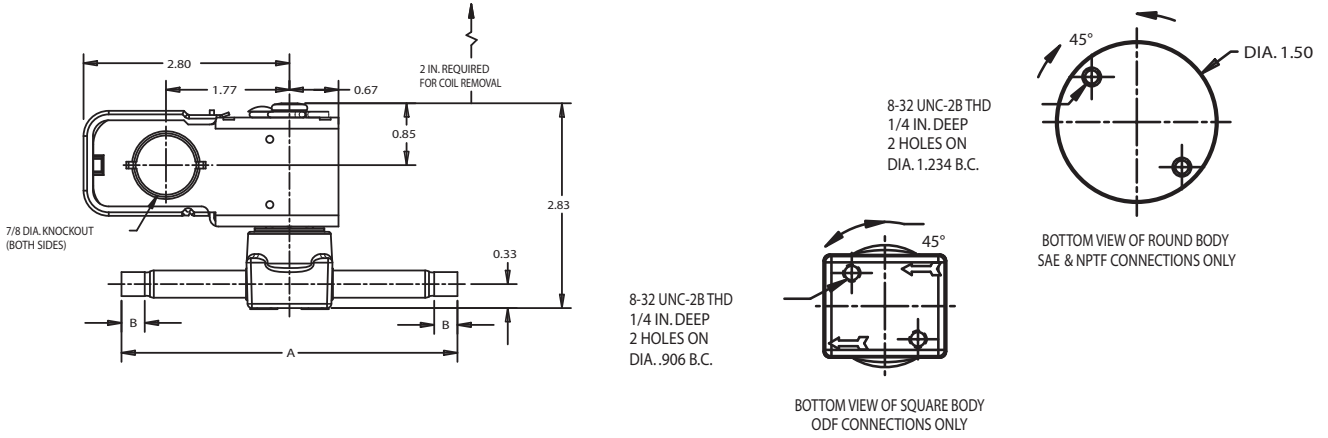

VALVE	CONNECTION SIZE	A	B
100RB 2S2 VLC	1/4 ODF	4.63	0.31
100RB 2S3 VLC	3/8 ODF	4.63	0.31
100RB 2S4 VLC	1/2 ODF	4.63	0.38
100RB 2F2 VLC	1/4 SAE	3.10	-
100RB 2F3 VLC	3/8 SAE	3.47	-
100RB 2P2 VLC	1/4 NPTF	1.56	-

Exploded View & Parts Kit Data

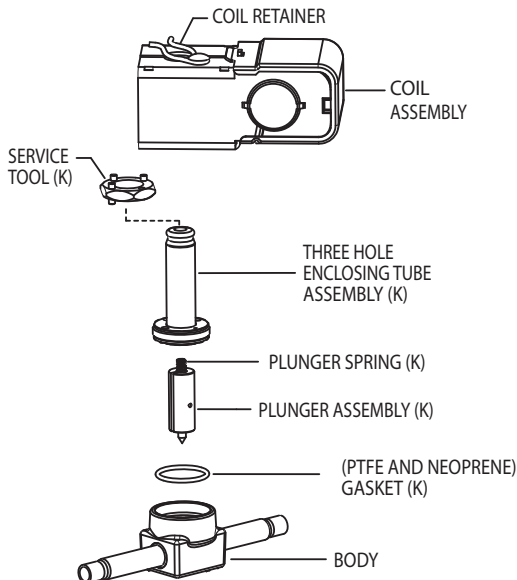

Valve Repair Kit

K indicates part is supplied in valve repair kit KS30112 (PCN 049191)
Note: Universal (2/3 hole) spanner wrench X11981-1 (PCN 027451) included in complete repair kit.

Coil Assembly

See coil assemblies for availability.

Parts Kit

KG-10041 PCN: 054812
(Contains 12 pieces each of PTFE and neoprene O-rings.)

200RB

The 200RB is a pilot-operated, 2-way, normally closed valve. 200RB valves are used for liquid, discharge, or suction gas refrigerant service.

Features

- One coil fits all valve sizes
- Extended ends for easy installation (standard)
- Long-life molded coils
- PTFE O-ring for superior external sealing

Options

- Available in 7 orifice sizes
- Manual stem or mounting stud
- Bi-Flow operation-conversion either factory assembled or with kit (except 200RB 7 & 9)



Specifications

- Maximum fluid temperature: 250°F
- Maximum working pressure: 500 psig
- Minimum operating pressure drop: 2 psi
- MOPD: 300 psig
- UL/CUL file number: MP604

NOTE: Mounting enclosing tube more than 90° off vertical up position is not recommended.

Nomenclature example: 200RB 4T3M VLC

200R	B	4	T	3	M	VLC
Valve Series	Design Series	Port Size (in 1/16")	Connection Type F = SAE S = ODF P = NPTF T = Copper Extended Ends	Connection Size (in 1/8")	M = manual stem T = mounting stud (optional)	Coil*

*NOTE: Valves are shipped without the solenoid coils (VLC = Valve Less Coil). See coil assemblies for availability.

Ordering Information and Nominal* Liquid Capacity Table – Tons (kW)

Standard Valve	PCN		Description	Connection Size	R-12	R-134a	R-22	R-407C	R-404A/R-507	R-502
	Mounting Stud ¹	Manual Stem ²								
053104	--	N/A	200RB 2 F 2	1/4 SAE	2.3 (8.1)	2.7 (9.5)	3.6 (12.7)	3.4 (12.0)	1.9 (6.7)	1.9 (6.7)
062611	--	N/A	200RB 2 F 3	3/8 SAE						
053105	053236	N/A	200RB 2 T 2	1/4 ODF						
053106	054170	N/A	200RB 2 T 3	3/8 ODF						
052725	--	--	200RB 3 F 2	1/4 SAE	3.0 (10.6)	3.6 (12.7)	4.8 (16.9)	4.5 (15.8)	2.5 (8.8)	2.6 (9.1)
052726	056438	--	200RB 3 F 3	3/8 SAE						
052727	055855	--	200RB 3 F 4	1/2 SAE						
049608	--	--	200RB 3 T 2	1/4 ODF						
049609	049585	065620	200RB 3 T 3	3/8 ODF						
049692	--	065621	200RB 3 T 4	1/2 ODF						
047506	047508	047507	200RB 4 F 3	3/8 SAE	5.0 (17.6)	6.0 (21.1)	8.0 (28.1)	7.5 (26.4)	4.2 (14.8)	4.2 (14.8)
059728	047510	047509	200RB 4 P 3	3/8 NPTF						
047511	047513	047512	200RB 4 S 3	3/8 ODF X 1/2 ODM						
047516	047515	047514	200RB 4 S 4	1/2 ODF X 5/8 ODM						
047517	049162	049186	200RB 4 T 3	3/8 ODF						
047518	049163	049187	200RB 4 T 4	1/2 ODF						
058950	058045	056518	200RB 4 T 5	5/8 ODF						
047519	047521	047520	200RB 5 F 4	1/2 SAE	5.2 (18.3)	6.2 (21.8)	8.2 (28.8)	7.7 (27.1)	4.3 (15.1)	4.5 (15.8)
059729	047523	047522	200RB 5 F 5	5/8 SAE						
047524	047526	047525	200RB 5 S 4	1/2 ODF X 5/8 ODM						
049201	047528	047527	200RB 5 S 5	5/8 ODF						
061227	054323	--	200RB 5 T 3	3/8 ODF						
057206	049164	049188	200RB 5 T 4	1/2 ODF						
059730	049165	049189	200RB 5 T 5	5/8 ODF						
059731	047531	047530	200RB 6 F 4	1/2 SAE	6.0 (21.1)	7.2 (25.3)	9.5 (33.4)	8.9 (31.3)	5.0 (17.6)	5.1 (17.9)
059732	047534	047533	200RB 6 F 5	5/8 SAE						
059733	047536	047535	200RB 6 P 3	3/8 NPTF						
047537	047539	047538	200RB 6 S 4	1/2 ODF X 5/8 ODM						
047540	047542	047541	200RB 6 S 5	5/8 ODF						
047544	047546	047545	200RB 6 T 4	1/2 ODF						
056766	047548	047547	200RB 6 T 5	5/8 ODF						
064037	--	--	200RB 7 S 5	5/8 ODF X 7/8 ODM	10.8 (38.0)	12.7 (44.7)	17.0 (59.8)	16.2 (57.0)	9.1 (32.0)	9.2 (32.4)
064062	--	--	200RB 7 T 4	1/2 ODF						
064063	064562	064267	200RB 7 T 5	5/8 ODF						
064282	064284	064283	200RB 7 T 7	7/8 ODF						
064762	064764	064763	200RB 9 T 5	5/8 ODF	19.6 (68.9)	23.6 (83.0)	30.5 (107.3)	29.0 (102.0)	16.4 (57.7)	16.2 (57.0)
064645	064766	064765	200RB 9 T 7	7/8 ODF						
064767	064769	064768	200RB 9 T 9	1 1/8 ODF						

¹ Add "T" to the end of description for Mounting Stud

² Add "M" to the end of the description for Manual Stem

Capacities based on 100°F liquid and 40°F saturated evaporator per ARI standard 760-87.

All ratings are based on largest connection size.

*See Extended Capacity Tables for ratings at a wide range of conditions.

Standard Product Offering

200RB

Ordering Information and Nominal Liquid Capacity Table for Bi-Flow Solenoids - Tons (kW)

PCN			Description	Connection Size	R-12	R-134a	R-22	R-407C	R-404A/R-507	R-502
Standard Valve	Mounting Stud	Manual Stem								
009689	--	--	200RB GS-1925 3 T 3	3/8 ODF	3.7 (13.0)	4.4 (15.6)	4.8 (17.0)	4.5 (16.0)	3.2 (11.3)	3.1 (11.0)
009690	--	--	200RB GS-1926 4 T 3	3/8 ODF	4.4 (15.6)	5.3 (18.6)	5.6 (19.8)	5.3 (18.8)	3.7 (13.1)	3.6 (12.7)
009692	--	--	200RB GS-1928 5 T 4	1/2 ODF	6.5 (23.0)	7.8 (27.7)	8.2 (29.0)	7.8 (27.6)	54. (19.1)	5.3 (18.8)
009693	--	--	200RB GS-1929 5 T 5	5/8 ODF						
009694	--	--	200RB GS-1930 6 T 5	5/8 ODF	7.8 (27.7)	9.4 (33.4)	10.0 (35.4)	9.5 (33.6)	6.5 (23.0)	6.5 (23.0)

Standard Product Offering

200RB 2-6 Dimensional Data (in)

Without Extended Ends

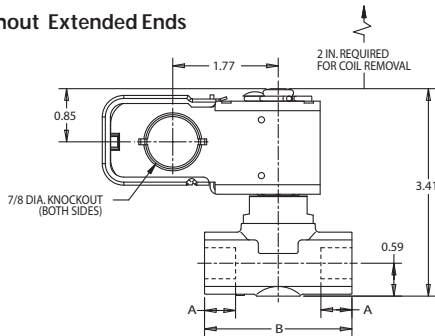

With Extended Ends

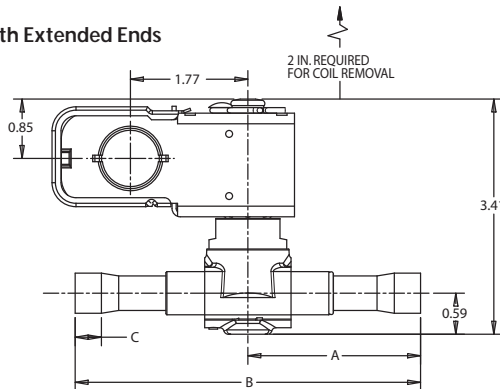

200RB 7 & 9 Dimensional Data (in)

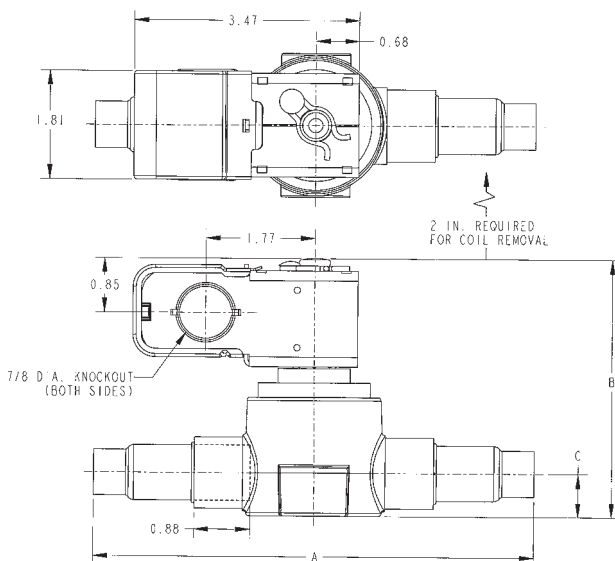

Without Extended Ends

Valve	Port Size	Conn. Size & Style	A	B
200RB 4P2	1/4	1/4 NPTF	-	2.37
200RB 4P3		3/8 NPTF	-	
200RB 4S3		3/8 ODF x 1/2 ODM	0.50	
200RB 4S4		1/2 ODF x 5/8 ODM	0.56	
200RB 4F3		3/8 SAE (male flare)	-	
200RB 5P3	5/16	3/8 NPTF	-	2.37
200RB 5S4		1/2 ODF x 5/8 ODM	0.56	
200RB 5S5		5/8 ODF	-	
200RB 5F4		1/2 SAE (male flare)	-	
200RB 5F5		5/8 SAE (male flare)	-	
200RB 6P3	3/8	3/8 NPTF	-	2.37
200RB 6S4		1/2 ODF x 5/8 ODM	0.56	
200RB 6S5		5/8 ODF	-	
200RB 6F4		1/2 SAE (male flare)	-	
200RB 6F5		5/8 SAE (male flare)	-	

With Extended Ends

Valve	Port Size	Conn. Size & Style	A	B	C
200RB 2T2	1/8	1/4 ODF	2.42	4.62	0.25
200RB 2T3		3/8 ODF			0.31
200RB 3T2	3/16	1/4 ODF	2.50	5.00	0.25
200RB 3T3		3/8 ODF			0.31
200RB 3T4	1/4	1/2 ODF	2.31	4.62	0.38
200RB 4T4		5/8 ODF			0.50
200RB 4T5	5/16	3/8 ODF	2.50	6.50	0.31
200RB 5T3		1/2 ODF			0.38
200RB 5T4	3/8	5/8 ODF	2.31	4.62	0.31
200RB 5T5		5/8 ODF			0.50
200RB 6T3	5/8	3/8 ODF	2.50	5.00	0.31
200RB 6T4		1/2 ODF			0.38
200RB 6T5		5/8 ODF			0.50

Valve	Port Size	Conn. Size & Style	A	B	C
200RB7S5	7/16	5/8 ODF x 7/8 ODM	2.98	3.69	0.53
200RB7T5		5/8 ODF x 5/8 ODF	6.88		
200RB7T7		7/8 ODF x 7/8 ODF	7.13		
200RB9T5	9/16	5/8 ODF x 5/8 ODF	6.88	4.05	0.68
200RB9T6		3/4 ODF x 3/4 ODF	7.38		
200RB9T7		7/8 ODF x 7/8 ODF	7.13		
200RB9T9		1 1/8 ODF x 1 1/8 ODF	8.50		

200RB Valve Kits

Exploded View & Parts Kit Data

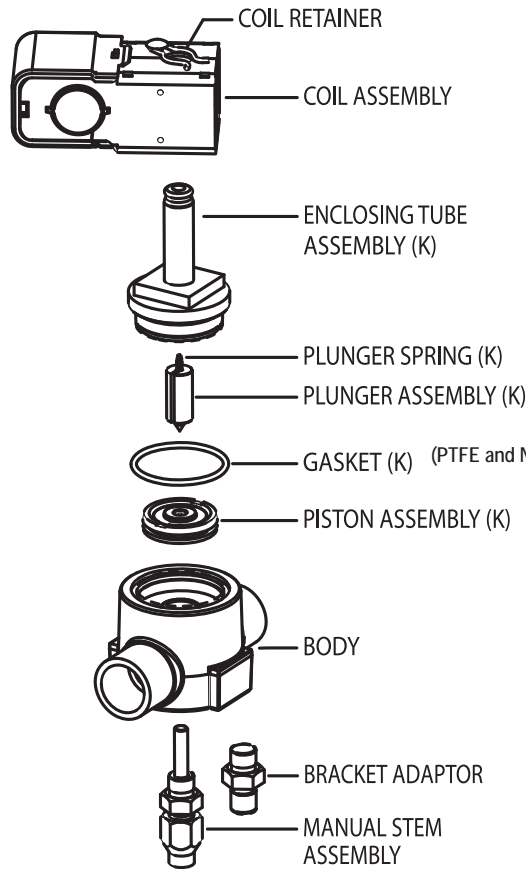

Replace with same gasket color and material; discard other

Valve Repair Kit
 K indicates part is supplied in valve repair kit KS30386. (PCN 066223)

Gasket Kit
 Gasket Kit KG10025 (PCN 049190) (contains 12 pieces - each of PTFE and neoprene O-rings)

Coil Assembly
 See coil assemblies for availability.

Valve Kits

Valve	Complete Kit	PCN	Manual Opening Kit	PCN	Bi-Flow Kit	PCN	Gasket Kit	PCN
200RB2	KS30386	066223	N/A	N/A	KS30387	066224	KG10025	049190
200RB3	KS30386	066223	KS30377	065695	KS30387	066224	KG10025	049190
200RB4	KS30386	066223	KS30117	053959	KS30387	066224	KG10025	049190
200RB5	KS30386	066223	KS30117	053959	KS30387	066224	KG10025	049190
200RB6	KS30386	066223	KS30117	053959	KS30387	066224	KG10025	049190
200RB7	KS30354	064263	KS30361	064831	N/A	N/A	KG00002	064262
200RB9	KS30362	064825	KS30364	064832	N/A	N/A	KG00003	064830

Standard Product Offering

200RB Bi-Flow Conversion

Standard 200RB uni-directional valves can be converted to Bi-Flow operation by replacing the internal parts with the components in kit KS30387 (PCN 066224). Unlike the standard valve which permits flow in one direction only when energized, the Bi-Flow version allows the valve to flow in either direction, depending on differential pressures, when energized. If the valve is not energized when flowing in the reverse direction, valve "flutter" will occur. Also, with the valve de-energized, a higher downstream pressure than upstream (back-flow) will force the valve open.

NOTE: A 200RB7 and 200RB9 and cannot be converted to a Bi-Flow valve.

200RD

The 200RD is a pilot-operated, 2-way, normally closed solenoid valve that is suitable for all refrigerants, including R-410A. 200RD valves are used for liquid, discharge, or suction gas refrigerant service.

R-410A



Features

- One coil fits all valve sizes
- Extended ends for easy installation (standard)
- Long-life molded coils
- PTFE O-ring for superior external sealing

Options

- Available in 7 orifice sizes
- Manual stem or mounting stud
- Bi-Flow operation-conversion either factory assembled or with kit except 200RD 7 and 200RD 9

Specifications

- Maximum fluid temperature: 250°F
- Maximum working pressure: 680 psig
- Minimum operating pressure drop: 2 psi
- MOPD: 550 psig
- UL/CUL file number: MP604

NOTE: Mounting enclosing tube more than 90° off vertical up position is not recommended.

Nomenclature

example: 200RD 4T3M VLC

200R	D	4	T	3	M	VLC
Valve Series	Design Series	Port Size (in 1/16")	Connection Type T = Copper Extended Ends	Connection Size (In 1/8")	M = manual stem T = mounting stud (optional)	Coil*

*NOTE: Valves are shipped without the solenoid coils (VLC = Valve Less Coil). See available coil assemblies.

Ordering Information and Nominal * Liquid Capacity - Tons (kW)

PCN			Description	Connection Size	R-410A	R-744
Standard Valve	Mounting Stud ¹	Manual Stem ²				
066158	066179	-	200RD 2 T 2	1/4 ODF	3.4 (11.9)	8.16 (28.7)
066159	066180	-	200RD 2 T 3	3/8 ODF		
066160	-	-	200RD 3 T 2	1/4 ODF	4.5 (15.8)	10.86 (38.2)
066161	066182	066203	200RD 3 T 3	3/8 ODF		
066162	066183	066204	200RD 3 T 4	1/2 ODF		
066163	066184	066205	200RD 4 T 3	3/8 ODF	7.5 (26.4)	18.01 (63.3)
066164	066185	066206	200RD 4 T 4	1/2 ODF		
066165	066186	066181	200RD 4 T 5	5/8 ODF	7.7 (27.1)	18.62 (65.5)
066166	066187	066208	200RD 5 T 3	3/8 ODF		
066167	066188	066209	200RD 5 T 4	1/2 ODF		
066168	066189	066210	200RD 5 T 5	5/8 ODF	8.9 (31.3)	21.49 (75.6)
066169	066190	066211	200RD 6 T 4	1/2 ODF		
066170	066191	066212	200RD 6 T 5	5/8 ODF	15.7 (55.22)	37.62 (132.3)
066172	066195	066214	200RD 7 T 5	5/8 ODF		
066173	066194	066215	200RD 7 T 7	7/8 ODF		
066174	066202	066216	200RD 9 T 5	5/8 ODF	27.7 (97.59)	67.66 (238.0)
066175	066196	066217	200RD 9 T 7	7/8 ODF		
066176	066197	066218	200RD 9 T 9	1 1/8 ODF		

¹ Add "T" to the end of description for Mounting Stud
² Add "M" to the end of the description for Manual Stem

Capacities based on ARI standard.
 All ratings are based on largest connection size
 *See Extended Capacity Tables for ratings at a wide range of conditions.

Standard Product Offering

200RD

Ordering Information and Nominal Liquid Capacity Table for Bi-Flow Solenoids - Tons (kW)

PCN			Description	Connection Size	R-12	R-134a	R-22	R-407C	R-404A/R-507	R-502	R-410A
Standard Valve	Mounting Stud	Manual Stem									
016996	--	--	200RD3T3 VLC BF	3/8 ODF	3.04 (10.69)	3.62 (12.73)	4.80 (16.88)	4.51 (15.86)	2.52 (8.86)	3.14 (11.04)	4.50 (15.83)
016997	--	--	200RD4T3 VLC BF	3/8 ODF	4.95 (17.41)	6.00 (21.10)	7.95 (27.96)	7.48 (26.31)	4.18 (14.70)	5.21 (18.32)	7.45 (26.20)
016998	--	--	200RD5T4 VLC BF	1/2 ODF	5.20 (18.29)	6.21 (21.84)	8.22 (28.91)	7.73 (27.19)	4.33 (15.23)	5.39 (18.96)	7.71 (27.11)
016999	--	--	200RD5T5 VLC BF	5/8 ODF							
017000	--	--	200RD6T5 VLC BF	5/8 ODF	6.01 (21.14)	7.16 (25.18)	9.48 (33.34)	8.92 (31.37)	4.99 (17.55)	6.22 (21.87)	8.89 (31.26)

With Extended Ends

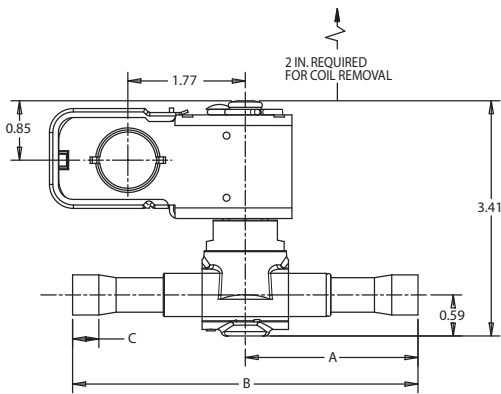

With Extended Ends

Valve	Port Size	Conn. Size & Style	A	B	C
200RD 2T2	1/8	1/4 ODF	2.42	4.62	0.25
200RD 2T3		3/8 ODF			0.31
200RD 3T2	1/4 ODF	0.25			
200RD 3T3	3/8 ODF	0.31			
200RD 3T4	1/4	1/2 ODF	2.50	5.00	0.38
200RD 4T4		5/8 ODF	3.25	6.50	0.50
200RD 4T5	5/16	3/8 ODF	2.31	4.62	0.31
200RD 5T3		1/2 ODF	2.50	5.00	0.38
200RD 5T4		5/8 ODF	3.25	6.50	0.50
200RD 5T5	3/8	1/2 ODF	2.50	5.00	0.38
200RD 6T4		5/8 ODF	3.25	6.50	0.50
200RD 6T5					

200RD7 & 9 Dimensional Data (in)

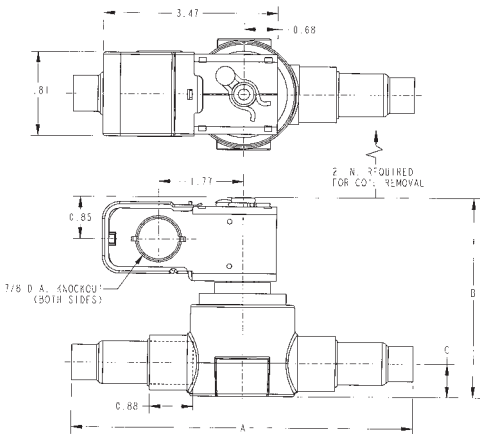

Valve	Port Size	Conn. Size & Style	A	B	C
200RD7S5	7/16	5/8 ODF x 7/8 ODM	2.98	3.69	0.53
200RD7T5		5/8 ODF x 5/8 ODF	6.88		
200RD7T7		7/8 ODF x 7/8 ODF	7.13		
200RD9T5	9/16	5/8 ODF x 5/8 ODF	6.88	4.05	0.68
200RD9T6		3/4 ODF x 3/4 ODF	7.38		
200RD9T7		7/8 ODF x 7/8 ODF	7.13		
200RD9T9		1 1/8 ODF x 1 1/8 ODF	8.50		

Exploded View & Parts Kit Data

Valve Repair Kit
K indicates part is supplied in valve repair kit **KS30386**. (PCN 066223)

Gasket Kit
Gasket Kit **KG10025** (PCN 049190)
(contains 12 pieces - each of PTFE and neoprene O-rings)

Coil Assembly
See coil assemblies for availability.

Bi-Flow Conversion Kit
KS30387 (PCN 066224)

(Not available for 200RD 7 and 9)

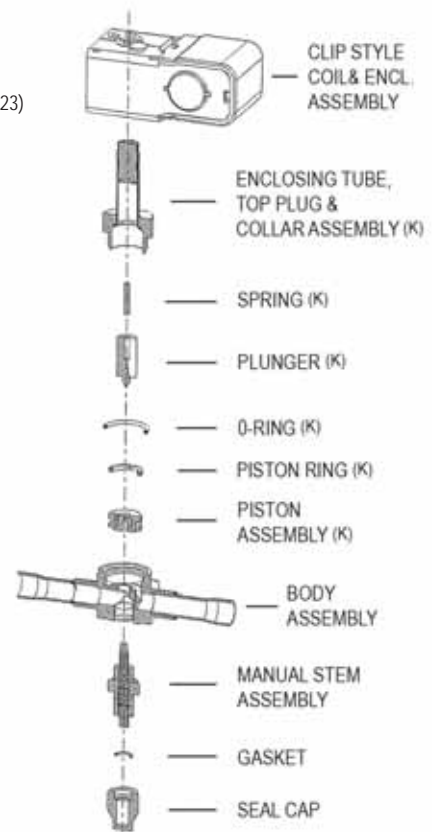

240RA

The 240RA is a 2-way, normally closed diaphragm valve. 240RA valves are used for liquid, suction, and hot gas service.

Features

- One coil fits all valve sizes
- Can be brazed into the line without disassembly
- PTFE diaphragm for high temperature applications
- Extended ends for easy installation (standard)
- Long-life molded coils
- Mounting stud models can be field converted to manual stem

Options

- Manual stem or mounting stud



Specifications

- Maximum fluid temperature: 250°F
- Maximum working pressure: 500 psig
- MOPD: 300 psig
- UL/CUL file number: MP604

NOTE: Mounting enclosing tube more than 90° off vertical up position is not recommended.

Nomenclature example: 240RA 8T5M VLC

240R	A**	8	T	5	M	VLC
Valve Series	Design Series	Port Size (in 1/16")	Connection Type T = copper extended ends	Connection Size (in 1/8")	M = manual stem T = mounting stud (optional)	Coil*

* NOTE: Valves are shipped without the solenoid coils (VLC = Valve Less Coil). See coil assemblies for availability.

**NOTE: Letter "H" is no longer used since all 240RA valves now contain the high temperature diaphragm for hot gas.

Ordering Information and Nominal* Liquid Capacity Table – Tons (kW)

PCN			Description	Connection Size	R-12	R-134a	R-22	R-407C	R-404A/R-507	R-502
Standard Valve	Mounting Stud ¹	Manual Stem ²								
060374	040846	040845	240RA 8 T 5	5/8 ODF	12.2 (43.4)	14.8 (52.5)	15.6 (55.2)	14.8 (52.4)	8.4 (29.5)	10.1 (35.0)
060375	044860	045753	240RA 8 T 7	7/8 ODF						
060376	040848	040847	240RA 9 T 5	5/8 ODF	18.2 (64.6)	22.0 (78.0)	23.3 (82.5)	22.1 (78.2)	15.3 (54.2)	15.1 (53.5)
060377	043205	043204	240RA 9 T 7	7/8 ODF	24.0 (85.0)	28.9 (102.3)	30.5 (108.0)	29.0 (103.0)	21.0 (71.1)	19.8 (70.1)
060378	044861	045752	240RA 9 T 9	1 1/8 ODF						
060379	040850	040849	240RA 12 T 7	7/8 ODF	27.6 (97.6)	33.2 (117.5)	34.9 (124.0)	33.2 (118.0)	23.0 (81.4)	22.7 (80.4)
060380	043959	045549	240RA 12 T 9	1 1/8 ODF						
060381	042549	042548	240RA 16 T 9	1 1/8 ODF	37.3 (132.0)	55.1 (195.1)	58.0 (205.0)	55.2 (195.0)	38.3 (135.0)	37.3 (133.0)
060382	044428	044788	240RA 16 T 11	1 3/8 ODF						
060383	047761	046636	240RA 20 T 11	1 3/8 ODF	58.8 (208.0)	86.8 (307.4)	95.4 (338.0)	90.8 (321.0)	65.7 (230.0)	62.0 (219.0)
060384	047747	046637	240RA 20 T 13	1 5/8 ODF						
060385	054297	046638	240RA 20 T 17	2 1/8 ODF						

¹ Add "T" to the end of description for Mounting Stud

² Add "M" to the end of the description for Manual Stem

Capacities based on 100°F liquid and 40°F saturated evaporator per ARI standard 760-87.

*See Extended Capacity Tables for ratings at a wide range of conditions.

Standard Product Offering

240RA

Dimensional Data (in)

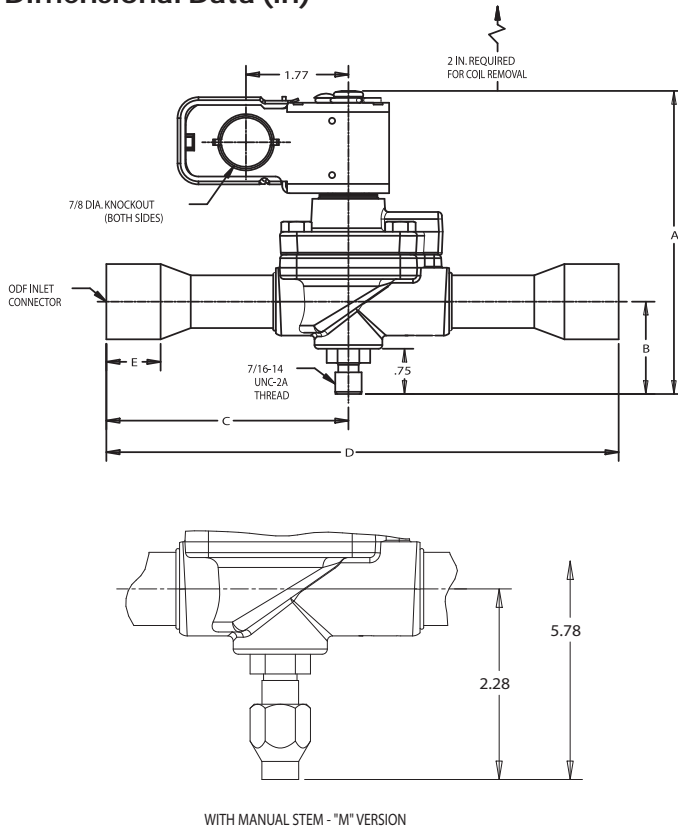

Valve	Port Size	Conn. Size	A	B	C	D	E
240RA8T5T	1/2	5/8 ODF	4.80	1.34	3.28	6.88	0.50
240RA8T5M			5.28	1.83			
240RA8T7T		7/8 ODF	4.80	1.34			
240RA8T7M	5.28		1.83				
240RA9T5T	9/16	5/8 ODF	5.08	1.50	3.20	6.88	0.50
240RA9T5M			5.56	2.08			
240RA9T7T		7/8 ODF	5.08	1.50			
240RA9T7M	5.56		2.08				
240RA9T9T	1-1/8	5/8 ODF	5.08	1.50	4.02	8.50	0.91
240RA9T9M			5.56	2.08			
240RA12T7T		3/4	7/8 ODF	5.08			
240RA12T7M	5.56			2.08			
240RA12T9T	1-1/8		ODF	5.08	1.50	4.02	8.50
240RA12T9M		5.56		2.08			
240RA16T9T	1	1-1/8	5.34	1.66	4.13	9.06	0.91
240RA16T9M			5.80	2.23			
240RA16T11T		1-3/8	ODF	5.34			
240RA16T11M	5.80			2.23			
240RA20T11T	1-1/4	1-3/8	5.45	1.31	5.11	10.81	0.97
240RA20T11M			6.47	2.33			
240RA20T13T		1-5/8	ODF	5.45			
240RA20T13M	6.47			2.33			
240RA20T17T	2-1/8	ODF	5.45	1.31	6.58	13.75	1.34
240RA20T17M			6.47	2.33			

Exploded View & Parts Kit Data

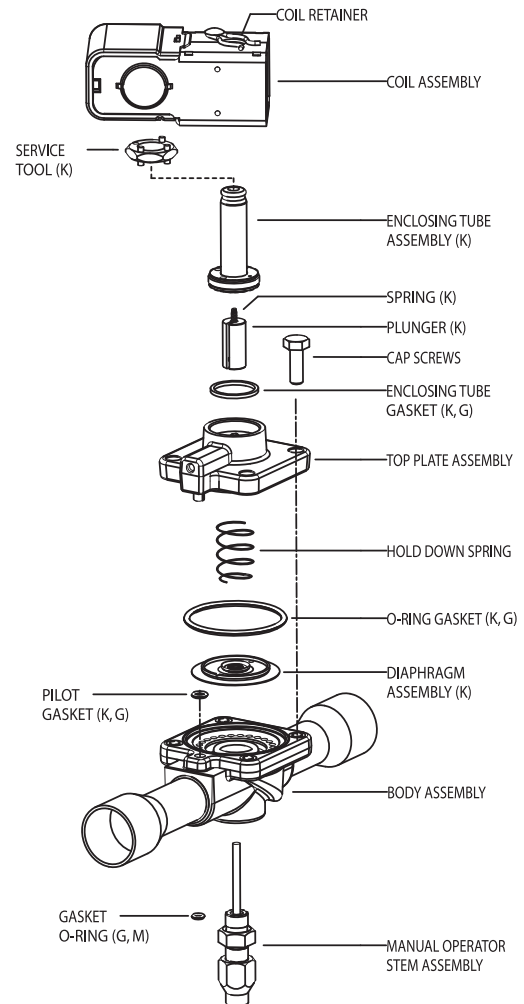

Valve Kits

Valve	Complete Kit	PCN	Manual Opener Kit	PCN
240RA8	KS30321	060626	KS30066	044657
240RA9	KS30322	060627	KS30067	044658
240RA12	KS30323	060628	KS30067	044658
240RA16	KS30324	060629	KS30068	044491
240RA20	KS30325	060630	KS30098	047723

Gasket Kit for all 240RA valves is KG10028 (PCN 054356)

Standard Product Offering

Valve Repair Kit

K indicates part is supplied in complete valve repair kit.

Manual Stem Kit

M indicates part is supplied in manual stem kit.

Gasket Kit

G indicates gasket is supplied in gasket kit.
Note: Spanner wrench (X11981-1 service tool) included in complete valve kit.

Coil Assembly

See coil assemblies for availability.

500RB

The 500RB is a pilot-operated, 2-way, normally open valve. 500RB valves are used for liquid, suction or discharge gas refrigerant service.

Features

- One coil fits all valve sizes
- Extended ends for easy installation
- Can be positioned in remote locations
- Long-life molded coils
- Low pressure differential required for full opening
- PTFE O-ring for superior external sealing

Options

- Connection types: SAE, ODF, NPTF and ODF inlet with ODM outlet



Specifications

- Maximum fluid temperature: 250°F
- Maximum working pressure: 500 psig
- MOPD: 275 psig
- UL/CUL file number: MP604

NOTE: Mounting enclosing tube more than 90° off vertical up position is not recommended.

NOTE: This valve requires a DM, MM or ASC2-Type coil assembly. ASC2-Type Coil requires cable assembly (PCN:059261).

Nomenclature example: 500RB 4T3 VLC

500R	B	4	T	3	VLC
Valve Series	Design Series	Port Size (in 1/16")	Connection Type F = SAE T = ODF (copper extended fittings) P = NPTF S = ODF inlet/ODM outlet	Connection Size (in 1/8")	Coil*

* NOTE: Valves are shipped without the solenoid coils (VLC = Valve Less Coil). See coil assemblies for availability.

Ordering Information and Nominal* Liquid Capacity Table – Tons (kW)								
PCN	Description	Connection Size	R-12	R-134a	R-22	R-407C	R-404A/R-507	R-502
063274	500RB 2 F 2	1/4 SAE	2.4 (8.7)	2.9 (10.4)	3.1 (11.0)	2.9 (10.3)	2.1 (7.4)	2.0 (7.1)
063276	500RB 2 F 3	3/8 SAE						
063278	500RB 2 T 2	1/4 ODF						
063280	500RB 2 T 3	3/8 ODF	3.7 (13.0)	4.4 (15.6)	4.8 (17.0)	4.5 (16.0)	3.2 (11.3)	3.1 (11.0)
063282	500RB 3 F 2	1/4 SAE						
063284	500RB 3 F 3	3/8 SAE						
063286	500RB 3 F 4	1/2 SAE						
063288	500RB 3 T 2	1/4 ODF						
063290	500RB 3 T 3	3/8 ODF						
063292	500RB 3 T 4	1/2 ODF						
063294	500RB 4 F 3	3/8 SAE	4.4 (15.6)	5.3 (18.6)	5.6 (19.8)	5.3 (18.8)	3.7 (13.1)	3.6 (12.7)
063296	500RB 4 P 2	1/4 NPTF						
063298	500RB 4 P 3	3/8 NPTF						
063300	500RB 4 S 3	3/8 ODF x 1/2 ODM						
063302	500RB 4 S 4	1/2 ODF x 5/8 ODM						
063304	500RB 4 T 2	1/4 ODF						
063306	500RB 4 T 3	3/8 ODF						
063308	500RB 4 T 4	1/2 ODF						
063310	500RB 4 T 5	5/8 ODF						
063312	500RB 5 F 4	1/2 SAE						
063314	500RB 5 F 5	5/8 SAE						
063316	500RB 5 P 3	3/8 NPTF						
063318	500RB 5 S 4	1/2 ODF x 5/8 ODM						
063320	500RB 5 S 5	5/8 ODF						
063322	500RB 5 T 3	3/8 ODF						
063323	500RB 5 T 4	1/2 ODF						
063325	500RB 5 T 5	5/8 ODF	7.8 (27.7)	9.4 (33.4)	10.0 (35.4)	9.5 (33.6)	6.5 (23.0)	6.5 (23.0)
063327	500RB 6 F 4	1/2 SAE						
063329	500RB 6 F 5	5/8 SAE						
063331	500RB 6 P 3	3/8 NPTF						
063333	500RB 6 S 4	1/2 ODF x 5/8 ODM						
063335	500RB 6 S 5	5/8 ODF						
063337	500RB 6 T 3	3/8 ODF						
063339	500RB 6 T 4	1/2 ODF						
063341	500RB 6 T 5	5/8 ODF						
064038	500RB 7 S 5	5/8 ODF x 7/8 ODM						
064064	500RB 7 T 4	1/2 ODF						
064065	500RB 7 T 5	5/8 ODF						

Capacities based on 100°F liquid and 40°F saturated evaporator per ARI standard 760-87.

*See Extended Capacity Tables for ratings at a wide range of conditions.

Standard Product Offering

500RB

Dimensional Data (in)

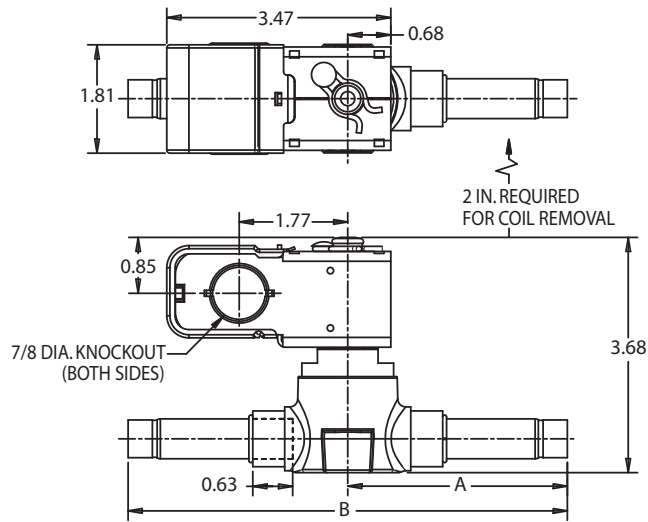

*NOTE: Drawing indicates extended copper tube version.

Exploded View & Parts Kit Data

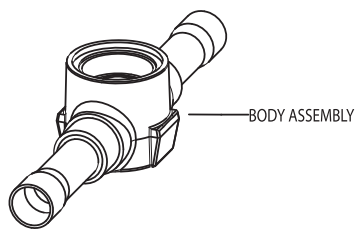
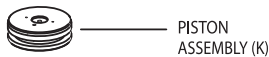
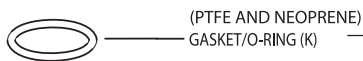
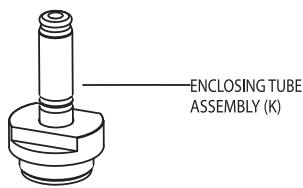
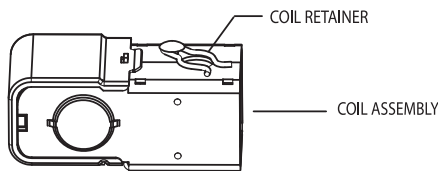

Without Extended Ends

Valve	Port Size	Conn. Size & Style	A	B
500RB 4P2	1/4	1/4 NPTF	0.50	2.37
500RB 4P3		3/8 NPTF		2.37
500RB 4S3		3/8 ODF X 1/2 ODM		2.37
500RB 4S4		1/2 ODF X 5/8 ODM		2.37
500RB 4F3	5/16	3/8 SAE (male flare)	0.56	3.12
500RB 5P3		3/8 NPTF		2.37
500RB 5S4		1/2 ODF X 5/8 ODM		2.37
500RB 5S5	3/8	5/8 ODF	0.56	2.37
500RB 5F4		1/2 SAE (male flare)		3.50
500RB 5F5		5/8 SAE (male flare)		3.75
500RB 6P3	7/16	3/8 NPTF	0.63	2.37
500RB 6S4		1/2 ODF X 5/8 ODM		2.37
500RB 6S5		5/8 ODF		2.37
500RB 6F4		1/2 SAE (male flare)		3.50
500RB 6F5		5/8 SAE (male flare)		3.75
500RB 7S5		5/8 ODF X 7/8 ODM		2.98

With Extended Ends

Valve	Port Size	Conn. Size & Style	A	B
500RB 2T2	1/8	1/4 ODF	2.42	4.67
500RB 2T3		3/8 ODF		
500RB 3T2	3/16	1/4 ODF	2.50	5.00
500RB 3T3		3/8 ODF		
500RB 3T4		1/2 ODF		
500RB 4T4	1/4	1/2 ODF	3.25	6.50
500RB 4T5		5/8 ODF		
500RB 5T3	5/16	3/8 ODF	2.31	4.63
500RB 5T4		1/2 ODF		
500RB 5T5		5/8 ODF		
500RB 6T3	3/8	3/8 ODF	2.50	5.00
500RB 6T4		1/2 ODF		
500RB 6T5		5/8 ODF		
500RB 7T5	7/16	5/8 ODF X 5/8 ODF	-	6.88

Valve Kits

Valve	Complete Kit	PCN
500RB 2-6	KS-30353	064268
500RB 7	KS-30355	064264

Replace with same gasket color and material; discard other

Gasket Kit

Gasket Kit KG10025 - PCN 049190
(contains 12 pieces - each of PTFE and Neoprene O-rings).

Coil Assembly

DM, MM or ASC-Type style only

Use MagMax style coil for operation on DC voltage.
No other DC coil may be used.

540RA

The 540RA is a 2-way, normally open diaphragm valve. 540RA valves are used for liquid, suction and hot gas service.

Features

- Can be brazed into the line without disassembly
- PTFE diaphragm
- Extended ends for easy installation
- Long-life molded coils
- Low pressure differential required for full opening



Specifications

- Maximum fluid temperature: 250°F
- Maximum working pressure: 500 psig
- MOPD: 250 psig
- UL/CUL file number: MP604

NOTE: Mounting enclosing tube more than 90° off vertical up position is not recommended.

NOTE: This valve requires a DM, MM or ASC2-Type coil assembly. ASC2-Type Coil requires snap cap and cable assembly (PCN:059261).

Nomenclature example: 540RA 8T5 VLC

540R	A	8	T	5	VLC
Valve Series	Design Series	Port Size (in 1/16")	Connection Type T = copper entended ends	Connection Size (in 1/8")	Coil*

* NOTE: Valves are shipped without the solenoid coils (VLC = Valve Less Coil). See coil assemblies for availability.

Ordering Information and Nominal* Liquid Capacity Table – Tons (kW)

PCN		Description	Connection Size	R-12	R-134a	R-22	R-407C	R-404A/R-507	R-502
Standard Valve	Mounting Stud ¹								
060391	058573	540RA 8 T 4	1/2 ODF	12.2 (43.4)	14.8 (52.5)	15.6 (55.2)	14.8 (52.4)	10.3 (36.5)	10.1 (35.6)
060392	046265	540RA 8 T 5	5/8 ODF						
060393	046989	540RA 8 T 7	7/8 ODF						
060394	046266	540RA 9 T 5	5/8 ODF	18.2 (64.6)	22.0 (78.0)	23.3 (82.5)	22.1 (78.2)	15.3 (54.2)	15.1 (53.4)
060395	046268	540RA 9 T 7	7/8 ODF	24.0 (85.0)	28.9 (102.3)	30.5 (108.0)	29.0 (103.0)	20.1 (71.1)	19.8 (70.1)
060396	047497	540RA 9 T 9	1 1/8 ODF						
060397	046269	540RA 12 T 7	7/8 ODF	27.6 (97.6)	33.2 (117.5)	34.9 (123.0)	33.2 (118.0)	23.0 (81.0)	22.7 (80.0)
060398	047498	540RA 12 T 9	1 1/8 ODF						
060399	046270	540RA 16 T 9	1 1/8 ODF	37.3 (132.0)	55.1 (195.1)	58.0 (205.0)	55.2 (195.0)	38.3 (136.0)	37.7 (133.0)
060400	047214	540RA 16 T 11	1 3/8 ODF						
060401	047953	540RA 20 T 11	1 3/8 ODF	58.8 (208.0)	86.8 (307.4)	95.4 (338.0)	90.8 (321.0)	65.7 (233.0)	62.0 (219.0)
060402	047954	540RA 20 T 13	1 5/8 ODF						
060403	047955	540RA 20 T 17	2 1/8 ODF						

¹ Add *T* to the end of description for Mounting Stud

Capacities based on 100°F liquid and 40°F saturated evaporator per ARI standard 760-87.

*See Extended Capacity Tables for ratings at a wide range of conditions.

Standard Product Offering

540RA

Thermal Expansion Valves
TXV Extended Capacity Tables
EX Valves and Controls
Solenoid Valves and Coils
Solenoid Capacity Tables
Industrial Solenoid Valves
Shut Off Valves
System Protectors
System Protectors Capacity Tables
Oil Controls
Temperature Pressure Controls

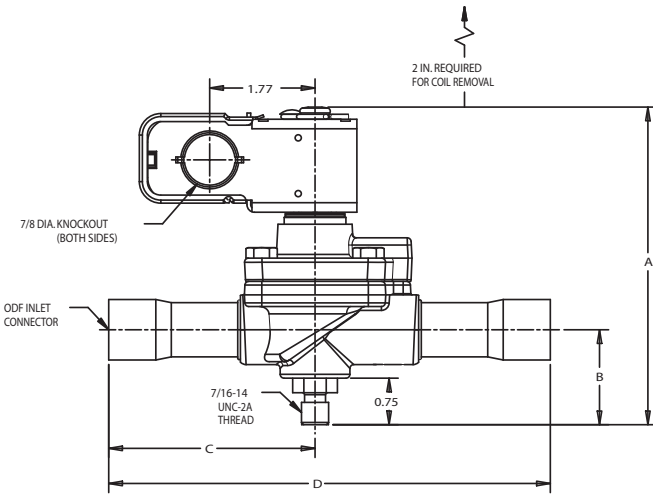

Valve	Port Size	Conn. Size	A	B	C	D
540RA8T5-T	1/2	5/8 ODF	4.80	1.34	3.28	6.88
540RA8T7-T		7/8 ODF			3.41	7.13
540RA9T5-T	9/16	5/8 ODF	5.08	1.50	3.20	6.88
540RA9T7-T		7/8 ODF			3.33	7.13
540RA9T9-T	3/4	1 1/8 ODF	5.08	1.50	4.02	8.50
540RA12T7-T		7/8 ODF			3.52	7.50
540RA12T9-T	1	1 1/8 ODF	5.34	1.66	4.02	8.50
540RA16T9-T		1 1/8 ODF			4.25	9.06
540RA16T11-T	1-1/4	1 3/8 ODF	5.45	1.31	5.25	11.06
540RA20T11-T		1 3/8 ODF			5.11	10.81
540RA20T13-T	1-1/4	1 5/8 ODF	5.45	1.31	5.89	12.38
540RA20T17-T		2 1/8 ODF			6.58	13.75

Exploded View & Parts Kit Data

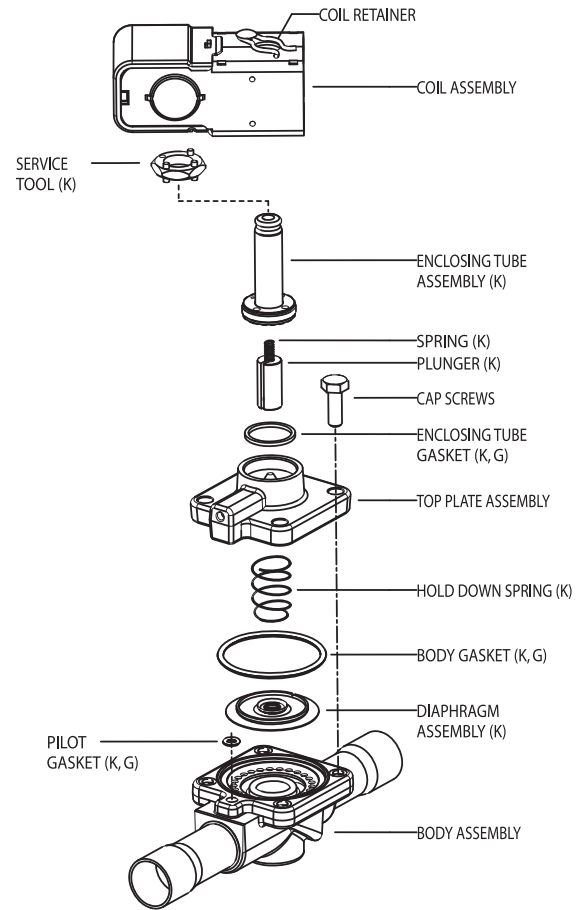

540RA Valve Kits

Valve	Kit #	PCN
540RA8	KS30328	060633
540RA9	KS30329	060634
540RA12	KS30330	060635
540RA16	KS30331	060636
540RA20	KS30332	060637

Gasket Kit for all 540RA valves is KG10028 (PCN 054356)

Standard Product Offering

Valve Repair Kit

K indicates part is supplied in complete valve repair kit.

Gasket Kit

G indicates gasket is supplied in gasket kit.

Note: Spanner wrench X11981-1 (PCN 027451) is included in complete valve kit. (service tool used to remove and replace enclosing tube collar)

Coil Assembly

See coil assemblies for availability.

Coils for Solenoid Valves

Features

- Compact designs
- Coil windings are insulated to provide shock and vibration protection
- ASC2 is designed to provide weather protection
- Interchangeable housings

Voltage Options

- 24V 50/60 Hz
- 120V 50/60 Hz (standard)
- 208-220/208-240V 50/60 Hz
- 480V 50/60 Hz
- 120-240V 50/60 Hz
- 12V D.C. (MM Series recommended)
- 24V D.C. (MM Series recommended)

ASC2 – DIN



Requires ASC2 female connector (PCN 059261).

MMG – Special DC



AMC - 1/2" Conduit



AMG - Junction Box



AMS - Open Frame



Nomenclature

Coil Code		
A	M	G
Series	Insulation	Enclosure
A = 12 Watt B = 15 Watt C = 18 Watt D = 7 Watt M = 4 Watt	B or G = Class B M = Class F H = Class H	C = Conduit Connection F = Open Frame Leads G = Junction Box L = Grommet 18" Leads S = Spade Connection

MAGMAX Coil (Type MM): For Use On DC Applications Only

Voltage	Amperes Holding	Watts Holding
12VDC	0.4	4
24VDC	0.4	4

Solenoid Coil Prefix Selection Table

1) Select Prefix 2) Select Voltage 3) Select PCN

Valve Type	J-Box	Conduit	Leads	Spades	Molded-DIN With Connector
100RB	AMG	AMC	AMF	AMS	ASC2
200RB / 200RD	AMG	AMC	AMF	AMS	ASC2
222CB (Steam)	AHG	AHC	-	-	-
500RB	DMG	-	DMF	DMS	-
540RA	-	-	-	DMS	ASC2
222CB (Water)	AMG	AMC	AMF	AMS	ASC2
Special DC Application	MMG	-	MMF	-	-

* SML is OEM - RMF is Wholesale replacement

Note - All coils NEMA1 except ASC2 NEMA2

AM/EM Coil:

204CD
214CB
211CA
222CB
210CA

Nominal Voltage and Frequency	Applied Voltage and Frequency	204CD		214C		211CA		222CB		210CA	
		Inrush	Holding	Inrush	Holding	Inrush	Holding	Inrush	Holding	Inrush	Holding
24/60	24/60	1.23	0.61	1.17	0.61	0.92	0.61	1.00	0.74	0.92	0.61
120/60	120/60	0.23	0.14	0.22	0.14	0.17	0.14	0.19	0.16	0.17	0.14
240/60	240/60	0.13	0.08	0.12	0.08	0.10	0.08	0.11	0.08	0.10	0.08
480/60	480/60	0.06	0.04	0.05	0.04	0.05	0.04	0.05	0.04	0.05	0.04

See the MM (MAGMAX) Series Coil for DC Applications

Coils for Solenoid Valves

AM Coil: 702RA

Nominal Voltage and Frequency	Applied Voltage and Frequency	Amperes		VA Holding	Watts Max.	Coil Insulation
		Inrush	Holding			
24-50/60	24/50	1.70	1.00	24	17/12	Class F Molded
24-50/60	24/60	1.41	0.64	15		
120-50/60	120/50	0.38	0.24	29		
120-50/60	120/60	0.32	0.16	19		
208-220/50 208-240/60	208/50	0.17	0.10	21		
208-220/50 208-240/60	208/60	0.15	0.06	13		
208-220/50 208-240/60	220/50	0.20	0.14	33		
208-220/50 208-240/60	240/60	0.22	0.09	22		
480-50/60	480/50	0.10	0.07	33		
480-50/60	480/60	0.09	0.04	22		

See the MM (MAGMAX) Series Coil for DC Applications

AM Coil: 100RB 240RA 710/713RA

Nominal Voltage and Frequency	Applied Voltage and Frequency	Amperes		VA Holding	Watts Max.	Coil Insulation
		Inrush	Holding			
24-50/60	24/50	1.20	.96	23	17/12	Class F Molded
24-50/60	24/60	1.0	.74	18		
120-50/60	120/50	.25	.21	25		
120-50/60	120/60	.19	.16	19		
208-220/50 208-240/60	208/50	.14	.08	17		
208-220/50 208-240/60	208/60	.12	.06	12		
208-220/50 208-240/60	220/50	.16	.10	24		
208-220/50 208-240/60	240/60	.13	.08	19		
480-50/60	480/50	.06	.05	24		
480-50/60	480/60	.05	.04	19		

See the MM (MAGMAX) Series Coil for DC Applications

AM Coil: 200RB/200RD

Nominal Voltage and Frequency	Applied Voltage and Frequency	Amperes		VA Holding	Watts Max.	Coil Insulation
		Inrush	Holding			
24-50/60	24/50	2.00	.96	23	17/12	Class F Molded
24-50/60	24/60	1.6	.74	18		
120-50/60	120/50	.45	.21	25		
120-50/60	120/60	.36	.16	19		
208-220/50 208-240/60	208/50	.19	.08	17		
208-220/50 208-240/60	208/60	.15	.06	12		
208-220/50 208-240/60	220/50	.24	.10	24		
208-220/50 208-240/60	240/60	.19	.08	19		
480-50/60	480/50	.11	.05	24		
480-50/60	480/60	.09	.04	19		

See the MM (MAGMAX) Series Coil for DC Applications

Coils for Solenoid Valves

ASC2 Coil: 200RB/200RD 540RA

Nominal Voltage and Frequency	Applied Voltage and Frequency	Amperes		VA Holding	Watts Max.	Coil Insulation
		Inrush	Holding			
24-50/60	24/50	2.18	1.07	26	15/12	Class F Molded
24-50/60	24/60	1.90	.81	19		
120-50/60	120/50	.43	.21	25		
120-50/60	120/60	.38	.16	19		
240-50/60	240/50	.24	.12	30		
240-50/60	240/60	.21	.09	22		

DM Coil: 500RB

Nominal Voltage and Frequency	Applied Voltage and Frequency	Amperes		VA Holding	Watts Max.	Coil Insulation
		Inrush	Holding			
24-50/60	24/50	1.80	.71	17	17/12	Class F Molded
24-50/60	24/60	1.56	.52	12		
120-50/60	120/50	.36	.14	17		
120-50/60	120/60	.31	.10	12		
240-50/60	240/50	.19	.08	19		
240-50/60	240/60	.17	.06	14		

ASC2 Coil: 100RB 240RA 710/713RA

Nominal Voltage and Frequency	Applied Voltage and Frequency	Amperes		VA Holding	Watts Max.	Coil Insulation
		Inrush	Holding			
24-50/60	24/50	1.67	1.10	26	15/12	Class F Molded
24-50/60	24/60	1.41	.83	20		
120-50/60	120/50	.31	.22	26		
120-50/60	120/60	.26	.16	20		
240-50/60	240/50	.17	.13	31		
240-50/60	240/60	.15	.10	23		

DM Coil: 100RB 240RA 710/713RA

Nominal Voltage and Frequency	Applied Voltage and Frequency	Amperes		VA Holding	Watts Max.	Coil Insulation
		Inrush	Holding			
24-50/60	24/50	1.21	.72	17	17/12	Class F Molded
24-50/60	24/60	1.02	.52	13		
120-50/60	120/50	.24	.14	17		
120-50/60	120/60	.20	.10	12		
240-50/60	240/50	.13	.08	20		
240-50/60	240/60	.11	.06	14		

Coils for Solenoid Valves

Ordering Information

AMG - Junction Box

AMC - 1/2" Conduit

AMS - Open Frame



6" Leads



18" Leads



18" Leads or
1.4" Spades

Voltage/Frequency	Description	PCN	Description	PCN	Description	PCN
24V 50/60 Hz	AHG 24V 50/60 Hz	057669	AMC 24V 50/60 Hz	057631	AMF 24V 50/60 Hz	057539
	AMG 24V 50/60 Hz	057341	AHC 24V 50/60 Hz	057736	AMF 24V 50/60 Hz	057538
	--	--	--	--	DMG 24V 50/60 Hz	062013
	DMG 24V 50/60 Hz	055129	--	--	RMF 24V 50/60 Hz	065677
	--	--	--	--	AMS 24V 50/60 Hz	057603
120V 50/60 Hz	AHG 120V 50/60 Hz	057673	AMC 120V 50/60 Hz	057598	RMF 120V 50/60 Hz	065678
	AMG 120V 50/60 Hz	057331	AHC 120V 50/60 Hz	057743	AMS 120V 50/60 Hz	057349
	DMG 120V 50-60 Hz	054762	--	--	RMS 120V 50/60 Hz	065204
208-220/208-240 50/60 Hz	AHG 208-220/208-240 50/60 Hz	057671	AHC 208-220/208-240 50/60 Hz	057741	AMF 208-220/208-240 50/60 Hz	057540
	AMG 208-220/208-240 50/60 Hz	057342	AMC 208-220/208-240 50/60 Hz	057594	RMF 208-220/208-240 50/60 Hz	065679
	DMG 208-220/208-240 50/60 Hz	054764	--	--	AMS 208-220/208-240 50/60 Hz	057531
	--	--	--	--	RMS 208-220/208-240 50/60 Hz	065681
	--	--	--	--	DMS 208-220/208-240 50/60 Hz	063399
480V 50/60 Hz	AMG 480V 50/60 Hz	057527	--	--	AMF 480V 50/60 Hz	057534
120-240V 50/60 Hz	AMG 120-240V 50/60 Hz	057343	AMC 120-240V 50/60 Hz	057730	AMF 120-240V 50/60 Hz	062410
277V 60 Hz	AMG 277V 60 Hz	057528	--	--	AMF 277V 50/60 Hz	057533
	--	--	--	--	AMS 277V 50/60 Hz	057714
12V DC	AMG 12V DC	057521	AMC 12V DC	057596	--	--
24V DC	AMG 24V DC	057523	AMC 24V DC	057633	--	--

Standard Product Offering

ASC2 - DIN



MMG



Voltage/Frequency	Description	PCN	Description	PCN
24V 50/60 Hz	ASC2 24/50-60	062792	--	--
24V 50/60 Hz	ASC2L 24/50-60	063542	--	--
120V 50/60 Hz	ASC2 120/50-60	062462	--	--
120V 50/60 Hz	ASC2 GS-2562-1	015384	--	--
208-220/208-240 50-60 Hz	ASC2 208-240/50-60	062463	--	--
208-220/208-240 50-60 Hz	ASC2 GS-2562-2	015383	--	--
12V	--	--	MMG 12V DC	063524
12V	--	--	MMF 12V DC	062972
24V	ASC2 24V DC	064375	MMG 24V DC	063526

Standard Product Offering

AM and ASC 2 style DC coils should not be used for direct replacements on OEM equipment. The use of this coil on new applications may result in the valve not opening. New applications should use the MM coil because of the significant increase in opening power of the MM Coil over the standard AM and ASC 2 style DC coil.

Coil Enclosure Options

Options	Code
Junction Box	G
Conduit - 18" Leads	C
Open Frame - 18" Leads	F
Open Frame - Spades	S

A	B
120	240
240	480

Dual Voltage Wiring Diagram



Solenoid Multi-Purpose Tool

The Solenoid Multi-Purpose Tool is a magnetic tool that holds key components together as the valve is disassembled. The manual stem adjustment makes it easy to open valves. This tool provides longer life utilizing its spanner wrench which not only makes it easier to service valves, but also protects the enclosing tube from damage.

Features

- Magnet opens a normally closed Emerson solenoid valve that is in the de-energized state
- Incorporates a spanner wrench and drive socket which enable easy disassembly of Emerson solenoid valves 100RB & 240RA/540RA by using a 3/8" socket wrench
- Tool has a manual stem orifice used to manually adjust opening stem
- May reassemble valve with proper torque specifications on collar

Torque Specifications

100RB Series	225 in. lbs.
240RA Series	150 in. lbs.
540RA Series	150 in. lbs.

Ordering Information

PCN	DESCRIPTION
066019	Solenoid Multi-Purpose Tool



Specifications

- Drive Socket size 3/8"

Dimension Data

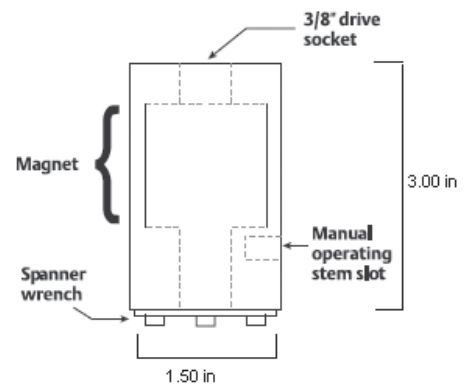

Suction Gas Capacities

Tons					
SUCTION GAS CAPACITIES @ 2 PSI PRESSURE DROP					
VALVE SERIES	Evaporator Temperature - F				
	40	20	0	-20	-40
R-12					
200RB/500RB/200RD 2	0.32	0.30	0.23	0.17	0.10
200RB/500RB/200RD 3	0.44	0.41	0.31	0.23	0.14
200RB/500RB/200RD 4	0.81	0.77	0.59	0.44	0.26
200RB/500RB/200RD 5	0.97	0.93	0.71	0.53	0.32
200RB/500RB/200RD 6	1.05	0.99	0.76	0.56	0.34
200RB/500RB/200RD 7	1.80	1.70	1.30	1.00	0.60
200RB/RD 9	2.05	2.45	1.90	1.40	0.85
240/540RA8	1.00	0.80	0.60	0.50	0.40
240/540RA9T5	1.30	1.10	0.90	0.70	0.50
240/540RA9	1.60	1.30	1.00	0.80	0.60
240/540RA12	2.00	1.60	1.20	1.00	0.70
240/540RA16	3.90	3.20	2.50	1.90	1.50
240/540RA20	5.50	4.50	3.50	2.70	2.10
R-22/R407C					
200RB/500RB/200RD 2	0.34	0.28	0.22	0.18	0.13
200RB/500RB/200RD 3	0.47	0.38	0.31	0.24	0.18
200RB/500RB/200RD 4	0.89	0.73	0.58	0.46	0.34
200RB/500RB/200RD 5	1.08	0.88	0.71	0.55	0.39
200RB/500RB/200RD 6	1.14	0.93	0.75	0.59	0.43
200RB/500RB/200RD 7	1.90	1.00	1.30	1.00	0.76
200RB/RD 9	2.85	2.35	1.91	1.50	1.15
240/540RA8	1.50	1.20	1.00	0.80	0.60
240/540RA9T5	2.00	1.60	1.30	1.00	0.80
240/540RA9	2.40	2.00	1.60	1.20	1.00
240/540RA12	2.90	2.40	1.90	1.50	1.20
240/540RA16	5.80	4.70	3.80	3.00	2.30
240/540RA20	8.20	6.70	5.40	4.20	3.30
R-502					
200RB/500RB/200RD 2	0.28	0.22	0.17	0.13	0.10
200RB/500RB/200RD 3	0.38	0.30	0.24	0.19	0.13
200RB/500RB/200RD 4	0.71	0.57	0.45	0.35	0.26
200RB/500RB/200RD 5	0.86	0.69	0.55	0.42	0.30
200RB/500RB/200RD 6	0.92	0.74	0.58	0.45	0.33
200RB/500RB/200RD 7	1.60	1.30	1.00	0.80	0.60
200RB/RD 9	2.34	1.80	1.50	1.15	0.87
240/540RA8	1.20	1.00	0.80	0.60	0.40
240/540RA9T5	1.60	1.30	1.00	0.80	0.60
240/540RA9	1.90	1.50	1.20	0.90	0.07
240/540RA12	2.30	1.90	1.45	1.10	0.80
240/540RA16	4.60	3.70	2.90	2.30	1.70
240/540RA20	6.50	5.20	4.10	3.20	2.40

NOTE: Capacity is based on largest connection size

Tons					
SUCTION GAS CAPACITIES @ 2 PSI PRESSURE DROP					
VALVE SERIES	Evaporator Temperature - F				
	40	20	0	-20	-40
R-134a					
200RB/500RB/200RD 2	0.26	0.21	0.16	0.11	0.08
200RB/500RB/200RD 3	0.36	0.29	0.21	0.15	0.10
200RB/500RB/200RD 4	0.69	0.54	0.42	0.28	0.16
200RB/500RB/200RD 5	0.83	0.65	0.47	0.34	0.23
200RB/500RB/200RD 6	0.88	0.69	0.52	0.37	0.26
200RB/500RB/200RD 7	1.50	1.20	0.90	0.70	0.50
200RB/RD 9	2.20	1.70	1.35	0.95	0.65
240/540RA8	0.80	0.60	0.50	0.40	0.30
240/540RA9T5	1.40	1.10	0.80	0.60	0.40
240/540RA9	1.70	1.40	1.10	0.80	0.50
240/540RA12	1.90	1.50	1.20	0.90	0.60
240/540RA16	3.20	2.50	1.90	1.40	1.00
240/540RA20	4.40	3.50	2.70	2.00	1.60
R-404A/R-507					
200RB/500RB/200RD 2	0.29	0.23	0.18	0.14	0.10
200RB/500RB/200RD 3	0.39	0.31	0.24	0.19	0.13
200RB/500RB/200RD 4	0.74	0.54	0.46	0.35	0.26
200RB/500RB/200RD 5	0.90	0.71	0.56	0.42	0.30
200RB/500RB/200RD 6	0.95	0.76	0.59	0.45	0.32
200RB/500RB/200RD 7	1.70	1.30	1.00	0.80	0.60
200RB/RD 9	2.40	1.90	1.50	1.10	0.85
240/540RA8	0.90	0.70	0.50	0.40	0.30
240/540RA9T5	1.50	1.20	0.90	0.70	0.50
240/540RA9	1.90	1.50	1.20	0.90	0.60
240/540RA12	2.20	1.80	1.40	1.00	0.80
240/540RA16	3.40	2.70	2.10	1.60	1.20
240/540RA20	4.80	3.80	2.90	2.20	1.60
R-410A					
200RD 2	0.28	0.22	0.20	0.21	0.16
200RD 3	0.57	0.46	0.37	0.29	0.23
200RD 4	1.07	0.88	0.70	0.55	0.43
200RD 5	1.30	1.06	0.85	0.67	0.51
200RD 6	1.37	1.12	0.90	0.72	0.55
200RD 7	2.40	2.00	1.60	1.20	1.00
200RD 9	3.45	2.87	2.30	1.80	1.39

Tons					
SUCTION GAS CAPACITIES @ 2 PSI PRESSURE DROP					
VALVE SERIES	EVAPORATOR TEMPERATURE (°F)				
	0	-10	-20	-30	-40
R-744					
200RD2	0.52	0.49	0.46	0.43	0.39
200RD3	1.07	1.00	0.94	0.87	0.80
200RD4	2.00	1.88	1.76	1.63	1.50
200RD5	2.43	2.29	2.14	1.98	1.82
200RD6	2.56	2.41	2.25	2.09	1.92
200RD7	2.71	2.55	2.39	2.21	2.03
200RD9	6.45	6.08	5.68	5.26	4.83

NOTE: Shading indicates nominal ratings at 20°F Liquid, -20°F Evaporator Temperature, and 25°F Superheat

Liquid Capacities

Tons				
LIQUID CAPACITIES				
Pressure Drop Across Valve - psi				
VALVE SERIES	2	3	4	5
R-12				
100RB	0.80	1.00	1.16	1.20
200RB/500RB/200RD 2	2.28	2.80	3.23	3.61
200RB/500RB/200RD 3	3.04	3.72	4.30	4.80
200RB/500RB/200RD 4	4.95	6.17	7.12	7.97
200RB/500RB/200RD 5	5.20	6.38	7.37	8.24
200RB/500RB/200RD 6	6.01	7.36	8.50	9.50
200RB/500RB/200RD 7	10.75	13.05	15.10	17.05
200RB/RD 9	18.65	23.15	26.05	30.15
240/540RA8	10.00	12.20	14.10	15.80
240/540RA9T (5/8)	14.90	18.20	21.10	23.60
240/540RA9T (7/8, 1 1/8)	19.60	24.00	27.70	31.00
240/540RA12	22.50	27.60	31.80	35.60
240/540RA16	10.00	12.20	14.10	15.80
240/540RA20	14.90	18.20	21.10	23.60
R-22				
100RB	1.04	1.27	1.47	1.64
200RB/500RB/200RD 2	2.94	3.60	4.16	4.65
200RB/500RB/200RD 3	3.92	4.80	5.54	6.19
200RB/500RB/200RD 4	6.49	7.95	9.18	10.26
200RB/500RB/200RD 5	6.71	8.22	9.49	10.61
200RB/500RB/200RD 6	7.74	9.48	10.95	12.24
200RB/500RB/200RD 7	13.50	17.00	18.75	27.85
200RB/RD 9	23.60	29.50	34.10	38.15
240/540RA8	12.70	15.60	18.00	20.10
240/540RA9T (5/8)	19.00	23.30	26.90	30.10
240/540RA9T (7/8, 1 1/8)	24.90	30.50	35.20	39.40
240/540RA12	28.50	34.90	40.30	45.10
240/540RA16	47.40	58.00	67.00	74.90
240/540RA20	77.90	95.40	110.20	123.20
R-502				
100RB	0.70	0.83	1.00	1.10
200RB/500RB/200RD 2	1.93	2.36	2.73	3.05
200RB/500RB/200RD 3	2.57	3.14	3.63	4.06
200RB/500RB/200RD 4	4.15	5.21	6.02	6.73
200RB/500RB/200RD 5	4.50	5.39	6.22	6.69
200RB/500RB/200RD 6	5.08	6.22	7.18	8.03
200RB/500RB/200RD 7	9.22	11.29	13.04	14.57
200RB/RD 9	15.80	19.45	22.15	25.35
240/540RA8	8.20	10.10	11.70	13.00
240/540RA9T (5/8)	12.30	15.10	17.40	19.50
240/540RA9T (7/8, 1 1/8)	16.20	19.80	22.90	25.60
240/540RA12	18.50	22.70	26.20	29.30
240/540RA16	30.80	37.70	43.50	48.70
240/540RA20	50.60	62.00	71.60	80.00

NOTE: Shading indicates ARI standard ratings
 All liquid capacities are based on 40°F Evaporator Temperature and 100°F Liquid Temperature.
 Capacity is based on largest connection size.

Tons						
LIQUID CAPACITIES						
Pressure Drop Across Valve - psi						
VALVE SERIES	2	3	4	5	6	7
R-744						
200RD2	4.36	5.34	6.17	6.90	7.56	8.16
200RD3	5.80	7.11	8.21	9.18	10.1	10.86
200RD4	9.62	11.8	13.6	15.2	16.7	18.01
200RD5	9.95	12.2	14.1	15.7	17.2	18.62
200RD6	11.5	14.1	16.2	18.2	19.9	21.49
200RD7	20.1	24.6	28.4	31.8	34.8	37.62
200RD9	36.2	44.3	51.1	57.2	62.6	67.66

NOTE: Shading indicates nominal ratings at 1°F saturation pressure drop across solenoid valve. All liquid capacities are based on 20°F Liquid and -20°F Evaporating Temperature

Tons				
LIQUID CAPACITIES				
Pressure Drop Across Valve - psi				
VALVE SERIES	2	3	4	5
R-134a				
100RB	0.96	1.20	1.40	1.50
200RB/500RB/200RD 2	2.72	3.33	3.85	4.30
200RB/500RB/200RD 3	3.62	4.44	5.12	5.73
200RB/500RB/200RD 4	6.00	7.35	8.49	9.49
200RB/500RB/200RD 5	6.21	7.60	8.78	9.82
200RB/500RB/200RD 6	7.16	8.77	10.13	11.32
200RB/500RB/200RD 7	12.68	15.93	18.39	20.56
200RB/RD 9	22.50	27.35	32.00	35.65
240/540RA8	12.10	14.80	17.10	19.10
240/540RA9T (5/8)	18.00	22.00	25.50	28.50
240/540RA9T (7/8, 1 1/8)	23.60	28.90	33.40	37.30
240/540RA12	27.10	33.20	38.30	42.80
240/540RA16	45.00	55.10	63.60	71.20
240/540RA20	70.90	86.80	100.30	112.10
R-404A/R-507				
100RB	0.70	0.85	1.00	1.10
200RB/500RB/200RD 2	1.90	2.32	2.68	3.00
200RB/500RB/200RD 3	2.52	3.09	3.57	4.00
200RB/500RB/200RD 4	4.18	5.12	5.92	6.61
200RB/500RB/200RD 5	4.33	5.30	6.12	6.84
200RB/500RB/200RD 6	4.99	6.11	7.06	7.89
200RB/500RB/200RD 7	9.06	11.10	12.81	14.33
200RB/RD 9	14.90	18.25	21.05	24.15
240/540RA8	8.40	10.30	11.90	13.30
240/540RA9T (5/8)	12.50	15.30	17.70	19.80
240/540RA9T (7/8, 1 1/8)	16.40	20.10	23.20	25.90
240/540RA12	18.80	23.00	26.60	29.70
240/540RA16	31.30	38.30	44.20	49.40
240/540RA20	53.60	65.70	75.90	84.80
R-407C				
100RB	1.00	1.21	1.40	1.60
200RB/500RB/200RD 2	2.77	3.39	3.91	4.38
200RB/500RB/200RD 3	3.68	4.51	5.21	5.82
200RB/500RB/200RD 4	6.11	7.48	8.64	9.66
200RB/500RB/200RD 5	6.31	7.73	8.93	9.98
200RB/500RB/200RD 6	7.28	8.92	10.30	11.52
200RB/500RB/200RD 7	13.10	16.15	18.65	20.65
200RB/RD 9	22.85	27.95	32.05	36.15
240/540RA8	12.10	14.80	17.10	19.10
240/540RA9T (5/8)	18.00	22.10	25.50	28.50
240/540RA9T (7/8, 1 1/8)	23.70	29.00	33.50	37.40
240/540RA12	27.10	33.20	38.30	42.90
240/540RA16	45.10	55.20	63.70	71.30
240/540RA20	74.10	90.80	104.80	117.20
R-410A				
200RD 2	2.76	3.38	3.90	4.36
200RD 3	3.67	4.50	5.19	5.80
200RD 4	6.09	7.45	8.61	9.62
200RD 5	6.29	7.71	8.90	9.95
200RD 6	7.26	8.89	10.27	11.48
200RD 7	12.20	15.70	18.10	20.10
200RD 9	22.35	27.75	32.05	36.15
200RD 12	23.75	29.10	33.50	37.60

Discharge Gas Capacities

Tons						
DISCHARGE GAS CAPACITIES						
Pressure Drop Across Valve - psi						
VALVE SERIES	2	5	10	25	50	100
R-12						
100RB	0.10	0.20	0.30	0.50	0.50	0.50
200RB/500RB/200RD 2	0.35	0.50	0.75	1.05	1.20	1.35
200RB/500RB/200RD 3	0.45	0.75	1.00	1.45	1.75	1.85
200RB/500RB/200RD 4	0.85	1.35	1.95	2.70	3.55	4.25
200RB/500RB/200RD 5	1.05	1.65	2.45	3.30	4.45	5.45
200RB/500RB/200RD 6	1.15	1.75	2.50	3.70	4.80	5.85
200RB/500RB/200RD 7	1.50	2.40	3.30	5.20	6.60	7.20
200RB/RD 9	2.80	4.45	6.55	9.35	11.45	10.95
240/540RA8	1.50	2.40	3.30	5.20	6.60	7.20
240/540RA9T5	2.50	4.00	5.60	8.30	10.40	11.20
240/540RA9	3.20	5.00	7.10	10.10	12.10	11.10
240/540RA12	3.50	5.50	7.80	11.70	14.00	12.40
240/540RA16	5.80	9.10	12.90	18.90	23.60	24.30
240/540RA20	8.10	12.80	18.10	28.20	34.40	33.10
R-22						
100RB	0.20	0.30	0.40	0.60	0.80	1.00
200RB/500RB/200RD 2	0.45	0.75	1.05	1.65	2.10	2.40
200RB/500RB/200RD 3	0.65	1.05	1.45	2.25	2.95	3.35
200RB/500RB/200RD 4	1.25	1.95	2.80	4.05	5.50	7.05
200RB/500RB/200RD 5	1.50	1.45	3.50	4.90	6.75	9.00
200RB/500RB/200RD 6	1.60	2.55	3.60	5.50	7.40	9.45
200RB/500RB/200RD 7	2.10	3.40	4.80	7.80	10.40	12.80
200RB/RD 9	4.05	6.25	9.05	14.45	19.00	22.05
240/540RA8	2.10	3.40	4.80	7.80	10.40	12.80
240/540RA9T5	3.60	5.70	8.10	12.50	16.60	20.40
240/540RA9	4.60	7.20	10.20	15.40	20.00	23.10
240/540RA12	5.10	8.00	11.30	18.10	23.40	26.60
240/540RA16	8.30	13.20	18.70	28.60	37.80	45.63
240/540RA20	11.70	18.40	26.10	43.00	56.10	66.00
R-502						
100RB	0.20	0.20	0.30	0.50	0.70	0.80
200RB/500RB/200RD 2	0.40	0.60	0.85	1.35	1.75	2.00
200RB/500RB/200RD 3	0.55	0.85	1.20	1.80	2.35	2.80
200RB/500RB/200RD 4	1.00	1.60	2.25	3.25	4.40	5.75
200RB/500RB/200RD 5	1.20	1.95	2.75	3.95	5.45	7.30
200RB/500RB/200RD 6	1.30	2.05	2.90	4.40	6.00	7.70
200RB/500RB/200RD 7	1.70	2.70	3.80	6.20	8.30	10.40
200RB/RD 9	3.30	5.20	7.35	11.60	15.45	18.30
240/540RA8	1.70	2.70	3.80	6.20	8.30	10.40
240/540RA9T5	2.90	4.50	6.40	10.00	13.30	16.50
240/540RA9	3.60	5.70	8.10	12.30	16.10	18.80
240/540RA12	4.00	6.40	9.00	14.40	18.70	21.70
240/540RA16	6.60	10.50	14.80	22.80	30.20	37.00
240/540RA20	9.30	14.60	20.70	34.30	45.00	53.70

NOTE: Shading indicates ARI standard ratings. Capacity is based on largest connection size.

Tons						
DISCHARGE GAS CAPACITIES						
Pressure Drop Across Valve - psi						
VALVE SERIES	2	5	10	25	50	100
R-134a						
100RB	0.16	0.22	0.35	0.47	0.57	0.64
200RB/500RB/200RD 2	0.40	0.65	0.90	1.30	1.55	1.40
200RB/500RB/200RD 3	0.55	0.85	1.20	1.75	2.15	2.05
200RB/500RB/200RD 4	1.00	1.65	2.30	3.25	4.30	5.20
200RB/500RB/200RD 5	1.25	2.00	2.85	4.00	5.40	6.85
200RB/500RB/200RD 6	1.35	2.15	3.00	4.45	5.80	6.95
200RB/500RB/200RD 7	1.80	2.80	4.00	6.20	8.00	8.90
200RB/RD 9	3.40	5.30	7.60	11.45	14.15	15.25
240/540RA8	1.80	2.80	4.00	6.20	8.00	8.90
240/540RA9T5	3.00	4.70	6.70	10.00	12.70	13.90
240/540RA9	3.80	6.00	8.50	12.20	14.80	14.20
240/540RA12	4.20	6.60	9.40	14.20	17.10	15.90
240/540RA16	6.90	10.90	15.40	22.80	28.60	30.40
240/540RA20	9.70	15.30	21.60	34.00	41.90	41.90
R-404A/R-507						
100RB	0.20	0.30	0.40	0.60	0.70	0.85
200RB/500RB/200RD 2	0.45	0.70	1.00	1.50	1.95	2.25
200RB/500RB/200RD 3	0.60	0.95	1.30	2.00	2.65	3.15
200RB/500RB/200RD 4	1.10	1.75	2.50	3.65	4.95	6.45
200RB/500RB/200RD 5	1.35	2.05	3.00	4.35	5.80	8.15
200RB/500RB/200RD 6	1.45	2.20	3.15	4.45	6.00	8.67
200RB/500RB/200RD 7	1.80	2.90	4.10	5.70	8.90	11.30
200RB/RD 9	3.55	5.75	8.15	13.20	17.30	20.95
240/540RA8	1.80	2.90	4.10	6.70	8.90	11.30
240/540RA9T5	3.10	4.90	6.90	10.70	14.30	17.90
240/540RA9	3.90	6.20	8.70	13.30	17.40	20.20
240/540RA12	4.30	6.80	9.60	15.50	20.30	23.90
240/540RA16	7.10	11.30	16.00	23.60	30.80	36.20
240/540RA20	9.90	15.70	22.20	36.90	48.70	58.90
R-407C						
100RB	0.20	0.30	0.40	0.60	0.80	1.00
200RB/500RB/200RD 2	0.45	0.70	0.95	1.45	1.90	2.25
200RB/500RB/200RD 3	0.60	0.90	1.25	1.95	2.55	3.05
200RB/500RB/200RD 4	1.05	1.70	2.40	3.50	4.75	6.20
200RB/500RB/200RD 5	1.30	2.10	3.00	4.20	5.80	7.85
200RB/500RB/200RD 6	1.40	2.20	3.10	4.75	7.55	8.35
200RB/500RB/200RD 7	2.10	3.30	4.70	7.70	10.30	13.00
200RB/RD 9	3.50	5.50	7.80	12.55	16.70	20.15
240/540RA8	2.10	3.30	4.70	7.70	10.30	13.00
240/540RA9T5	3.60	5.60	8.00	12.40	16.50	20.60
240/540RA9	4.50	7.10	10.10	15.30	20.00	22.50
240/540RA12	6.00	9.50	13.40	21.20	29.60	37.10
240/540RA16	8.20	13.00	18.40	28.40	37.70	46.20
240/540RA20	11.50	18.20	25.70	42.70	56.10	67.20
R-410A						
200RD 2	0.55	0.90	1.30	2.05	2.75	3.40
200RD 3	0.80	1.25	1.75	2.80	3.75	4.70
200RD 4	1.50	2.40	3.35	5.35	6.80	9.10
200RD 5	1.85	2.95	4.25	6.75	8.30	11.30
200RD 6	2.00	3.10	4.35	6.85	9.25	12.25
200RD 7	2.30	3.55	5.00	7.80	9.80	13.00
200RD 9	4.90	7.80	11.05	17.60	24.15	30.60

Tons					
DISCHARGE GAS CAPACITIES					
Pressure Drop Across Valve - psi					
VALVE SERIES	2	5	10	25	50
R-744					
200RD2	0.80	1.26	1.77	2.74	3.73
200RD3	1.16	1.83	2.57	3.98	5.43
200RD4	2.18	3.43	4.82	7.46	10.18
200RD5	2.69	4.23	5.95	9.21	12.6
200RD6	2.91	4.58	6.43	9.95	13.6
200RD7	3.34	5.26	7.39	11.4	15.6
200RD9	7.12	11.2	15.7	24.4	33.3

NOTE: Shading indicates nominal ratings based on 30°F Condensing with 50°F Superheat at compressor discharge, 20°F Liquid, -20°F Evaporator and 25°F Superheat at compressor suction.

Our Industrial Solenoid Valves are approved for use with the fluids utilized in secondary loops such as Ethylene and Propylene Glycol and Tyfoxit. The recommended seat material is Buna-N.

In addition to air, water and steam, the following is a listing of secondary loop fluids that are compatible with our valves:

These valves referenced above are as follows:

202CB	211CA
203CA	214CA
204CD	222CB
210CA	314UB

Fluid Name	Manufacturer
Ethylene & Propylene Glycol	Various
Tyfoxit	Spauschus Associates (Distributor)
Siltherm XLT	DOW
HFE	3M
Dowfrost	Dow
Pekasol	Unknown
Dynalene	Dynalene

When ordering valves for the above stated application, be sure to mention the Elastomer Code "B" which designates Buna-N.

Nomenclature example: 222CB 1/2 B 1/2 B

2	22	C	B	1/2	B	1/2	B
Valve Type 2 = 2 Way 3 = 3 Way	Product Group Two digits to Define Group	Form of Flow C = Normally Closed O = Normally Open U = Universal	Design Series Letter will be advanced to identify product changes	Pipe N.P.T. 1/8" thru 2" GS indicates non-standard	Body Material B = Brass S = Stainless Steel T = Stainless Steel with Silver Shading Band	Body Orifice 3/65" thru 2"	Elastomer Code B = Buna-N

202CB

The 202CB is a direct-acting, normally closed valve for control of air, water, and steam applications.

Features

- Superior life with stainless steel enclosing tube
- Repair kits available

Options

- Brass or stainless steel bodies
- Optional Voltages: 12 or 24 VDC & 120-240, 480 & 240-480/50-60 Hz



Specifications

- 1/8" NPT Solenoid Valve
- Watts: 12 A.C., 15 D.C.
- VA Inrush: 28
- VA Holding: 19
- Maximum working pressure: 500 psi (1000 psi - 3/64" orifice only)
- Weight: 1 lb
- Standard Voltages: 24, 120, 208-240/50-60 Hz
- UL/CUL file number: MP604

Ordering Information*

Pipe Size	Orifice Size	M.O.P.D ²		Cv	Max. AC Fluid Temp. ¹	Recommended Coils			Description	PCN	Elastomer
		AC	DC			Size	Insulation	Enclosure			
Brass General Purpose											
1/8	3/64	500	500	0.05	180°F	A 12 Watts AC 15 Watts DC	M Class F Molded	G Junction Box	202CB1/8B3/64B		BUNA-N
	1/16	500	500	0.12					202CB1/8B1/16B		
	3/32	300	125	0.22					202CB1/8B3/32B		
	1/8	150	75	0.34					202CB1/8B1/8B	030113	
	5/32	100	40	0.48					202CB1/8B5/32B	030114	
Stainless Steel General Purpose											
1/8	3/64	500	500	0.05	180°F	A 12 Watts AC 15 Watts DC	M Class F Molded	G Junction Box	202CB1/8S3/64B		BUNA-N
	1/16	500	500	0.12					202CB1/8S1/16B	064756	
	3/32	300	125	0.22					202CB1/8S3/32B		
	1/8	150	75	0.34					202CB1/8S1/8B		
	5/32	100	40	0.48					202CB1/8S5/32B		
Brass Steam											
1/8	1/16	150	-	0.12	400°F	A 12 Watts	H Class H Molded	G Junction Box	202CB1/8B1/16T		PTFE w/Ethylene Propylene Gaskets
	3/32	150	-	0.22					202CB1/8B3/32T		
	1/8	150	-	0.34					202CB1/8B1/8T	030123	
	5/32	100	-	0.48					202CB1/8B5/32T		
1/8	1/8	150	-	0.34	400°F	A 12 Watts	H Class H Molded	G Junction Box	202CB1/8B1/8P	030118	Ethylene Prop.
1/8	5/32	100	-	0.48	400°F	A 12 Watts	H Class H Molded	G Junction Box	202CB1/8B5/32V	056954	Viton w/ Ethylene Propylene Gasket

¹With an ambient temperature of 77°F.

²Maximum Operating Pressure Differential.

*VLC - See coil assemblies for availability.

Standard Product Offering

202CB

Dimensional Data (in)

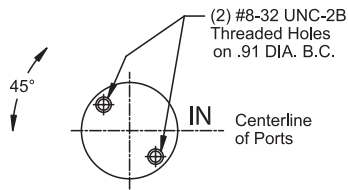
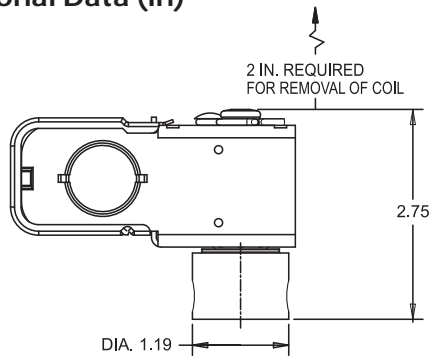

Exploded View

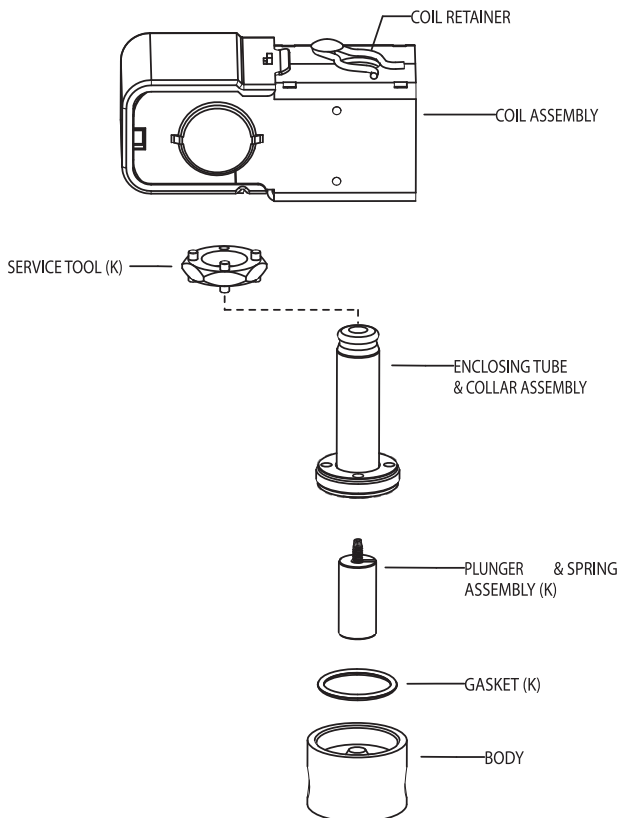

Valve Repair Kit

K indicates part is supplied in valve repair kit.

Coil Assembly

See coil assemblies for availability..

Valve Options

Options	To Order
Manual Override (not for steam) Minimum order qty. 100	Add suffix "M" to catalog number.
Adjustable Metering (not for steam) 500 psi SWP for All orifice sizes.	Add suffix "A" to catalog number.
Silver Shading Band (on stainless steel valves)	Change body material code. Example: Change standard 202CB1/8S to non-standard 202CB1/8T (silver shading band)

Valve Repair Kits

Seat Material	Kit #	PCN
Buna-N	K-1063	066046
Viton	K-1065	066043
Rulon	K-1068	032396
Ethylene Propylene	K-1064	021104

Standard Product Offering

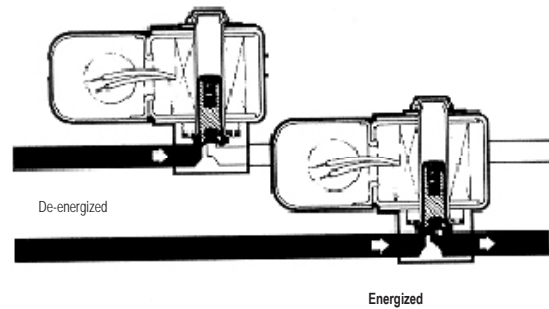

203CA

The 203CA is a direct-acting, 2-way normally closed valve for air, water and steam applications.

Features

- Superior life with stainless steel enclosing tubes
- Forged brass body with large wrench flats
- Repair kits available



Options

- Optional Voltages: 120-240, 480 & 240-480/50-60 Hz

Specification:

- 3/8" NPT Solenoid Valve
- Watts: 12 A.C.
- VA Inrush: 37 for 5/32 & 1/8 orifices
47 for 1/4 + orifices
- VA Holding: 19
- Maximum working pressure: 500 psi
- Weight: 1 lb. 4 oz.
- Standard Voltages: 24, 120, 208-240/50-60 Hz
- UL/CUL file number: MP604

Ordering Information *

Pipe Size	Orifice Size	M.O.P.D ²	Cv	Max. AC Fluid Temp. ¹	Recommended Coils			Description	PCN	Elastomer
		AC			Size	Insulation	Enclosure			
Brass General Purpose										
3/8	1/8	125	0.3	180°F	A 12 Watts AC	M Class F Molded	G Junction Box	203CA3/8B1/8B		BUNA-N
	5/32	75	0.5					203CA3/8B5/32B		
	1/4	25	1.0					203CA3/8B1/4B	030603	
	5/16	15	1.5					203CA3/8B5/16B		
	3/8	10	1.7					203CA3/8B3/8B	030605	
Stainless Steel General Purpose										
3/8	1/4	15	1.0	250°F	A 12 Watts AC	M Class F Molded	G Junction Box	203CA3/8B1/4P		Ethylene Propylene Gaskets
	5/16	15	1.5					203CA3/8B5/16P		
	3/8	10	1.7					203CA3/8B3/8P	030614	

¹With an ambient temperature of 77°F.

²Maximum Operating Pressure Differential.

*VLC - See coil assemblies for availability.

Standard Product Offering

203CA

Dimensional Data (in)

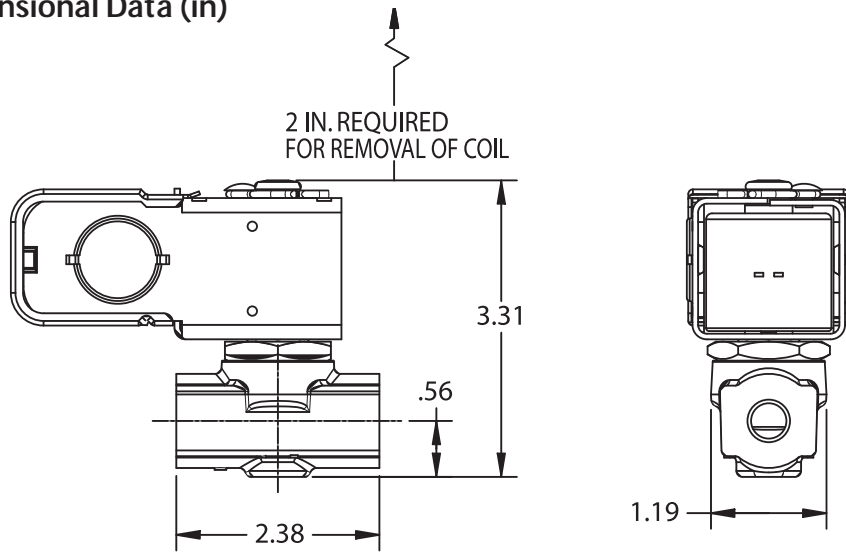

Exploded View

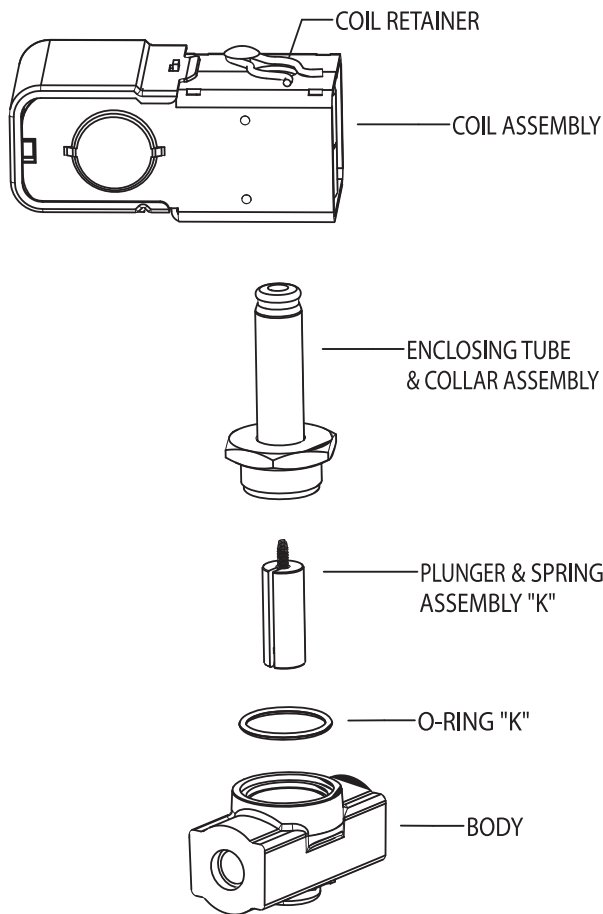

Valve Repair Kits

Orifice Size	Seat Material	Kit #	PCN
1/4, 5/16, 3/8	Buna-N	K-1104	021108
	Ethylene Propylene	K-1106	040598

Standard Product Offering

Valve Repair Kit
 K indicates part is supplied in valve repair kit.
Coil Assembly
 See coil assemblies for availability.

204CD

The 204CD is a direct-acting unidirectional, normally closed valve for air, water and steam applications.

Features

- Superior life with stainless steel enclosing tubes
- Repair kits available

Options

- Brass or stainless steel bodies
- Optional Voltages: 12 or 24 VDC & 120-240, 480 & 240-480/50-60 Hz

Specifications

- 1/4" NPT Solenoid Valve
- Watts: 12 A.C., 15 D.C.
- VA Inrush: 31
- VA Holding: 19
- Maximum working pressure: 500 psi
- Weight: 1 lb. 3 oz.
- Standard Voltages: 24, 120, 208-240/50-60 Hz
- UL/CUL file number: MP604



Ordering Information*

Pipe Size	Orifice Size	M.O.P.D ²		Cv	Max. AC Fluid Temp. ¹	Recommended Coils			Description	PCN	Elastomer
		AC	DC			Size	Insulation	Enclosure			
Brass General Purpose											
1/4	3/64	500	500	0.05	180°F	A 12 Watts AC 15 Watts DC	M Class F Molded	G Junction Box	204CD1/4B3/64B	030731	BUNA-N
	1/16	500	500	0.12					204CD1/4B1/16B		
	3/32	300	125	0.22					204CD1/4B3/32B	030733	
	1/8	150	75	0.34					204CD1/4B1/8B	056110	
	5/32	100	40	0.48					204CD1/4B5/32B	030735	
	3/16	60	30	0.56					204CD1/4B3/16B	030736	
	1/4	20	10	0.70					204CD1/4B1/4B	030737	
Stainless Steel General Purpose											
1/4	3/64	500	500	0.05	180°F	A 12 Watts AC 15 Watts DC	M Class F Molded	G Junction Box	204CD1/4S3/64B		BUNA-N
	1/16	500	500	0.12					204CD1/4S1/16B		
	3/32	300	125	0.22					204CD1/4S3/32B	030870	
	1/8	150	75	0.34					204CD1/4S1/8B	030871	
	5/32	100	40	0.48					204CD1/4S5/32B		
	3/16	60	30	0.56					204CD1/4S3/16B		
	1/4	20	10	0.70					204CD1/4S1/4B	030874	
Brass Steam											
1/4	3/64	150	-	0.05	400°F	A 12 Watts AC A	H Class H Molded M	G Junction Box G	204CD1/4B3/64T		PTFE w/Ethylene Propylene Gaskets
	1/16	150	-	0.12					204CD1/4B1/16T		
	3/32	150	-	0.22					204CD1/4B3/32T	030748	
	1/8	150	-	0.34					204CD1/4B1/8T	030749	
	5/32	100	-	0.48					204CD1/4B5/32T	030750	
	3/16	60	-	0.56					204CD1/4B3/16T		
	1/4	20	-	0.70	250°F			204CD1/4B1/4P		E.P. Seat	
Stainless Steel Steam											
1/4	3/64	150	-	0.05	400°F	A 12 Watts AC A	H Class H Molded M	G Junction Box G	204CD1/4S3/64T	030883	PTFE w/Ethylene Propylene Gaskets
	1/16	150	-	0.12					204CD1/4S1/16T		
	3/32	150	-	0.22					204CD1/4S3/32T		
	1/8	150	-	0.34					204CD1/4S1/8T	030886	
	5/32	100	-	0.48					204CD1/4S5/32T		
	3/16	60	-	0.56					204CD1/4S3/16T	030888	
	1/4	20	-	0.70	250°F			204CD1/4S1/4P		E.P. Seat	
Stainless Steel Steam											
1/4	5/32	100	-	0.48	400°F	A 12 Watts	H Class H Molded	G Junction Box	204CD1/4S5/3P	053492	E.P. Seat
Brass Steam											
1/4	5/32	100	-	0.48	400°F	A 12 Watts	H Class H Molded	G Junction Box	204CD 1/4 B 5/32 P	064682	E.P. Seat

¹With an ambient temperature of 77°F.

²Maximum Operating Pressure Differential.

*VLC - See coil assemblies for availability.

Standard Product Offering

204CD

Dimensional Data (in)

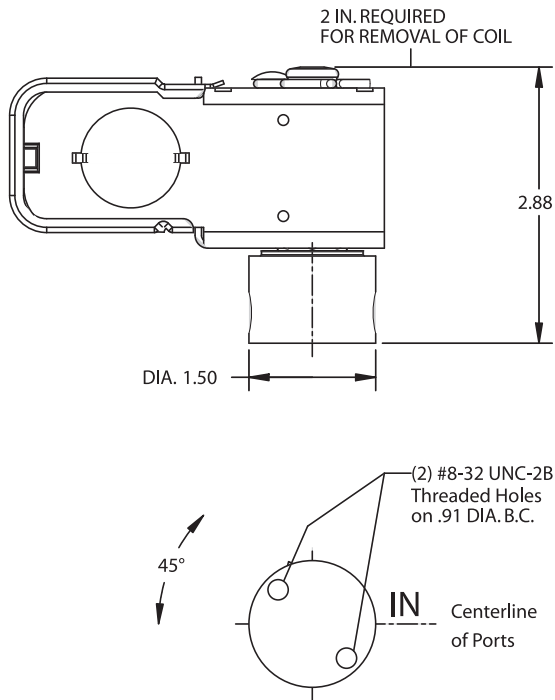

Valve Options

Options	To Order
Manual Override (not for steam) Minimum order qty. 100	Add suffix "M" to catalog number.
Adjustable Metering (not for steam) 500 psi SWP for All orifice sizes.	Add suffix "A" to catalog number.
Silver Shading Band (on stainless steel valves)	Change body material code. Example: Change standard 204CD1/4S to non-standard 204CD1/4T (silver shading band)

Valve Kit Repairs

Seat Material	Kit #	PCN
Buna-N	K-1072	021105
Viton	K-1074	021106
Rulon	K-1077	021107
Ethylene Propylene	K-1076	032154
Buna-N (1/4 orifice only)	K-1162	039145

Exploded View

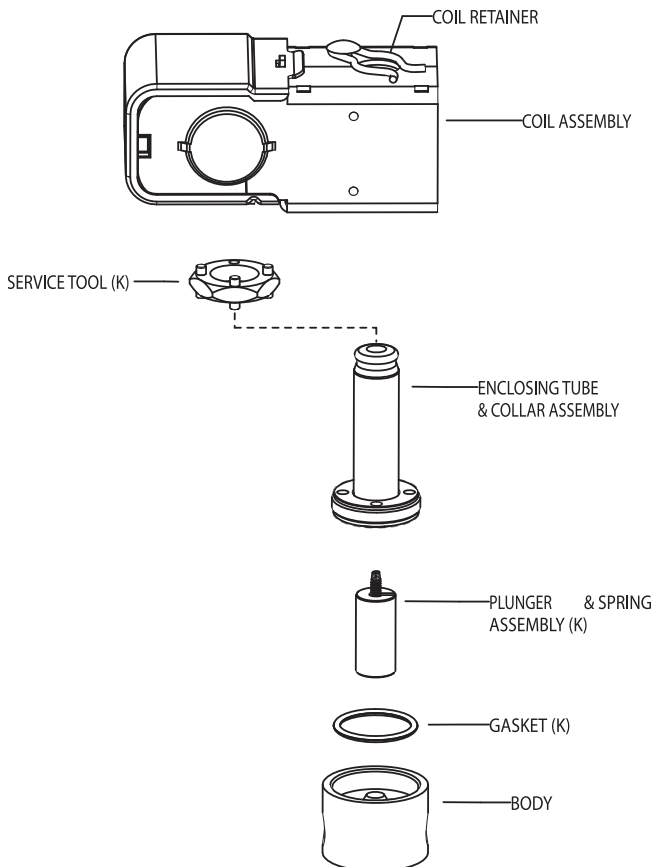

Valve Repair Kit

"K" indicates part is supplied in valve repair kit.

Coil Assembly

For available coil assemblies, see page 126.

210CA/211CA

The 210CA/211CA is a 2-way normally closed valve used in air, water and steam applications. The 210CA valve is pilot-operated and the 211CA valve is direct-acting.

Features

- Unique captive diaphragm and seal
- Superior life with stainless steel enclosing tube
- Repair kits available



3/8", 1/2", 3/4"



1" Only

Options

- Optional Voltages: 12 or 24 VDC & 120-240, 480 & 240-480/50-60 Hz

Specifications

- Watts: 12 A.C.
- VA Inrush: 31
- VA Holding: 19
- Maximum working pressure: 300 psi (250 psi on 1" 210C only)
- Weight: 1 lb. 3 oz.
- Standard Voltages: 24, 120, 208-240/50-60 Hz
- Diaphragm Operated Solenoid Valve:
 - 210CA - from 5 to 150 psi. 3/8" to 1" NPT
 - 211CA - from 0 to 100 psi. 3/8" to 3/4" NPT
- UL/CUL file number: MP604

210CA Ordering Information*

Pipe Size	Orifice Size	M.O.P.D		Cv	Max. AC Fluid Temp. ¹	Recommended Coils			Description	PCN	Elastomer
		AC				Size	Insulation	Enclosure			
Brass General Purpose											
3/8	5/8	150		2.8	180°F	A 12 Watts AC	M Class F Molded	G Junction Box	210CA3/8B5/8B	030619	BUNA-N
1/2	5/8	150		3.6					210CA1/2B5/8B	030620	
3/4	3/4	125		5.5					210CA3/4B3/4B	030621	
1	1	125		13					210CA1B1B	038629	
Brass-Hot Water (210°F) or Steam (TO 250°)											
3/8	5/8	100 ²	15 ³	2.8	250°F	A 12 Watts AC	M Class F Molded	G Junction Box	210CA3/8B5/8P		Ethylene Propylene
1/2	5/8	100 ²	15 ³	3.6					210CA1/2B5/8P	030623	
3/4	3/4	100 ²	15 ³	5.5					210CA3/4B348P	030624	

211CA Ordering Information*

Pipe Size	Orifice Size	M.O.P.D		Cv	Max. AC Fluid Temp. ¹	Recommended Coils			Description	PCN	Elastomer
		AC				Size	Insulation	Enclosure			
Brass General Purpose											
3/8	5/8	100		2.8	180°F	A 12 Watts AC	M Class F Molded	G Junction Box	211CA3/8B5/8B	030625	BUNA-N
1/2	5/8	100		3.6					211CA1/2B5/8B	030626	
3/4	3/4	100		5.5					211CA3/4B3/4B	030627	
Brass-Hot Water (210°F) or Steam (TO 250°)											
3/8	5/8	100 ²	15 ³	2.8	250°F	A 12 Watts AC	M Class F Molded	G Junction Box	211CA3/8B5/8P	032303	Ethylene Propylene
1/2	5/8	100 ²	15 ³	3.6					211CA1/2B5/8P	032304	
3/4	3/4	100 ²	15 ³	5.5					211CA3/4B348P	032305	

¹With an ambient temperature of 77°F.

²MOPD-Hot Water

³MOPD-Steam

*VLC - See coil assemblies for availability.

Standard Product Offering

210CA/211CA

Dimensional Data (in)

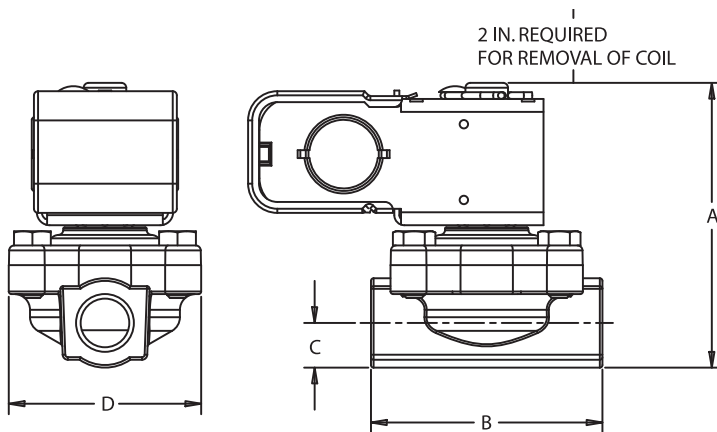

Pipe Size	A	B	C	D
3/8	3.56	2.75	0.53	2.29
1/2				
3/4	3.83	2.81	0.66	4.31
1*	4.55	4.16	0.84	

* 1" Pipe available on 210C valve only.

Exploded View

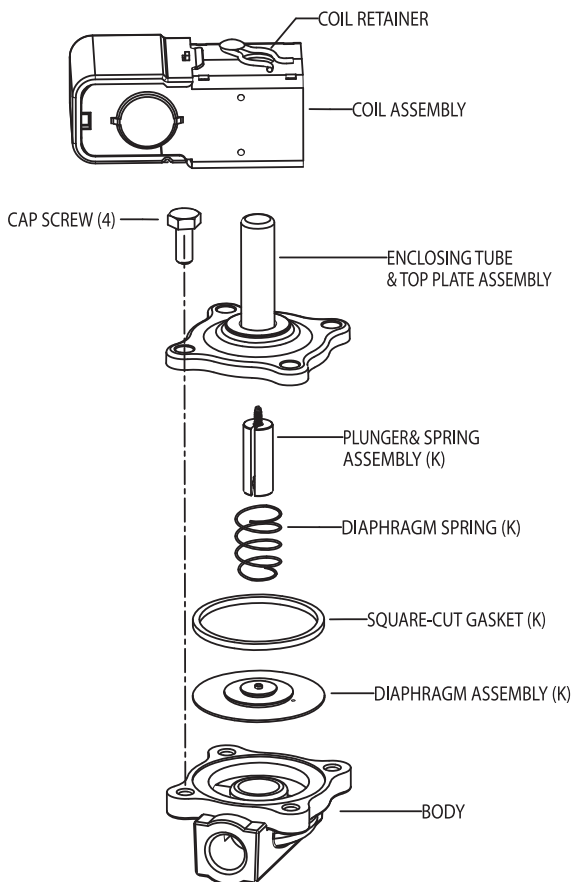

210CA Valve Repair Kits

Seat Material	Connection Size					
	3/8 & 1/2	PCN	3/4	PCN	1	PCN
Buna-N	K-1155	028964	K-1231	045072	K-1177	038934
Ethylene Propylene	K-1156	029856	K-1232	045083		

Standard Product Offering

211CA Valve Repair Kits

Seat Material	Kit #	PCN
Buna-N	K-1157	034357
Ethylene Propylene	K-1158	039879

Standard Product Offering

Valve Repair Kit

K indicates part is supplied in valve repair kit.

Coil Assembly

See coil assemblies for availability.

214CB

The 214CB is a 2-way normally closed valve for air, water, and steam applications.

Features

- Superior life with stainless steel enclosing tube
- Forged brass body with large wrench flats
- PTFE O-ring for superior external leakage
- Repair kits available



Options

- Optional Voltages: 480, 120-240 & 240-480/50-60 Hz

Specifications

- 1/4" & 3/8" NPT Solenoids
- Watts: 12 @ 60Hz
- VA Inrush: 44
- VA Holding: 22
- Maximum working pressure: 350 psi
- Weight: 1 lb. 4 oz.
- Standard Voltages: 24, 120, 208-240/50-60 Hz
- Pilot Operated: 2 to 200 P.S.I.
- UL/CUL file number: MP604

Ordering Information*

Pipe Size	Orifice Size	M.O.P.D ²	Cv	Max. AC Fluid Temp. ¹	Recommended Coils			Description	PCN	Elastomer
		AC			Size	Insulation	Enclosure			
Brass General Purpose										
1/4	1/4	200	1.2	180°F	A 12 Watts @ 60 Hz	M Class F Molded	G Junction Box	214CB1/4B1/4B	030540	BUNA-N
	5/16	200	1.6					214CB1/4B5/16B	030541	
	3/8	200	2.2					214CB1/4B3/8B		
3/8	1/4	200	1.2					214CB3/8B1/4B		
	5/16	200	1.6					214CB3/8B5/16B		
	3/8	200	2.2					214CB3/8B3/8B	030545	
3/8	3/8	200	2.2	400°F	Same As Above			214CB 3/8B3/8P	030557	EP Seat

¹With an ambient temperature of 77°F.

²Maximum Operating Pressure Differential.

*VLC - See coil assemblies for availability.

Standard Product Offering

214 CB

Dimensional Data (in)

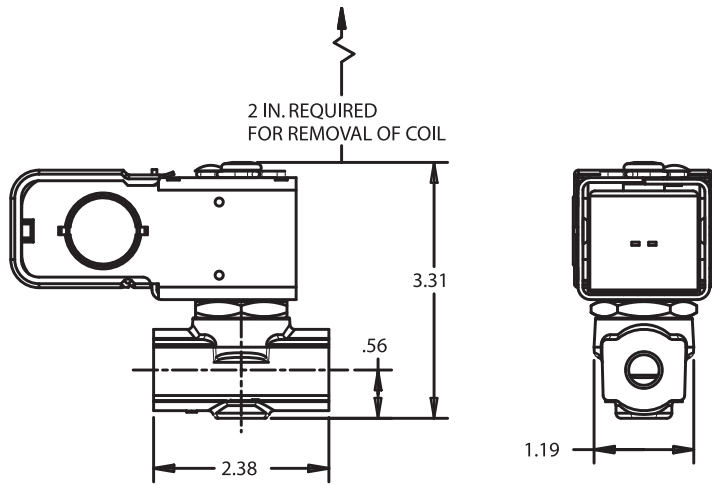

Exploded View

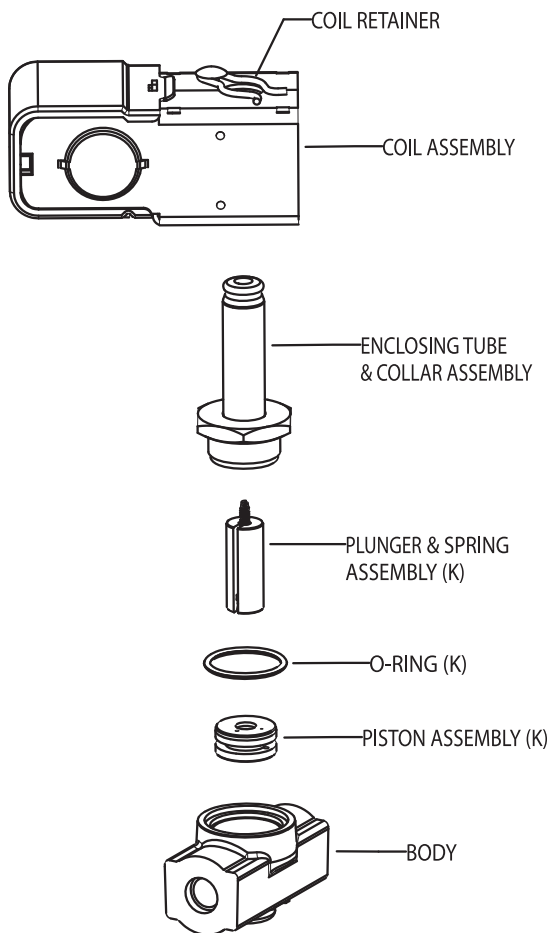

Valve Repair Kit

Valve Repair "K" indicates part is supplied in valve repair kit.

Coil Assemblies

See coil assemblies for availability.

Valve Options

Options	To Order
Manual Override	Add suffix "M" to catalog number.

Valve Repair Kits

Seat Material	Kit #	PCN
Buna-N	K-1112	035074
Ethylene Propylene	K-1113	041334

Standard Product Offering

222CB

The 222CB is a 2-way normally closed valve for air, water, and steam applications.

Features

- Forged brass body with large wrench flats
- Repair kits available

Options

- Optional Voltages: 480, 120-240 & 240-480/50-60 Hz



Specifications

- 3/8" & 1 1/2" NPT Solenoids
- Rulon Seat Material
- Watts: 12 @ 60Hz
- VA Inrush: 38
- VA Holding: 19
- Maximum working pressure: 300 psi
- Minimum Operating Pressure Differential : 5 psi
- Standard Voltages: 24, 120, 208-240/50-60 Hz
- UL/CUL file number: MP604

• Weights:	Pipe Size	
	3/8, 1/2	1 lb. 8 oz.
	3/4	3 lbs.
	1	4 lbs. 4 oz.
	1-1/4	6 lbs. 2 oz.
	1-1/2	8 lbs. 6 oz.

Ordering Information*

Pipe Size	Orifice Size	M.O.P.D ²	Cv	Max. AC Fluid Temp. ¹	Recommended Coils			Description	PCN	Elastomer
		AC			Size	Insulation	Enclosure			
Brass General Purpose										
3/8	1/2	250	3.5	180°F	A 12 Watts @ 60 Hz	M Class F Molded	G Junction Box	222CB3/8B1/2B		BUNA-N
1/2	1/2		222CB1/2B1/2B					039917		
3/4	3/4		222CB3/4B3/4B					028192		
1	1		222CB1B1B					039931		
1-1/4	1-1/4		222CB1-1/4B1-1/4B					039918		
1-1/2	1-1/2		222CB1-1/2B1-1/2B					038879		
Brass Steam										
1/2	1/2	150	3.5	400°F	A 12 Watts @ 60 Hz	H Class F Molded	G Junction Box	222CB1/2B1/2T	037958	Rulon with Ethylene Propylene Gaskets
3/4	3/4		222CB3/4B3/4T					039930		
1	1		222CB1B1T					039834		
1-1/4	1-1/4		222CB1-1/4B1-1/4T					040532		
1-1/2	1-1/2		222CB1-1/2B1-1/2T					040582		
Brass Steam										
3/4	3/4	150	7.0	400°F	Same As Above			222CB- 3/4 B-3/4 P	041314	Ethylene Prop.

¹With an ambient temperature of 77°F.

²Maximum Operating Pressure Differential.

*VLC - See coil assemblies for availability.

Standard Product Offering

222CB

222CB Dimensional Data (in)

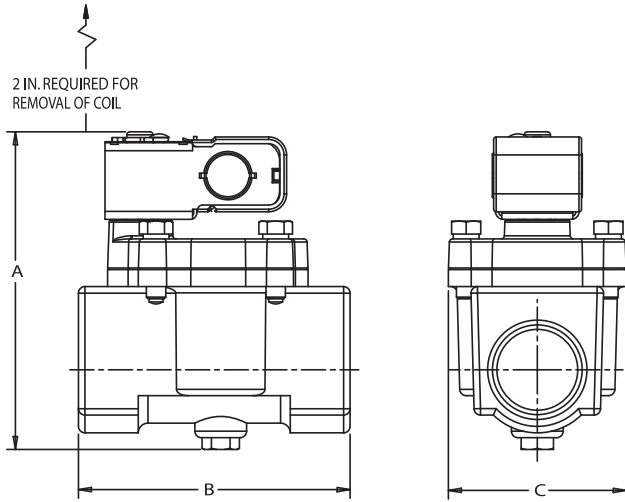

Orifice Size	A*	B	C
1/2	4.59	2.47	1.63
3/4	4.91	3.25	2.06
1	5.38	4.06	2.63
1 1/4	5.66	4.56	3.00
1 1/2	6.16	5.25	3.44

* Add 0.97 for Manual Override

Valve Options

Options	To Order
Manual Override (not for steam) Field Installed	Add suffix "M" to catalog number.

222CB Valve Repair Kits

Seat Material	Orifice Size - NPT									
	3/8 & 1/2		3/4		1		1-1/4		1-1/2	
	PCN		PCN	PCN		PCN		PCN		PCN
Buna-N	K-1116	030765	K-1120	037558	K-1124	028955	K-1128	031349	K-1132	028956
Rulon	K-1118	029235	K-1122	021109	K-1126	034178	K-1130	034047		
Ethylene Propylene			K-1121	040680						

Exploded View

Standard Product Offering

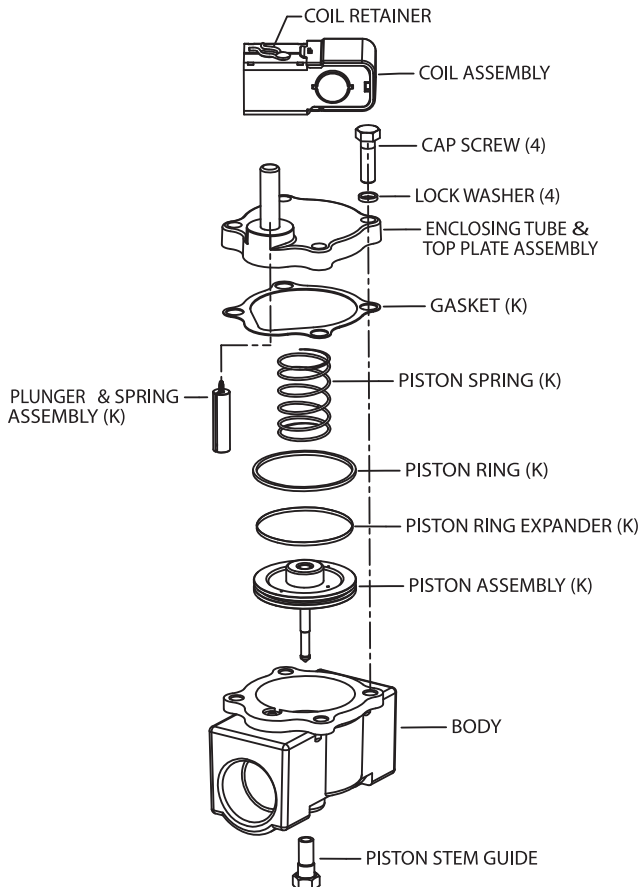

Valve Repair Kit

K indicates part is supplied in valve repair kit.

Coil Assembly

See coil assemblies for availability.

314UB

The 314UB is a direct-acting, 3-way universal valve for air and water applications.

Features

- Rugged industrial construction
- Both seat discs are spring loaded
- Superior life with stainless steel enclosing tube

Options

- Brass or stainless steel bodies
- Optional Voltages: 480, 120-240 & 240-480/50-60 Hz

NOTE: 314U valves require an AMGN, EM or ASC-Type coil.

Specifications

- 1/4" NPT Solenoids
- Watts: 12 @ 60Hz
- VA Inrush: 36
- VA Holding: 24
- Maximum working pressure: 500 psi
- Weight: 1 lb.
- Standard Voltages: 24, 120, 208-240/50-60 Hz
- UL/CUL file number: MP604



Ordering Information*

Pipe Size	Orifice Size	M.O.P.D ²			Max. AC Fluid Temp. ¹	Recommended Coils			Description	PCN	Elastomer
		AC	Port 2	Port 3		Size	Insulation	Enclosure			
Brass General Purpose											
1/4	3/64	125	.05	.06	180°F	A	M	GN	314UB1/4B3/64B3/64B	030722	BUNA-N
	3/32	40	.22	.17		12 Watts @ 60 Hz	Class F Molded	Junction Box	314UB1/4B3/32B3/32B	030719	
Stainless Steel General Purpose											
1/4	3/64	125	.05	.06	180°F	A	M	GN	314UB1/4S3/64B3/64B	030725	BUNA-N

¹With an ambient temperature of 77°F.

²Maximum Operating Pressure Differential.

*VLC - See coil assemblies for availability.

Standard Product Offering

314UB

Dimensional Data (in)

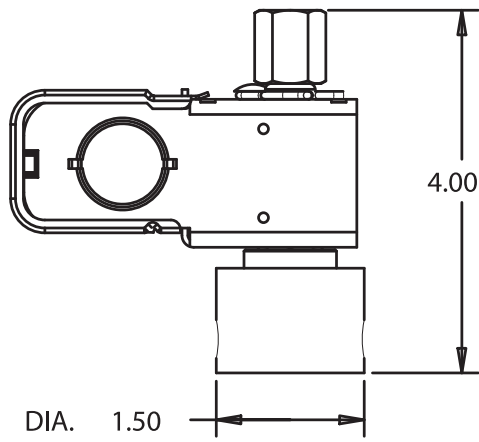

Valve Options

Options	To Order
Silver Shading Band (on stainless steel valves)	Change body material code. Example: Change standard 314UB1/8S to non-standard 314UB1/bT (silver shading band)

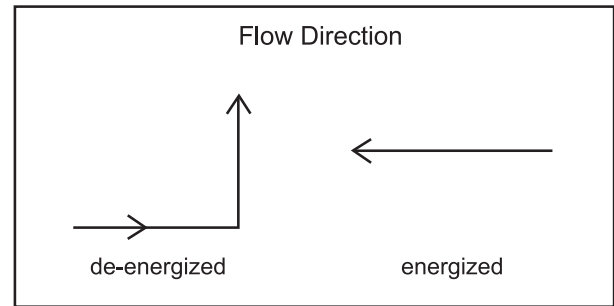

Exploded View

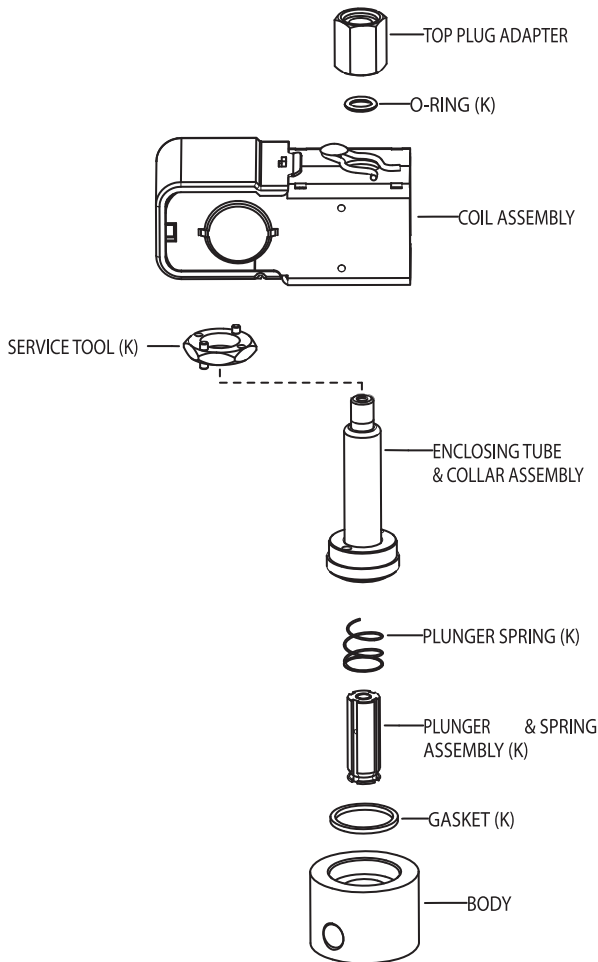

Valve Repair Kit

Seat Material	Kit #	PCN
Buna-N	K-1093	037054

Valve Repair Kit

K indicates part is supplied in valve repair kit.

Coil Assembly

See coil assemblies for availability.

Old to New Cross Reference

Old Model	Old PCN	New Model	New PCN
121WB5CP02	030038	204CD 1/4B 5/32 B VLC	030735
121WB03P02	040412	204CD 1/4B 3/16 B VLC	030736
121WB04P02	040337	204CD 1/4B 1/4 B VLC	030737
121SB5CP02	040300	204CD 1/4B 5/32 T VLC	030750
201WB04P02	091876	214CB 1/4B 1/4 B VLC	030540
201WB05P02	040758	214CB 3/8B 5/16 B VLC	064854
201WB06P02	065610	214CB 3/8B 3/8 B VLC	030545
231WB08P04	030051	222CB 1/2 B 1/2 B VLC	039917
231WB12P06	039987	222CB 3/4 B 3/4 B VLC	028192
231WB16P08	034211	222CB 1 B 1 B VLC	039931
231WB20P10	040283	222CB 1-1/4 B 1-1/4 B VLC	039918
231WB24P12	040021	222CB 1-1/2 B 1-1/2 B VLC	038879
231SB08P04	034171	222CB 1/2 B 1/2 T VLC	037958
231SB12P06	040069	222CB 3/4 B 3/4 T VLC	039930
231SB16P08	030048	222CB 1 B 1 T VLC	039834
231SB20P10	040365	222CB 1-1/4 B 1-1/4 T VLC	040532
231SB24P12	040366	222CB 1-1/2 B 1-1/2 T VLC	040582
241WA10P03	035073	210CA 3/8 B 5/8 B VLC	030619
241WA10P04	035023	210CA 1/2 B 5/8 B VLC	030620
241WA12P06	035022	210CA 3/4 B 3/4 B VLC	030621
241WA16P08	038857	210CA 1 B 1 B VLC	038629

Standard Product Offering

ACK Check Valves

R-410A

The ACK check valve is a normally closed magnetic check valve that prevents reverse refrigerant flow in liquid lines and compressor discharge lines.



Features

- Copper Connection Sizes 1/4" through 2-5/8"
- Hermetic Spun Copper Design
- Magnetic Checking Action
- Built-In 30 Mesh Stainless Steel Strainer
- Can Be Installed In Any Position

Specifications

- UL/CUL File number: SA 5312

Dimensional Data

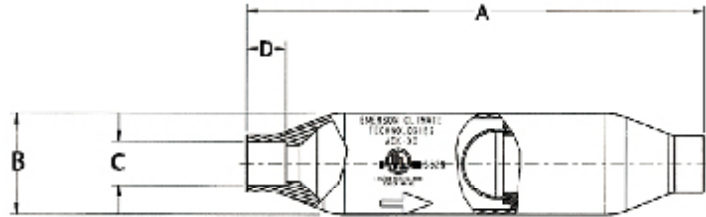

Nomenclature example: ACK-4

ACK	4
Check Valve Series	Copper ODF Connection Size (in 1/16")

Ordering Information and Dimensional Data (in)

PCN	Description	Connection Size	A	B	C	D	Opening Pressure (oz/sq in)	Opening Pressure (psig)	MWP (psig)	Nominal Tons R-22 Suction 40°F @ 1 psi	Nominal Tons R-22 Liquid 40°F @ 1 psi	Cv
064985	ACK-4	1/4 ODF	4.00	0.88	0.254 ± 0.002	0.19	1.20	0.08	800	0.40	2.60	0.9
064986	ACK-6	3/8 ODF			0.379 ± 0.002	0.40	1.30	0.08		0.60	3.10	1.0
064987	ACK-8	1/2 ODF	5.00	1.13	0.504 ± 0.002	0.31	3.50	0.22	680	1.20	9.40	3.1
064988	ACK-10	5/8 ODF			0.629 ± 0.002	0.50				1.40	13	3.6
064989	ACK-12	3/4 ODF	7.00	1.63	0.754 ± 0.002	0.63	3.80	0.24	680	3.30	27	8.0
064990	ACK-14	7/8 ODF			0.879 ± 0.003	0.42				3.70	29	9.2
064991	ACK-18	1-1/8 ODF	8.38	2.13	1.130 ± 0.003	0.94	6.80	0.43	680	6	51	15.4
064992	ACK-22	1-3/8 ODF	9.38	2.63	1.380 ± 0.003	1.04	10.20	0.64	680	9.50	79	23.8
064993	ACK-26	1-5/8 ODF	10.50	3.13	1.630 ± 0.003	1.07	11.40	0.71	680	17	102	24.2
064994	ACK-34	2-1/8 ODF	12.00	3.63	2.130 ± 0.003	1.34	18.10	1.13	680	30	213	38.7
064995	ACK-42	2-5/8 ODF	13.00	4.13	2.630 ± 0.003	1.50	23.00	1.44	680	50	375	71.7

Standard Product Offering

Cross Reference (Identical Lay-In)

Emerson	A-1 Components	Superior
ACK-4	MS-4	900M-4S
ACK-6	MS-6	900M-6S
ACK-8	MS-8	900M-8S
ACK-10	MS-10	900M-10S
ACK-12	MS-12	900M-12S
ACK-14	MS-14	900M-14S
ACK-18	MS-18	N/A
ACK-22	MS-22	N/A
ACK-26	MS-26	N/A
ACK-34	MS-34	N/A
ACK-42	MS-42	N/A

BV Series Refrigeration Ball Valves

R-410A

The BVE/BVS series welded refrigeration ball valves isolate suction, discharge, and liquid line pipework during maintenance shutdown periods.



Features

- Forged brass body
- Compact, lightweight, hermetic welded design
- Compatible with HCFC and HFC refrigerants/lubricants including R-410A and CO₂
- Full flow design*
- Bi-directional flow characteristics
- Valve stem cap retained by strap attached to main body
- Integrated access port available on all sizes
- Low operating friction design

Nomenclature example: BVE 1 1/8

BV	E	1/8
Ball Valve	Access Valve E = without S = with	Connection Size (in 1/8")

Specifications

- Body: Forged Brass
- Extended tubes: 100% Copper Connections
- Maximum working pressure: 650 psig
- Fluid temperature range: -40°F to 250°F (302°F short term)
- UL/CUL file number: SA 5312

Replacement Parts: Locking Seal Caps

BVE/BVS Valve Size (in.)	PCN	Quantity (per pack)
1/4 - 7/8	806770	10 pcs.
1 1/8 - 1 3/8	806771	10 pcs.
1 5/8 - 2 5/8	806772	10 pcs.

Standard Product Offering

Dimensional Data

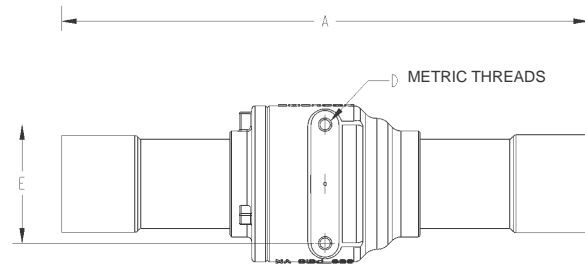
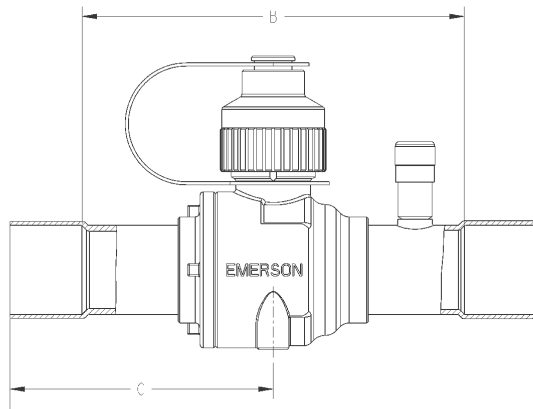

Selection & Ordering Information

Models Without Access Valve		Models With Access Valve		Connection Size (in.)	Dimensions					Port Size	Weight (lbs.)
Model	PCN	Model	PCN		A	B	C	D	E		
BVE 014	806730	BVS 014	806750	1/4 ODF	4.72	4.02	2.36	M3	0.59	Full Port	0.79
BVE 038	806732	BVS 038	806752	3/8 ODF	4.72	4.02	2.36		0.59	Full Port	0.79
BVE 012	806734	BVS 012	806754	1/2 ODF	5.00	4.21	2.50	M4	0.87	Full Port	0.79
BVE 058	806736	BVS 058	806756	5/8 ODF	5.00	3.98	2.50		0.87	Full Port	0.84
BVE 034	806737	BVS 034	806757	3/4 ODF	6.18	4.92	3.09		1.22	Full Port	1.45
BVE 078	806738	BVS 078	806758	7/8 ODF	6.18	4.65	3.09	M6	1.22	Full Port	1.45
BVE 118	806739	BVS 118	806759	1 1/8 ODF	6.65	4.84	3.33		1.50	Full Port	2.29
BVE 138	806741	BVS 138	806761	1 3/8 ODF	9.09	7.17	4.55	M6	1.89	Full Port	3.61
BVE 158	806742	BVS 158	806762	1 5/8 ODF	10.91	8.66	5.45		2.17	Full Port	5.35
BVE 218*	806744	BVS 218	806764	2 1/8 ODF	11.69	8.98	5.85		2.91	2" Port	10.48
BVE 258*	806745	BVS 258*	806765	2 5/8 ODF	11.69	8.74	5.85	M6	2.91	2" Port	12.20
BVE 318*	806746	BVS 318*	806766	1 3/8 ODF	11.69	8.39	5.85		2.91	2" Port	12.60

* 2" port

Standard Product Offering

Quick Select Guide

Hermetic Filter Driers			
Type	Filter Drier	Recommended Use	Function
Liquid	EK	CFC, HCFC, HFC	Premium Universal Replacement
Liquid	ADK	CFC, HCFC, HFC	High Acid and Water Removal
Liquid	BOK-HH	CFC, HCFC, HFC	Burnout Cleanup with Charcoal
Liquid	BFK	CFC, HCFC, HFC	Bi-Flow Heat Pump
Suction	SFD	CFC, HCFC, HFC	Suction Line Filter Drier
Suction	CSFD	CFC, HCFC, HFC	Compact Suction Line Filter Drier
Suction	ASD	CFC, HCFC, HFC	Premium Suction Line Filter Drier
Suction	ASK-HH	CFC, HCFC, HFC	Burnout Cleanup with Charcoal
Suction	ASF	CFC, HCFC, HFC	Filter Only
Take-Apart Filter Driers			
Type	Filter Drier	Liquid	Suction
Take-Apart	STAS	X	X
Take-Apart	ADKS	X	X
Take-Apart	BTAS		X
Replaceable Cores/Filters for Take- Apart Shells			
Type	Core/Filter	Recommended use	Function
Core	D-42/48	CFC, HCFC	High Acid Removal
Core	H-42/48/100	CFC, HCFC	High Acid and Water Removal
Core	W-42/48/100HH	CFC, HCFC, HFC	Burnout Cleanup w/Charcoal
Core	UK-48/100	CFC, HCFC, HFC	Premium Universal Replacement
Filter	F-48/100	CFC, HCFC, HFC	Filter Only
Core	RH-48	Reclaim Use Only	High Acid and Water Removal
Core	RW-48	Reclaim Use Only	Burnout Cleanup

Recommended System Tonnage

Take-Apart Liquid Line Filter Driers in Tons*

Description	Refrigeration, Low Temp. & Commercial Installations			Air Conditioning	
	R-12/R-134a	R-22	R-404A/R-502/R-507A	Field Replacement & Field Installations R-12/R-134a	R-22/R-407C/R-410A+
STAS 485T	8	10	8	8	10
STAS 487T	10	13	10	10	12 1/2
STAS 489T	10	15	10	10	15
STAS 4811T	13	20	13	13	20
STAS 967T	20	25	15	20	25
STAS 969T	25	30	20	25	30
STAS 9611T	30	35	25	30	35
STAS 9613T	35	40	30	35	40
STAS-9625S-V	40	45	35	40	45
STAS 1449T	30	40	30	30	40
STAS 14411T	40	50	35	40	50
STAS 14413T	45	55	40	45	55
STAS 14417T	60	50	45	50	60
STAS 19211T	50	70	45	50	70
STAS 19213T	60	80	55	60	80
STAS 19217T	65	85	60	65	85
ADKS 30013T	50	65	45	50	65
ADKS 30017T	60	80	50	60	80
ADKS 40017T	65	85	55	65	85
ADKS 40021T	75	100	65	75	100

* For kW, multiply tons by 3.5
 + Consult product catalog pages for R-410A suitability.

Recommended System Tonnage

Hermetic Liquid Line Filter Driers (EK, ADK, BFK, BOK)

(Recommended Capacities at 2 psi drop (See catalog page showing ARI data for capacity at 1 psi drop.)

Description	Refrigeration Low Temp. & Commercial Installations			Air Conditioning Field Replacement & Field Installations			
	R-12/R-134a	R-22	R-404A/R-502/R-507	R-12/R-134a	R-22/R-407C/R-410A		
032	1/2	1/2	1/2	1	1-1/2		
032S							
033							
033S							
052	3/4	3/4					
052S							
053	1-1/2	2	1-1/2	3	4		
053S							
082	1	1	3/4	1-1/2	2		
082S		2	2	1	3	4	
0825S			2	3		4	5
083	2	4		2	5	7-1/2	
083S		7-1/2	4				7-1/2
084				5	4	7-1/2	
084S		4	5				4
162	1-1/2			2	1	1-1/2	
162S		2	3				2
1625S	3			5	3	4	
163		7-1/2	10				5
163S				15		15	
164		4	5				4
164S	10			10	5	18	
165		7-1/2	15				5
165S	4			5	4	7-1/2	
303		4	5				4
303S	10			10	5	18	
304		7-1/2	15				5
304S	4			5	4	7-1/2	
305		7-1/2	10				5
305S	15			15	20	26	
307S		4	5				4
309S	7-1/2			7-1/2	7-1/2	12	
413		4	5				5
414	10			10	10	20	
414S		7-1/2	7-1/2				7-1/2
415	12			12	10	20	
415S		20	25				15
417S	10			12	10	20	
419S		22	30				20
757S	22			30	20	25	
759S		22	30				20
759S	22			30	20	25	

EK Liquid Line Filter Drier

R-410A

The EK Liquid Line filter drier is a premium compacted bead filter drier with a 20 micron outlet pad for maximum filtration. The EK is a premium universal replacement liquid line filter drier for CFC, HCFC and HFC refrigerants including R-12, R-134a, R-22, R-404A, R-407C, R-410A, R-500, R-502, and R-507.



Features

- Filtration first for more effective use of surface area of desiccant
- High moisture and acid removal capacity
- Solid copper connections
- Corrosion resistant epoxy powder paint finish
- Copeland® brand products approved for POE Oils
- Shock resistant steel shell construction

Specifications

- Desiccant blend - optimized for high water capacity and acid capacity
- Filtration: 20 microns
- Maximum working pressure: 680 psig
- UL/CUL file number: SA 3124

Nomenclature example: EK-083S

EK	08	3	S
Drier Series	Unit Size (in cu. in.)	Connection Size (in 1/8")	S = ODF connections (omit for SAE)

Dimensional Data

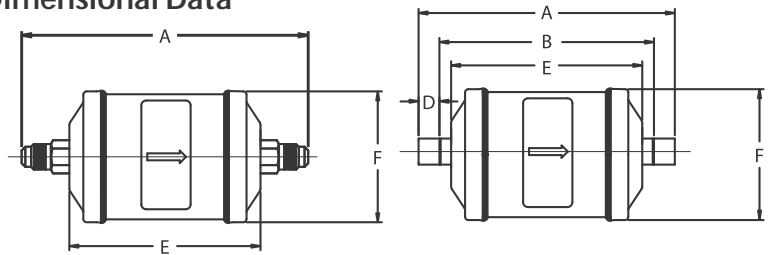

Ordering Information

PCN	Description	Dimensions (in)					Average Weight (lbs)
		A	B	D	E	F	
060009	EK 032	4.38					0.48
060012	EK 032S	3.83	2.71	0.56			
060011	EK 032FM	3.92			2.57	1.75	
060010	EK 032MF	3.92					
060013	EK 033	4.69					
060014	EK 033S	4.03	2.79	0.62			
047601	EK 052	4.83					1.04
057013	EK 052MF	4.37			3.02		
063978	EK 0525S	4.20	3.56	0.32	3.02	2.64	
047602	EK 052S	4.15	3.46	0.35			
047603	EK 053	5.14			3.02		
047604	EK 053S	4.48	3.24	0.62			
047605	EK 082	5.64					1.23
047606	EK 082S	4.96	4.27	0.35	3.83		
049551	EK 0825S	5.01	4.37	0.32			
056906	EK 083MF	5.70			3.83		
047607	EK 083	5.95					
047608	EK 083S	5.29	4.05	0.62	3.83		
047609	EK 084	6.17					1.49
047610	EK 084S	5.33	4.07	0.63			
047611	EK 162	6.58					
047612	EK 162S	5.90	5.21	0.35			
056045	EK 1625S	5.95	5.31	0.32			
047613	EK 163	6.89			4.77		
047614	EK 163S	6.24	5.43	0.40			
047615	EK 164	7.11					
047616	EK 164S	6.33	5.33	0.50			
047617	EK 165	7.57					
047618	EK 165S	6.55	5.30	0.63			
047619	EK 167S	7.13	5.63	0.75			
048210	EK 303	9.66					3.01
048211	EK 303S	9.01	8.21	0.40			
048212	EK 304	9.88					
048213	EK 304S	9.10	8.10	0.50			
048214	EK 305	10.34			7.54	3.14	
048215	EK 305S	9.32	8.07	0.63			
048216	EK 306S	9.73	8.48	0.63			
048217	EK 307S	9.90	8.40	0.75			
048218	EK 309S	10.26	8.45	0.90			
048219	EK 413	9.79					3.35
048220	EK 414	10.01					
048221	EK 414S	9.23	8.23	0.50			
048222	EK 415	10.47			7.67	3.64	
048223	EK 415S	9.45	8.20	0.63			
048224	EK 417S	10.03	8.53	0.75			
048225	EK 419S	10.39	8.58	0.91			
048228	EK 757S	15.25	14.02	0.61			6.14
048229	EK 759S	15.88	14.07	0.91	13.16		

EK Contractor's Choice Filter Drier

The EK Contractor's Choice filter drier is designed for foodservice and residential air conditioning applications.

Features

- Extended solid copper connections
- Dual access valves for faster and easier system diagnosis
- Incorporates all the internal features of the premium EK

Specifications

- Desiccant blend - optimized for high water capacity and acid capacity
- Filtration: 20 microns
- Maximum working pressure: 680 psig
- UL/CUL file number: SA 3124

R-410A



Ordering Information

PCN	Description
063908	EK 032S VV
065966	EK 052S VV
065963	EK 053S VV
065964	EK 083S VV
065965	EK 163S VV

Standard Product Offering

EK Cap Tube Filter Drier

The EK Cap Tube filter drier is designed for foodservice refrigeration systems.

Features

- Schrader valve on the inlet side acts as a maintenance and charging port
- Outlet is designed to accept capillary tubing without the need for crimping
- Extended solid copper 1/4 ODF connection inlet by cap tube
- Incorporates all the internal features of the premium EK

Specifications

- Desiccant blend - optimized for high water capacity and acid capacity
- Filtration: 20 microns
- Maximum working pressure: 680 psig
- UL/CUL file number: SA 3124

R-410A



Ordering Information

PCN	Description
063208	EK 032 SV CAP (3 cubic inch)
065846	EK 052 SV CAP (5 cubic inch)

Standard Product Offering

EK Filter Driers

Capacity Tables

Description	Connections Inlet/Outlet	Flow Capacity Tons @ 1 psi ΔP ^{1,4} (For kW, multiply tons by 3.5)						Water Capacity ² Drops of Water ³																					
		R-12		R-134a		R-22/R-410A		R-407C		R-404A/R-507		R-744		R-12		R-134a		R-22		R-407C		R-410A		R-404A/507		R-502		R-744	
		75°F	125°F	75°F	125°F	75°F	125°F	75°F	125°F	75°F	125°F	75°F	125°F	75°F	125°F	75°F	125°F	75°F	125°F	75°F	125°F	75°F	125°F	75°F	125°F	75°F	125°F	-10°F	25°F
EK 03 2 FM	1/4 Fem/1/4 Male SAE	1.6	2.0	2.2	2.1	1.4	2.8																						
EK 03 2 MF	1/4 Male/1/4 Fem SAE	1.6	2.0	2.2	2.1	1.4	2.8																						
EK 03 2	1/4 SAE	1.6	2.0	2.2	2.1	1.4	2.8																						
EK 03 2 S	1/4 ODF	2.2	2.7	2.9	2.9	2.0	3.7	47	41	40	37	40	33	33	25	21	19	38	37	42	37	30	34						
EK 032 SV	1/4 ODF	2.2	2.7	2.9	2.9	2.0	3.7																						
EK 03 3	3/8 SAE	2.5	3.0	3.3	3.2	2.2	4.3																						
EK 03 3 S	3/8 ODF	2.5	3.0	3.3	3.2	2.2	4.3																						
EK 05 2 FM	1/4 Fem/1/4 Male SAE	1.7	2.1	2.3	2.2	1.5	3.0																						
EK 05 2 MF	1/4 Male/1/4 Fem SAE	1.7	2.1	2.3	2.2	1.5	3.0																						
EK 05 2	1/4 SAE	1.7	2.1	2.3	2.2	1.5	3.0																						
EK 05 2 S	1/4 ODF	2.7	3.3	3.6	3.5	2.4	4.6	133	119	116	106	114	97	95	75	64	58	109	106	120	107	81	89						
EK 05 3 MF	3/8 Male/3/8 Fem SAE	2.9	3.5	3.8	3.7	2.5	4.9																						
EK 05 3	3/8 SAE	2.9	3.5	3.8	3.7	2.5	4.9																						
EK 05 3 S	3/8 ODF	3.6	4.4	4.8	4.7	3.2	6.2																						
EK 08 2 FM	1/4 Fem/1/4 Male SAE	1.9	2.3	2.5	2.4	1.7	3.2																						
EK 08 2 MF	1/4 Male/1/4 Fem SAE	1.9	2.3	2.5	2.4	1.7	3.2																						
EK 08 2	1/4 SAE	1.9	2.3	2.5	2.4	1.7	3.2																						
EK 08 2 S	1/4 ODF	2.5	3.1	3.4	3.3	2.2	4.4																						
EK 08 25 S	5/16 ODF	2.9	3.5	3.8	3.7	2.5	4.9																						
EK 08 3 MF	3/8 Male/3/8 Fem SAE	3.3	4.0	4.3	4.3	2.9	5.5	274	240	237	218	235	200	195	155	159	118	224	217	245	217	163	180						
EK 08 3	3/8 SAE	3.3	4.0	4.3	4.3	2.9	5.5																						
EK 08 3 S	3/8 ODF	3.7	4.5	4.9	4.8	3.3	6.3																						
EK 08 4	1/2 SAE	5.5	6.7	7.3	7.1	4.9	9.4																						
EK 08 4 S	1/2 ODF	5.8	7.1	7.7	7.5	5.1	9.9																						
EK 16 2 MF	1/4 Male/1/4 Fem SAE	1.9	2.3	2.5	2.4	1.7	3.2																						
EK 16 2	1/4 SAE	1.9	2.3	2.5	2.4	1.7	3.2																						
EK 16 2 S	1/4 ODF	2.5	3.1	3.4	3.3	2.2	4.4																						
EK 16 25 S	5/16 ODF	2.5	3.1	3.4	3.3	2.2	4.4																						
EK 16 3	3/8 SAE	3.2	3.9	4.2	4.1	2.8	5.4																						
EK 16 3 S	3/8 ODF	3.6	4.4	4.8	4.7	3.2	6.2	347	301	371	341	368	313	305	240	206	186	350	340	306	272	260	286						
EK 16 4	3/8 SAE	5	6.1	6.6	6.5	4.6	10.1																						
EK 16 4 S	1/2 ODF	7.0	8.5	9.2	9.0	6.2	11.9																						
EK 16 5	5/8 SAE	8.0	9.7	10.5	10.3	7.0	13.5																						
EK 16 5 S	5/8 ODF	8.3	10.1	10.9	10.7	7.3	14.1																						
EK 16 7 S	7/8 ODF	12.7	15.5	16.8	16.5	11.2	21.7																						
EK 30 3	3/8 SAE	3.5	4.3	4.7	4.6	3.1	6.1																						
EK 30 3 S	3/8 ODF	5.2	6.3	6.8	6.7	4.6	8.8																						
EK 30 4	1/2 SAE	6.6	8.1	8.8	8.6	5.9	11.4																						
EK 30 4 S	1/2 ODF	8.2	10.0	10.8	10.6	7.2	13.9																						
EK 30 5	5/8 SAE	8.7	10.6	11.5	11.3	7.7	14.8	601	526	664	611	657	561	548	434	515	355	627	608	536	477	458	504						
EK 30 6 S	3/4 ODF	12.1	14.8	16.0	15.7	10.7	20.6																						
EK 30 7 S	7/8 ODF	13.8	16.8	18.2	17.9	12.2	23.5																						
EK 30 9 S	1 1/8 ODF	16.1	19.6	21.2	20.8	14.2	27.3																						
EK 41 3	3/8 SAE	3.5	4.3	4.7	4.6	3.1	6.1																						
EK 41 4	1/2 SAE	8.5	10.4	11.3	11.1	7.5	14.6																						
EK 41 4 S	1/2 ODF	8.9	10.8	11.7	11.5	7.8	15.1																						
EK 41 5	5/8 SAE	9.8	12.0	13.0	12.8	8.7	16.8	1104	971	938	854	919	785	765	607	715	465	876	850	991	884	638	702						
EK 41 7 S	7/8 ODF	16.6	20.3	22.0	21.6	14.7	28.4																						
EK 41 9 S	1 1/8 ODF	22.7	27.7	30.0	29.4	20.1	38.7																						
EK 75 7 S	7/8 ODF	18.2	22.2	24.1	23.6	16.1	31.1	2368	2159	2159	2019	2159	1880	1810	1460	1460	1111	2019	2019	2229	2019	1578	1737						
EK 75 9 S	1 1/8 ODF	26.8	32.7	35.4	34.8	23.7	45.7																						

¹ All ratings in accordance with ARI Standard 710-04. 86°F liquid refrigerant temperature
5°F saturated vapor temperature
3.1 lbs./min./ton for R-134a
2.9 lbs./min./ton for R-22 and R-407C
4.0 lbs./min./ton for R-404A/507 and R-12
2.7 lbs./min./ton for R-410A

² Water Capacities are based on:
Equilibrium Point Dryness (EPD) of:
50 parts per million for R-134a, R404A/507,
R-410A and R-407C
60 parts per million for R-22
15 parts per million for R-12

³ 20 drops of water = 1 gram = 1 cc

⁴ For 2 PSI ΔP , Multiply values by 1.4

⁵ Since there is currently no ARI standard for R-744, values are based on 1 ton of refrigeration at 20°F liquid refrigerant temperature and -20°F saturated vapor temperature.

Liquid Refrigerant Holding Capacity-Ounces

Unit Size	R-12		R-134a		R-22		R-407C		R-410A		R-404A/R-507		R-502		R-744	
	75°F	125°F	75°F	125°F	75°F	125°F	75°F	125°F	75°F	125°F	75°F	125°F	75°F	125°F	20°F	-20°F
03	2.9	2.6	2.6	2.3	2.6	2.3	2.5	2.1	2.3	1.9	2.3	1.9	2.7	2.3	2.1	2.3
05	6.5	5.9	6.0	5.4	5.9	5.3	5.6	4.9	5.3	4.4	5.2	4.4	6.0	5.3	4.8	5.3
08	8.3	7.6	7.6	6.9	7.5	6.8	7.2	6.3	6.7	5.7	6.6	5.6	7.7	6.8	6.1	6.7
16	10.2	9.4	9.4	8.6	9.3	8.4	8.9	7.8	8.3	7.0	8.2	6.9	9.5	8.4	7.5	8.3
30	28.7	26.3	26.4	23.9	26.1	23.5	24.9	21.9	23.3	19.6	22.9	19.4	26.7	23.4	21.1	23.4
41	40.0	36.4	36.9	33.1	36.4	32.5	34.7	30.3	32.5	27.2	31.9	26.8	37.2	32.4	29.2	32.4
75	72.4	66.3	66.7	60.3	65.8	59.2	62.8	55.2	58.7	49.5	57.7	48.9	67.2	59.0	53.1	58.9

ADK Core Style Liquid Line Filter Drier

The ADK is a solid core liquid line filter drier good for use with CFC, HCFC, and HFC refrigerants.

Features

- Solid copper connections
- High moisture and acid removal capacity
- Corrosion resistant epoxy powder paint finish
- Copeland® products approved for POE oils

Specifications

- Desiccant Blend: optimized for high water capacity and acid capacity
- Filtration: 40 microns
- Maximum working pressure: 680 psig
- UL/CUL file number: SA 3124



Nomenclature example: ADK 083S

ADK	08	3	S
Series	Unit Size (in cu. in.)	Connection Size (in 1/8")	S = ODF connections (omit for SAE)

Dimensional Data

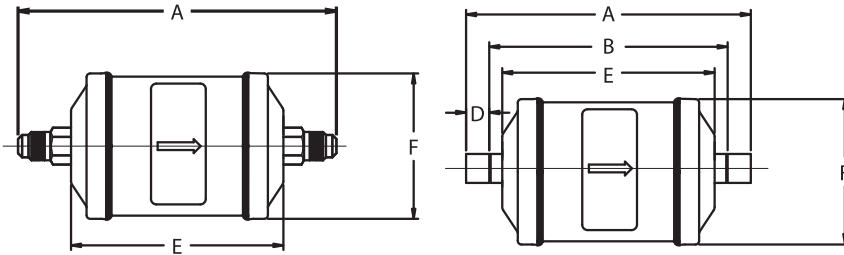

Ordering Information

PCN	Description	Connection Size	Dimensions (in)					Average Weight (lbs)
			A	B	D	E	F1	
059874	ADK-032	1/4 SAE	4.38					
052451	ADK-032S	1/4 ODF	3.83	2.71	0.56			
023157	ADK-033	3/8 SAE	4.69			2.57	1.75	0.51
053172	ADK-033S	3/8 ODF	4.03	2.79	0.62			
060125	ADK-052	1/4 SAE	4.84					
060126	ADK-052S	1/4 ODF	4.17	3.48	0.35			
060127	ADK-053	3/8 SAE	5.15			3.03	2.64	1.05
060128	ADK-053S	3/8 ODF	4.49	3.25	0.62			
060129	ADK-082	1/4 SAE	5.66					
060130	ADK-082S	1/4 ODF	4.99	4.29	0.35			
060131	ADK-083	3/8 SAE	5.97			3.85	2.64	1.25
060132	ADK-083S	3/8 ODF	5.30	4.07	0.62			
060133	ADK-084	1/2 SAE	6.19					
060134	ADK-084S	1/2 ODF	5.35	4.09	0.63			
059838	ADK-162S	1/4 ODF	5.35	4.66	0.35			
059820	ADK-162	1/4 SAE	6.59					
059839	ADK-163	3/8 SAE	6.90					
060795	ADK-163S	3/8 ODF	6.23	5	0.62			
059840	ADK-164	1/2 SAE	7.12			4.78	2.64	1.53
059841	ADK-164S	1/2 ODF	6.28	5.07	0.60			
059842	ADK-165	5/8 SAE	7.58					
059843	ADK-165S	5/8 ODF	6.55	5.09	0.73			
060172	ADK-303	3/8 SAE	9.66					
058507	ADK-303S	5/8 ODF	9.01	8.2	0.40			
060173	ADK-304	1/2 SAE	9.88					
060176	ADK-304S	1/2 ODF	9.10	8.1	0.50			
060174	ADK-305	5/8 SAE	10.34			7.54	3.14	3.11
060177	ADK-305S	5/8 ODF	9.32	8.07	0.63			
060178	ADK-307S	7/8 ODF	9.90	8.4	0.75			
060179	ADK-309S	1-1/8 ODF	10.26	8.448	0.90			
060182	ADK-413	3/8 SAE	9.82					
060183	ADK-414	1/2 SAE	10.04					
060185	ADK-414S	1/2 ODF	9.26	8.26	0.50			
060184	ADK-415	5/8 SAE	10.50			7.70	3.64	3.78
060186	ADK-415S	5/8 ODF	9.48	8.23	0.63			
060187	ADK-417S	7/8 ODF	10.62	8.56	0.75			
060188	ADK-419S	1-1/8 ODF	10.42	8.60	0.91			
060190	ADK-757S	7/8 ODF	15.55	14.05	0.75			
060191	ADK-759S	1-1/8 ODF	15.91	14.10	0.90	13.19	3.64	6.53

ADK Filter Driers

Capacity Tables

Description	Connection	Flow Capacity Tons @ 1 psi ΔP ^{1, 4} (For kW, multiply tons by 3.5)							Water Capacity ² Drops of Water ³																				
		R-12		R-134a		R-22		R-407C		R-404A/507		R-744		R-12		R-134a		R-22		R-407C		R-410A		R-404A/507		R-502		R-744	
		125°F	75°F	125°F	75°F	125°F	75°F	125°F	75°F	125°F	75°F	125°F	75°F	125°F	75°F	125°F	75°F	125°F	75°F	125°F	75°F	125°F	75°F	125°F	75°F	125°F	-10°F	25°F	
ADK 032	1/4 SAE	1.6	1.9	2.1	2.1	2.0	1.4	2.7	70	74	68	69	63	57	46	47	36	76	72	71	63	58	64	64	64	64	64	64	
ADK 032S	1/4 ODF	1.9	2.3	2.5	2.5	2.4	1.7	3.2																					
ADK 033	3/8 SAE	2.2	2.7	2.9	2.9	2.9	2.0	3.7																					
ADK 033S	3/8 ODF	2.5	3.0	3.3	3.3	3.2	2.2	4.3																					
ADK 052	1/4 SAE	1.6	2.0	2.2	2.2	2.1	1.4	2.8	185	195	180	180	130	150	120	125	95	200	190	185	165	144	169	169	169	169	169		
ADK 052S	1/4 ODF	2.4	2.9	3.1	3.1	3.1	2.1	4.0																					
ADK 053	3/8 SAE	3.0	3.7	4.0	4.0	3.9	2.7	5.2																					
ADK 053S	3/8 ODF	3.7	4.5	4.9	4.9	4.8	3.3	6.3																					
ADK 082	1/4 SAE	1.6	2.0	2.2	2.2	2.1	1.4	2.8	250	265	245	250	225	205	165	170	130	275	260	255	230	198	233	233	233	233	233		
ADK 082S	1/4 ODF	2.5	3.1	3.4	3.4	3.3	2.2	4.4																					
ADK 083	3/8 SAE	3.5	4.3	4.7	4.7	4.6	3.1	6.1																					
ADK 083S	3/8 ODF	3.4	4.2	4.6	4.6	4.5	3.0	5.9																					
ADK 084	1/2 SAE	5.5	6.7	7.3	7.3	7.1	4.9	9.4	365	390	360	265	330	300	240	250	190	400	380	375	335	328	386	386	386	386	386		
ADK 084S	1/2 ODF	5.7	7.0	7.6	7.6	7.4	5.1	9.8																					
ADK 162	1/4 SAE	1.6	2.0	2.2	2.2	2.1	1.4	2.8																					
ADK 163	1/4 SAE	3.6	4.4	4.8	4.8	4.7	3.2	6.2																					
ADK 163S	3/8 ODF	4.0	4.9	5.3	5.3	5.2	3.6	6.8	820	865	800	810	740	675	540	555	420	895	845	835	745	676	796	796	796	796	796		
ADK 164	1/2 SAE	6.8	8.3	9.0	9.0	8.8	6.0	11.6																					
ADK 164S	1/2 ODF	7.1	8.6	9.3	9.3	9.1	6.2	12.0																					
ADK 165	5/8 SAE	9.7	11.8	12.8	12.8	12.5	8.6	16.5																					
ADK 165S	5/8 ODF	10.7	13.1	14.2	14.2	13.9	9.5	18.3	1120	1210	1100	1140	1010	945	740	780	580	1260	1156	1170	1020	900	1060	1060	1060	1060	1060		
ADK 167S	7/8 ODF	13.1	16.0	17.3	17.3	17.0	11.8	22.3																					
ADK 303	3/8 SAE	3.9	4.7	5.1	5.1	5.0	3.4	6.6																					
ADK 304	1/2 SAE	7.1	8.6	9.3	9.3	9.1	6.2	12.0																					
ADK 304S	1/2 ODF	7.2	8.8	9.5	9.5	9.4	6.4	12.3	1985	2100	1940	1956	1800	1635	1310	1350	1030	2170	2050	2025	1800	1750	2060	2060	2060	2060	2060		
ADK 305	5/8 SAE	11.3	13.8	15.0	15.0	14.7	10.0	19.4																					
ADK 305S	4/8 ODF	11.9	14.5	15.7	15.7	15.4	10.5	20.3																					
ADK 306S	3/4 ODF	13.0	15.8	17.1	17.1	16.8	11.5	22.1																					
ADK 307S	7/8 ODF	14.3	17.4	18.9	18.9	18.5	12.6	24.4	1120	1210	1100	1140	1010	945	740	780	580	1260	1156	1170	1020	900	1060	1060	1060	1060	1060		
ADK 309S	1 1/8 ODF	20.4	24.9	27.0	27.0	26.5	18.0	34.8																					
ADK 413	3/8 SAE	3.9	4.7	5.1	5.1	5.0	3.4	6.6																					
ADK 414	1/2 SAE	8.0	9.8	10.6	10.6	10.4	7.1	13.7																					
ADK 414S	1/2 ODF	8.8	10.7	11.6	11.6	11.4	7.8	15.0	1120	1210	1100	1140	1010	945	740	780	580	1260	1156	1170	1020	900	1060	1060	1060	1060	1060		
ADK 415	5/8 SAE	12.8	15.6	16.9	16.9	16.6	11.3	21.8																					
ADK 415S	5/8 ODF	13.5	16.5	17.9	17.9	17.5	12.0	23.1																					
ADK 417S	7/8 ODF	16.6	20.3	22.0	22.0	21.7	14.7	28.4																					
ADK 419S	1 1/8 ODF	20.7	25.2	27.3	27.3	26.8	18.3	35.2	1985	2100	1940	1956	1800	1635	1310	1350	1030	2170	2050	2025	1800	1750	2060	2060	2060	2060	2060		
ADK 757S	7/8 ODF	28.0	34.2	37.1	37.1	36.3	24.8	47.9																					
ADK 759S	1 1/8 ODF	30.6	37.3	40.4	40.4	39.6	27.0	52.1																					

¹ All ratings in accordance with ARI Standard 710-04. 86°F liquid refrigerant temperature
 5°F saturated vapor temperature
 3.1 lbs./min./ton for R-134a
 2.9 lbs./min./ton for R-22 and R-407C
 4.0 lbs./min./ton for R-404A/507 and R-12
 2.7 lbs./min./ton for R-410A

² Water Capacities are based on:
 Equilibrium Point Dryness (EPD) of:
 50 parts per million for R-134a, R404-A/507,
 R-410A and R-407C
 60 parts per million for R-22
 15 parts per million for R-12

³ 20 drops of water = 1 gram = 1 cc

⁴ For 2 PSI ΔP, Multiply values by 1.4

⁵ Since there is currently no ARI standard for R-744, values are based on 1 ton of refrigeration at 20°F liquid refrigerant temperature and -20°F saturated vapor temperature.

Liquid Refrigerant Holding Capacity-Ounces

Unit Size	R-12		R-134a		R-22		R-407C		R-410A		R-404A/507		R-502		R-744	
	75°F	125°F	75°F	125°F	75°F	125°F	75°F	125°F	75°F	125°F	75°F	125°F	75°F	125°F	20°F	-20°F
03	2.4	2.2	2.2	2.0	2.2	2.0	2.1	1.9	2.0	1.7	1.9	1.7	2.7	2.3	1.8	2.0
05	5.9	6.0	5.5	5.5	5.4	5.4	5.2	5.0	4.8	4.5	4.7	4.5	6.0	5.3	4.9	5.4
08	8.0	7.4	7.4	6.7	7.3	6.6	7.0	6.2	6.5	5.5	6.4	5.5	7.7	6.8	5.9	6.5
16	14.5	12.5	13.4	11.4	13.2	11.2	12.6	10.4	11.7	9.4	11.6	9.3	9.5	8.4	10.1	11.2
30	21.8	19.9	20.1	18.1	19.8	17.8	18.9	16.6	17.4	14.9	17.4	14.7	26.7	23.4	16.0	17.7
41	29.3	26.8	26.9	24.4	26.6	23.9	25.4	22.3	23.7	20.0	23.3	19.7	37.2	32.4	21.4	23.8
75	52.8	48.3	48.6	43.9	48.0	43.1	45.8	40.2	42.8	36.0	42.1	35.6	67.2	59.0	38.7	42.9

BFK Liquid Line Bi-Directional Filter Drier

R-410A

The BFK is a solid core, bi-directional, liquid line filter drier for heat pump applications for use with CFC, HCFC, and HFC refrigerants.

Features

- Available 5 to 30 cu. in. size
- Internal check valves allow flow and filtration in either direction, eliminates need for external check valves
- High moisture and acid removal capacity
- Corrosion resistant epoxy powder paint finish
- Copeland® brand products approved for POE oils



Specifications

- Desiccant Blend: optimized for high water capacity and acid capacity
- Filtration: 40 microns
- Maximum working pressure: 680 psig
- UL/CUL file number: SA 3124

Nomenclature example: BFK 165S

BFK	16	5	S
Series	Unit Size (in cu. in.)	Connection Size (in 1/8")	S = ODF connections (omit for SAE)

Dimensional Data

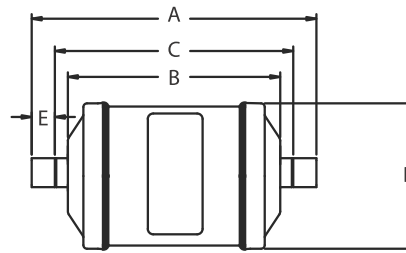
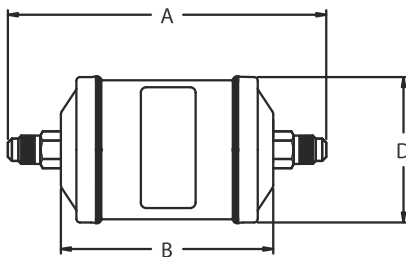

Ordering Information

PCN	Description	Connection	Dimension (in)					Average Weight (lbs)
			A	B	C	D	E	
062300	BFK-052	1/4 SAE	4.84	3.03	3.47	2.64	0.35	0.99
062425	BFK-052S	1/4 ODF	4.16					
062254	BFK-053	3/8 SAE	5.15					
062255	BFK-053S	3/8 ODF	4.49	3.84	4.38	0.32		
043321	BFK-083	3/8 SAE	5.96					
043323	BFK-083S	3/8 ODF	5.31					
043325	BFK-084	1/2 SAE	6.184					
043327	BFK-084S	1/2 ODF	5.40	4.40	0.50	0.63		
043728	BFK085	5/8 SAE	6.64					
043730	BFK-085S	5/8 ODF	5.62					
043330	BFK-163	3/8 SAE	6.824	4.70	5.37	0.40	2.08	
043333	BFK-163S	3/8 ODF	6.17					
043335	BFK-164	1/2 SAE	7.04					
043337	BFK-164S	1/2 ODF	6.26					
043732	BFK-165	5/8 SAE	7.50					
043734	BFK-165S	5/8 ODF	6.48	5.23	0.63	0.75		
058589	BFK-167S	7/8 ODF	7.06					
063076	BFK303	3/8 SAE	9.674	7.55	7.77	3.14	0.62	
063077	BFK-303S	3/8 ODF	9.01					
063078	BFK-304	1/2 SAE	9.89					
063079	BFK-304S	1/2 ODF	9.05					
063080	BFK-305	5/8 SAE	10.35					
063081	BFK-305S	5/8 ODF	9.32					
063082	BFK-306	3/4 SAE	10.67					
063083	BFK-306S	3/4 ODF	9.74					
063084	BFK-307S	7/8 ODF	9.91					
063451	BFK-309S	1 1/8 ODF	10.27					
								0.35

BFK Liquid Line Bi-Directional Filter Drier

Description	Connection	Flow Capacity Tons @ 1 psi ΔP ^{1,4} (For kW, multiply tons by 3.5)				Water Capacity ² Drops Of Water ³							
		R-22		R-410A		R-407C		R-410A		R-744			
		75°F	125°F	75°F	125°F	75°F	125°F	75°F	125°F	-10°F	25°F		
BFK-05 2	1/4 SAE	1.6	1.6	1.6	2.1	73	66	58	42	39	35	81	89
BFK-05 2S	1/4 ODF	2.2	2.2	2.2	2.8								
BFK-05 3	3/8 SAE	3.5	3.5	3.4	4.5								
BFK-05 3S	3/8 ODF	4.0	4.0	3.9	5.2								
BFK-08 3	3/8 SAE	4.5	4.5	4.4	5.8	159	144	106	79	85	75	136	150
BFK-08 3S	3/8 ODF	5.1	5.1	5.0	6.6								
BFK-08 4	1/2 SAE	6.4	6.4	6.3	8.3								
BFK-08 4S	1/2 ODF	6.7	6.7	6.6	8.6								
BFK-08 5	5/8 SAE	7.2	7.2	7.0	9.3								
BFK-08 5S	5/8 ODF	8.1	8.1	7.9	10.4								
BFK-16 3	3/8 SAE	4.6	4.6	4.5	5.9	323	294	237	179	178	160	221	260
BFK-16 3S	3/8 ODF	5.2	5.2	5.1	6.7								
BFK-16 4	1/2 SAE	7.7	7.7	7.6	9.9								
BFK-16 4S	1/2 ODF	8.1	8.1	7.9	10.4								
BFK-16 5	5/8 SAE	8.3	8.3	8.1	10.7								
BFK-16 5S	5/8 ODF	8.7	8.7	8.5	11.2								
BFK-30 3S	3/8 ODF	5.8	5.8	5.7	7.5	585	532	452	345	415	293	453	533
BFK-30 4	1/2 SAE	7.6	7.6	7.5	9.8								
BFK-30 4S	1/2 ODF	9.7	9.7	9.5	12.5								
BFK-30 5	5/8 SAE	10.3	10.3	10.1	13.3								
BFK-30 5S	5/8 ODF	14.2	14.2	13.9	18.3								
BFK-30 6S	3/4 ODF	16.0	16.0	15.7	20.6								
BFK-30 7S	7/8 ODF	16.7	16.7	16.4	21.5								
BFK-30 9S	1 1/8 ODF	18.0	18.0	17.5	23.2								

¹ All ratings in accordance with ARI Standard 710-04. 86°F liquid refrigerant temperature
5°F saturated vapor temperature
3.1 lbs./min./ton for R-134a
2.9 lbs./min./ton for R-22 and R-407C
4.0 lbs./min./ton for R-404A/507 and R-12
2.7 lbs./min./ton for R-410A

² Water Capacities are based on:
Equilibrium Point Dryness (EPD) of:
50 parts per million for R-134a, R404-A/507,
R-410A and R-407C
60 parts per million for R-22
15 parts per million for R-12

³ 20 drops of water = 1 gram = 1 cc

⁴ For 2 PSI ΔP, Multiply values by 1.4

⁵ Since there is currently no ARI standard for R-744, values are based on 1 ton of refrigeration at 20°F liquid refrigerant temperature and -20°F saturated vapor temperature.

Liquid Refrigerant Holding Capacity-Ounces

Unit Size	R-22		R-407C		R-410A		R-744	
	75°F	125°F	75°F	125°F	75°F	125°F	20°F	-20°F
05	4.6	4.2	4.4	3.9	4.1	3.5	3.7	4.1
08	7.7	6.9	7.3	6.4	6.9	5.8	6.2	6.9
16	14.2	12.7	13.5	11.8	12.6	10.6	11.4	12.7
30	21.0	18.7	20.0	17.4	19.6	16.5	16.8	18.7

BOK-HH Liquid Line Burnout Filter Drier

The BOK-HH is a liquid line filter drier for burnout clean-up and wax removal. The BOK-HH incorporates an activated carbon blended solid core for the effective clean-up of systems following a severe burnout.

Features

- Designed for maximum effectiveness in the clean-up of systems following a severe burnout
- Corrosion resistant epoxy powder paint finish
- Activated carbon blend for soluble contaminant and wax removal
- Solid copper connections
- R-410A compatible

Nomenclature example: BOK 305S-HH

BOK	30	5	S	HH
Series	Unit Size (in cu. in.)	Connection Size (in 1/8")	S = ODF connections (omit for SAE)	Activated carbon Blend

Dimensional Data

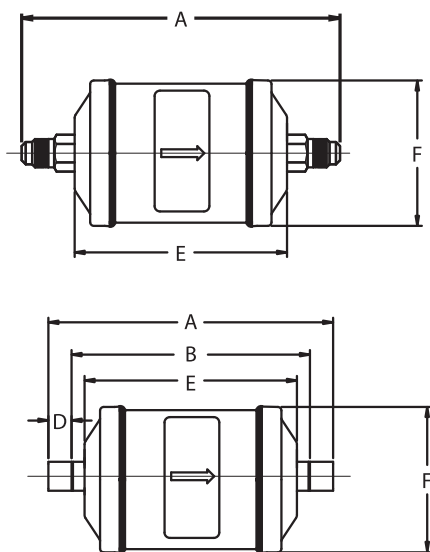

Specifications

- Filtration: 40 microns
- Maximum working pressure: 680 psig
- UL/CUL file number: SA 3124

Ordering Information

PCN	Description	Connection Size	Dimensions (in)					Weight (lbs)
			A	B	D	E	F ¹	
060223	BOK-082-HH	1/4 SAE	5.63	--	--	3.94	2.94	1.00
064591	BOK-082SH	1/4 ODF	5.00	4.31	0.38	3.81	2.63	
060224	BOK-083-HH	3/8 SAE	5.94	--	--	3.94	2.94	
057995	BOK-083SH	3/8 ODF	5.38	4.06	0.63	3.81	2.63	
060240	BOK-162-HH	1/4 SAE	6.44	--	--	3.94	2.94	
064592	BOK-162S-HH	1/4 ODF	6.03	5.29	0.38	4.63	3.13	
060241	BOK-163-HH	3/8 SAE	6.75	--	--	3.94	2.94	2.00
060242	BOK-163S-HH	3/8 ODF	6.13	5.25	0.94	4.63	2.88	
060228	BOK-164-HH	1/2 SAE	6.94	--	--			
060229	BOK-164S-HH	1/2 ODF	6.19	5.16	0.50	7.50	3.06	3.75
060230	BOK-165-HH	5/8 SAE	7.44	--	--			
060231	BOK-165S-HH	5/8 ODF	6.38	5.13	0.63			
060232	BOK-303-HH	3/8 SAE	9.63	--	--			
060233	BOK-304-HH	1/2 SAE	9.88	--	--			
060234	BOK-304S-HH	1/2 ODF	9.13	8.13	0.50			
060235	BOK-305-HH	5/8 SAE	10.31	--	--	763	3.69	4.75
060236	BOK-305S-HH	5/8 ODF	9.31	8.06	0.63			
060237	BOK-414-HH	1/2 SAE	10.00	--	--			
060238	BOK-415-HH	5/8 SAE	9.25	8.25	0.50	763	3.69	4.75
060239	BOK-417S-HH	7/8 ODF	10.44	--	--			
064593	BOK-415S-HH	5/8 ODF	9.25	8.25	0.50			

¹ Does not include weld bead

Standard Product Offering

BOK-HH Liquid Line Burnout Filter Drier

Description	Connections	Flow Capacity ^{1,4} Tons @ 1 psi ΔP (For kW, multiply tons by 3.5)								Water Capacity ² Drops Of Water ³														
		R-12		R-134a		R-22		R-407C		R-410A		R-404A/R-507		R-502		R-744								
		75°F	125°F	75°F	125°F	75°F	125°F	75°F	125°F	75°F	125°F	75°F	125°F	75°F	125°F	-10°F	25°F							
BOK 08 2-HH	1/4 SAE	1.2	1.5	1.6	1.6	1.6	1.1	2.1	180	118	88	71	78	59	74	45	66	38	93	71	109	79	51	63
BOK 082SH	1/4 ODF	-	3.1	3.4	3.4	3.3	2.2	4.4	-	-														
BOK 08 3-HH	3/8 SAE	3.2	3.9	4.2	4.2	4.1	2.8	5.4	180	118														
BOK 083SH	3/8 ODF	-	4.2	4.6	4.6	4.5	3.0	5.9	-	-														
BOK 16 2-HH	1/4 SAE	1.2	1.5	1.6	1.6	1.6	1.1	2.1	209	143	171	141	153	117	91	56	77	41	182	141	135	100	93	113
BOK 16 3-HH	3/8 SAE	3.6	4.3	4.7	4.7	4.6	3.1	6.1																
BOK 16 3S-HH	3/8 ODF	4.8	5.8	6.3	6.3	6.2	4.2	8.1																
BOK 16 4-HH	1/2 SAE	7.0	8.6	9.3	9.3	9.1	6.2	12.0																
BOK 16 4S-HH	1/2 ODF	8.4	10.2	11.1	11.1	10.9	7.4	14.3																
BOK 16 5-HH	5/8 SAE	10.5	12.8	13.9	13.9	13.6	9.3	17.9																
BOK 16 5S-HH	5/8 ODF	10.5	12.8	13.9	13.9	13.6	9.3	17.9																
BOK 30 3-HH	3/8 SAE	3.6	4.3	4.7	4.7	4.6	3.1	6.1																
BOK 30 4-HH	1/2 SAE	8.1	9.9	10.7	10.7	10.5	7.2	13.8																
BOK 30 4S-HH	1/2 ODF	8.9	10.8	11.7	11.7	11.5	7.8	15.1																
BOK 30 5-HH	5/8 SAE	11.1	13.5	14.6	14.6	14.3	9.8	18.8																
BOK 30 5S-HH	5/8 ODF	12.0	14.6	15.8	15.8	15.5	10.6	20.4																
BOK 41 4-HH	1/2 SAE	8.4	10.2	11.1	11.1	10.9	7.4	14.3	623	410	427	344	379	282	256	155	220	125	454	342	380	274	249	305
BOK 41 5-HH	5/8 SAE	13.4	16.3	17.7	17.7	17.4	11.8	22.8																
BOK 41 5S-HH	5/8 ODF	13.4	16.3	17.7	17.7	21.1	14.4	22.8																
BOK 41 7S-HH	7/8 ODF	16.3	19.8	21.5	21.5	21.1	14.4	27.7																

¹ All ratings in accordance with ARI Standard 710-04. 86°F liquid refrigerant temperature
 5°F saturated vapor temperature
 3.1 lbs./min./ton for R-134a
 2.9 lbs./min./ton for R-22 and R-407C
 4.0 lbs./min./ton for R-404A/507 and R-12
 2.7 lbs./min./ton for R-410A

² Water Capacities are based on:
 Equilibrium Point Dryness (EPD) of:
 50 parts per million for R-134a, R404-A/507,
 R-410A and R-407C
 60 parts per million for R-22
 15 parts per million for R-12

³ 20 drops of water = 1 gram = 1 cc

⁴ For 2 PSI ΔP, Multiply values by 1.4

⁵ Since there is currently no ARI standard for R-744,
 values are based on 1 ton of refrigeration at 20°F liquid refrigerant temperature and -20°F saturated vapor temperature.

Liquid Refrigerant Holding Capacity - Ounces

Unit Size	R-12		R-134a		R-22		R-407C		R-410A		R-404A/507		R-502		R-744	
	75°F	125°F	75°F	125°F	75°F	125°F	75°F	125°F	75°F	125°F	75°F	125°F	75°F	125°F	20°F	-20°F
08	7.3	6.6	6.7	6.0	6.6	5.9	6.3	5.5	5.9	4.9	5.8	4.9	6.7	5.9	5.3	5.9
16	13.9	12.7	12.8	11.5	12.6	11.3	12.0	10.5	11.2	9.4	11.1	9.3	12.9	11.3	10.1	11.3
30	21.8	19.9	20.1	18.1	19.8	17.8	18.9	16.6	11.7	14.9	17.4	14.7	20.2	17.7	16.0	17.7
41	29.3	26.8	26.9	24.4	26.6	23.9	25.4	22.3	23.7	20.0	23.3	19.7	27.2	23.8	21.4	23.8

ALF Liquid Filter

The ALF is a liquid line refrigerant filter for recovery, recycle and reclaim usage. The ALF is also used for protecting solenoid and expansion valve parts from debris.

Features

- Filtering media that maximizes removal of finer particles
- Corrosion resistant epoxy powder paint finish

Nomenclature example: ALF 033S

ALF	03	3	S
Series	Unit Size	Connection Size Inlet (in 1/8")	Connection Style S = ODF Omit for SAE

Dimensional Data

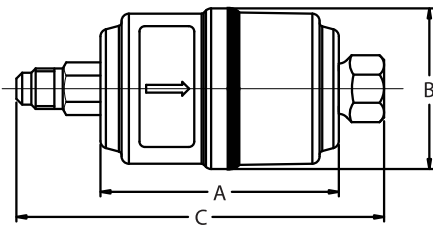

Recovery, Recycle and Reclaim Refrigerant Flow Capacity (lbs./min. liquid)		
R-134A	R-22/R-410A	R-404A/R-507
7.6	8.0	8.0



Specifications

- Filtration: 40 microns
- Maximum working pressure: 680 psig
- UL/CUL file number: SA 3124

Ordering Information

PCN	Description	Dimensions (in)			
		Connection Size Inlet/Outlet	A	B ¹	C
058500	ALF-032	1/4 SAE	2.56	1.63	4.38
056618	ALF-032S	1/4 ODF			3.88
057193	ALF-032MF	1/4 SAE Male In 1/4 SAE Female Out	3.00	2.63	4.00
057140	ALF-033S	3/8 ODF			4.13
056645	ALF-034S	1/2 ODF			4.88
064777	ALF-052	1/4 SAE			

¹ Does not include weld bead

Standard Product Offering

Spun Copper Liquid Line Filter Drier

The CU series is a high capacity spun copper solid core Filter Drier ideal for superior corrosion resistance in ocean going vessels and coastal applications.



Features

- All copper construction for extreme corrosion resistance
- 100% molecular sieve solid core drier
- For use with CFC, HCFC and HFC refrigerants

Nomenclature example: CU 163S

CU	16	3	S
Series	Unit Size	Connection Size (in 1/8")	ODF

Specifications

- Maximum working pressure: 500 psig
- Filtration: 40 microns
- UL/CUL file number: SA 7175

Ordering Information and Capacity Tables

PCN	Description	Connection	Flow Capacity Tons @ 1 psi ΔP ¹⁴ (For kW, multiply tons by 3.5)					Water Capacity ² Drops of Water ³											
								R-12		R-134a		R-22		R-407C		R-404A/R-507		R-502	
			R-12	R-134a	R-22	R-407C	R-404A/R-507	75°F	125°F	75°F	125°F	75°F	125°F	75°F	125°F	75°F	125°F		
064388	CU 03 2 S	1/4 ODF	1.4	1.7	1.8	1.8	1.2	96	87	93	87	87	81	72	57	96	93	90	81
064389	CU 03 3 S	3/8 ODF	2.1	2.6	2.8	2.7	1.9	112	101	108	101	101	93	82	63	112	108	104	93
064390	CU 05 2 S	1/4 ODF	1.5	1.8	2.0	2.0	1.3	212	191	205	191	191	177	156	122	212	205	198	177
064391	CU 05 3 S	3/8 ODF	2.1	2.6	2.8	2.7	1.9	287	257	277	257	257	237	207	158	287	277	267	237
064392	CU 08 2 S	1/4 ODF	1.6	1.9	2.1	2.1	1.4												
064393	CU 08 3 S	3/8 ODF	2.9	3.5	3.8	3.7	2.5												
064394	CU 08 4 S	1/2 ODF	3.5	4.2	4.6	4.5	3.1												
064395	CU 16 3 S	3/8 ODF	3.3	4.0	4.3	4.2	2.9												
064396	CU 16 4 S	1/2 ODF	3.9	4.7	5.1	5.0	3.4												
064397	CU 16 5 S	5/8 ODF	4.4	5.4	5.8	5.7	3.9												

Standard Product Offering

¹ All ratings in accordance with ARI Standard 710-04. 86°F liquid refrigerant temperature
5°F saturated vapor temperature
3.1 lbs./min./ton for R-134a
2.9 lbs./min./ton for R-22 and R-407C
4.0 lbs./min./ton for R-404A/507 and R-12
2.7 lbs./min./ton for R-410A

² Water Capacities are based on:
Equilibrium Point Dryness (EPD) of:
50 parts per million for R-134a, R404-A/507,
R-410A and R-407C
60 parts per million for R-22
15 parts per million for R-12

³ 20 drops of water = 1 gram = 1 cc

⁴ For 2 PSI ΔP, Multiply values by 1.4

Dimensional Data (in)

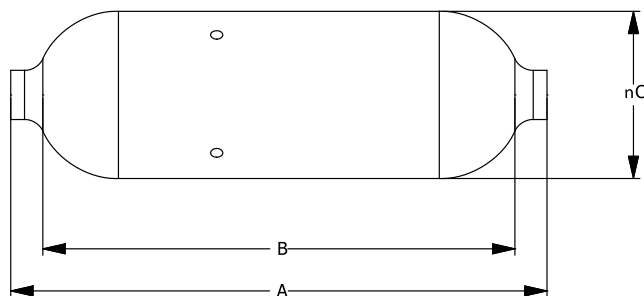

Description	Overall Length (A)	Lay-In Dimension (B)	Diameter
CU 03	3.94	3.25	1.63
CU 05	5.19	4.50	1.63
CU 08	6.06	5.38	2.00
CU 16	6.63	6.00	2.00

Spun Copper Liquid Line Service Filter Drier

Recommended for use in original equipment or replacement residential, air-conditioning or refrigeration equipment.

Features

- All copper construction for extreme corrosion resistance
- 100% molecular sieve solid core drier
- For use with CFC, HCFC and HFC refrigerants

Specifications

- Maximum working pressure: 500 psig
- Filtration: 100 microns
- UL/CUL file number: SA 7175



Ordering Information and Capacity Tables

PCN	Description	Parker Equivalent	Connections		Flow Capacity Tons @ 1 psi ΔP ¹⁴ (For kW, multiply tons by 3.5)			Water Capacity ² Drops of Water ³					
								R-134a		R-22		R-404A/R-507	
			Inlet	Outlet	R-12/R-134a	R-22/R-410A	R-404A/R-507	75°F	125°F	75°F	125°F	75°F	125°F
064023	CU-80	MMS-80	1/4 ODF	1/4 ODF	.33	.5	.33	25	23	25	22	23	23
064026	CU-619	620-SP	1/4 ODF	Cap	.5	.5	1.5	25	23	25	22	23	23
064027	CU-620	620	5/16 ODF	Cap	1.0	2.0	1.0	50	46	50	44	46	46
064119	CU-621	621	5/16 ODF	Cap	.5	.5	1.5	50	46	50	44	46	46
064024	CU-200	MMS-200	5/16 ODF, 3/8 ODF	5/16 ODF, 3/8 ODF	.75	1.0	.75	50	46	50	44	46	46
064025	CU-319	319	5/16 ODF	Cap	1.0	2.0	1.0	75	66	75	66	69	69

Standard Product Offering

¹ All ratings in accordance with ARI Standard 710-04. 86°F liquid refrigerant temperature
5°F saturated vapor temperature
3.1 lbs./min./ton for R-134a
2.9 lbs./min./ton for R-22 and R-407C
4.0 lbs./min./ton for R-404A/507 and R-12
2.7 lbs./min./ton for R-410A

² Water Capacities are based on:
Equilibrium Point Dryness (EPD) of:
50 parts per million for R-134a, R404-A/507,
R-410A and R-407C
60 parts per million for R-22
15 parts per million for R-12

³ 20 drops of water = 1 gram = 1 cc

⁴ For 2 PSI ΔP, Multiply values by 1.4

Dimensional Data (in)

Description	Length	Diameter
CU-80	7 3/8	3/4
CU-619	8 7/8	3/4
CU-620	9 1/2	1
CU-621	9	1
CU-200	10 1/2	1
CU-319	9 3/4	1 3/16

STAS Steel Liquid and Suction Line Filter Drier

R-410A

The STAS is a replaceable core filter drier for CFC, HCFC, and HFC refrigerants for use in large commercial air conditioning and refrigeration systems.

Features

- Slotted cover/unique internal hardware for hassle-free installation
- Full flow fittings for low pressure drop
- Corrosion resistant epoxy powder paint finish
- Sturdy steel shells for long life
- Solid copper connections
- 100 mesh outlet screen



Nomenclature example: STAS 489T

STAS	48	9	T
Steel Take-Apart Series	Unit Size (in cu. in.)	Connection Size (in 1/8")	System Service T = Liquid Line Service SV = Suction Line Service

Specifications

- Filtration (with core): 40 microns
- Maximum working pressure: SV version = 500 psig
T version = 680 psig
- UL/CUL file number: SA7175

STAS Models are shipped without filter or filter drier cores.
See filter or filter drier cores for availability.

Dimensional Data

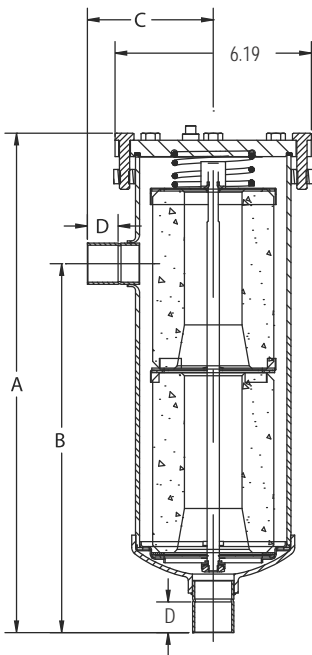

Ordering Information

PCN	Description	Connection Size	Number Of 48 in ³ Cores	Desiccant Volume (Cu. In.)	Dimensions (in)					
					A	B	C	D		
053001	STAS-485T	5/8 ODF	1	48	9.94	6.00	3.78	0.63		
053003	STAS-487T	7/8 ODF			9.69	6.25	3.75	0.78		
053005	STAS-489T	1 1/8 ODF			9.75	6.31	3.84	0.94		
053007	STAS-4811T	1 3/8 ODF			9.84	6.44	3.97	0.94		
053043	STAS-4813S-V ¹	1 5/8 ODF			9.88	6.02	4.03	1.13		
053044	STAS-4817S-V ¹	2 1/8 ODF			10.06	6.56	4.56	1.34		
053045	STAS-4821S-V ¹	2 5/8 ODF			10.44	7.03	4.75	1.04		
053375	STAS-4813T	1 5/8 ODF			9.88	6.50	4.03	1.13		
053938	STAS-4811SV	1 3/8 ODF			9.84	6.44	3.97	0.94		
053010	STAS-967T	7/8 ODF			2	96	15.19	11.72	3.75	0.78
053012	STAS-969T	1 1/8 ODF	15.22	11.78			3.84	0.94		
053014	STAS-9611T	1 3/8 ODF	15.31	11.91			3.97	1.03		
053017	STAS-9613T	1 5/8 ODF	15.38	11.97			4.03	1.13		
053018	STAS-9617T	2 1/8 ODF	15.56	12.03			4.56	1.34		
053047	STAS-9617S-V ¹	2 1/8 ODF	15.56	12.03			4.56	1.34		
053048	STAS-9621S-V ¹	2 5/8 ODF	15.94	12.50			4.75	1.50		
059739	STAS-9625 SV ¹	3 1/8 ODF	16.54	12.63			5.44	1.66		
053020	STAS-1449T	1 1/8 ODF	21.25	17.38			3.84	0.94		
053022	STAS-14411T	1 3/8 ODF	21.34	17.53			3.97	1.03		
053024	STAS-14413T	1 5/8 ODF	3	144	21.38	17.59	4.03	1.13		
053025	STAS-14417T	2 1/8 ODF			21.56	17.63	4.56	1.34		
053028	STAS-19211T	1 3/8 ODF			4	192	26.91	23.00	3.97	1.03
053030	STAS-19213T	1 5/8 ODF					26.94	23.17	4.03	1.13
053031	STAS-19217T	2 1/8 ODF	27.13	23.13			4.56	1.34		
056213	STAS-1927/5T	7/8 X 5/8	26.50	6.00			3.69	0.78/0.63		

¹SV style include stainless steel bolts and access valve.

NOTE: "T" style can be used for suction by removing pipe plug and installing X-11562-2.

Standard Product Offering

STAS Steel Liquid and Suction Line Filter Drier

Description	Connections	Liquid Flow Capacity Tons @ 1 psi ΔP ^{1,2,3}						
		R-12	R-134a	R-22	R-407C	R-404A/507	R-502	R-410A
STAS-485T	5/8 ODF	16	21	22	21	15	14	22
STAS-487T	7/8 ODF	29	38	41	39	27	25	41
STAS-489T	1 1/8 ODF	42	53	58	56	38	36	58
STAS-4811T	1 3/8 ODF	48	75	81	78	53	41	81
STAS-4813T	1 5/8 ODF	67	81	89	85	58	58	89
STAS-967T	7/8 ODF	33	42	45	43	30	27	45
STAS-969T	1 1/8 ODF	49	65	71	68	47	42	71
STAS-9611T	1 3/8 ODF	62	80	87	83	57	54	87
STAS-9613T	1 5/8 ODF	67	92	100	95	65	58	100
STAS-1449T	1 1/8 ODF	48	66	72	69	47	41	72
STAS-14411T	1 3/8 ODF	69	92	100	96	65	60	100
STAS-14413T	1 5/8 ODF	77	93	101	97	66	66	101
STAS-14417T	2 1/8 ODF	88	110	120	115	78	76	120
STAS-19211T	1 3/8 ODF	75	94	102	98	67	64	102
STAS-19213T	1 5/8 ODF	81	103	113	108	74	69	113
STAS-19217T	2 1/8 ODF	91	113	123	117	80	78	123

¹ All ratings in accordance with ARI Standard 710-04. 86°F liquid refrigerant temperature
 • 5°F saturated vapor temperature
 • 3.1 lbs./min./ton for R-134a
 • 2.9 lbs./min./ton for R-22 and R-407C
 • 4.0 lbs./min./ton for R-404A/507 and R-12
² For 2 PSI ΔP, Multiply values by 1.4
³ For kW, multiply by 3.5

Replacement Parts For STAS

Flange Cover Assembly	Description	PCN
All STAS Driers - Include Flange Cover, Compression Spring, Pipe Plug, and Grade 5 Bolts	X12176-3	054046
Shell Strainer Assembly		
STAS-48	X27458-1	060274
STAS-96	X27458-2	060275
STAS-144	X27458-3	060276
STAS-192	X27458-4	060277
Miscellaneous Parts		
Cover Bolts (Stainless Steel - suction line service)	X25787-7	053121
Access Valve (V Option)	X11562-2	037409
Gasket Set (Includes cover gasket)	X11983-1	027453
Handle	26446-1	053812
Inlet Retainer	26477-1	053813
Spring	26439-1	060258
Mounting Bracket	X28747-1	061715

Standard Product Offering

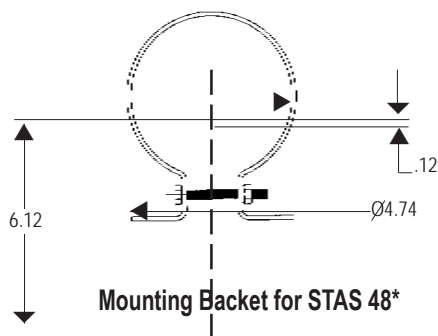

*More than one mounting bracket may be required for shell sizes 96 and above.

Exploded View

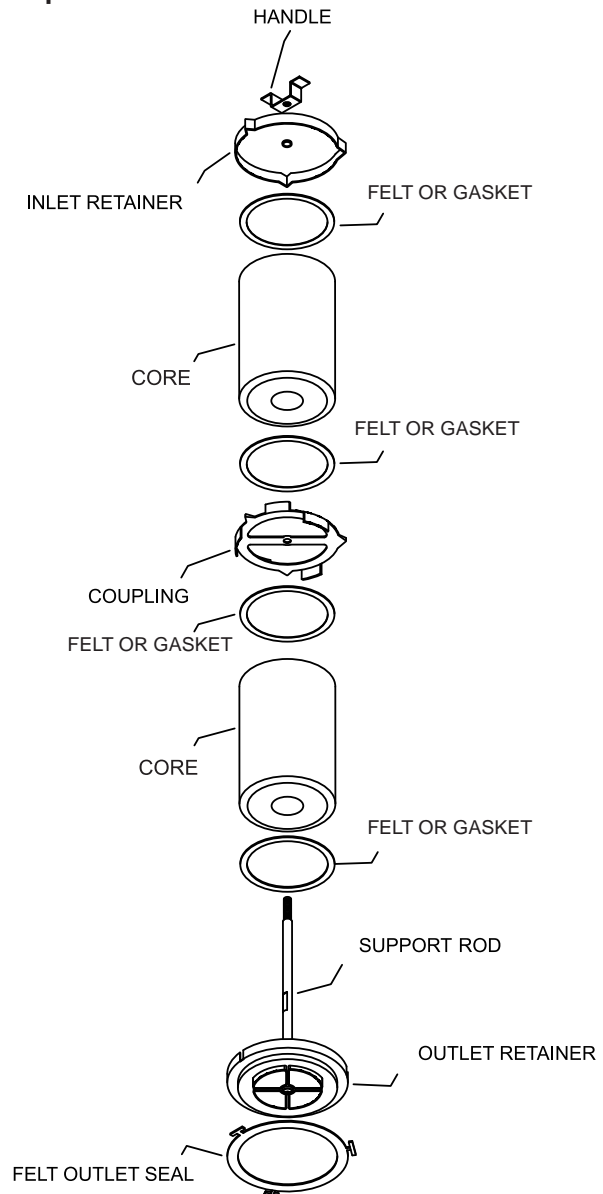

ADKS Liquid and Suction Line Filter Drier

The ADKS is a replaceable core filter drier for use with CFC, HCFC, and HFC refrigerants in very large commercial air conditioning and refrigerant systems.

Features

- Full flow fittings for low pressure drop
- Corrosion resistant epoxy powder paint finish
- Sturdy steel shells for long life durability



Nomenclature example: ADKS 30013T

ADKS	300	13	T
System Protector Series	Unit Size (in cu. in.)	Connection Size (in 1/8")	T = Tap Access Connection

Dimensional Data

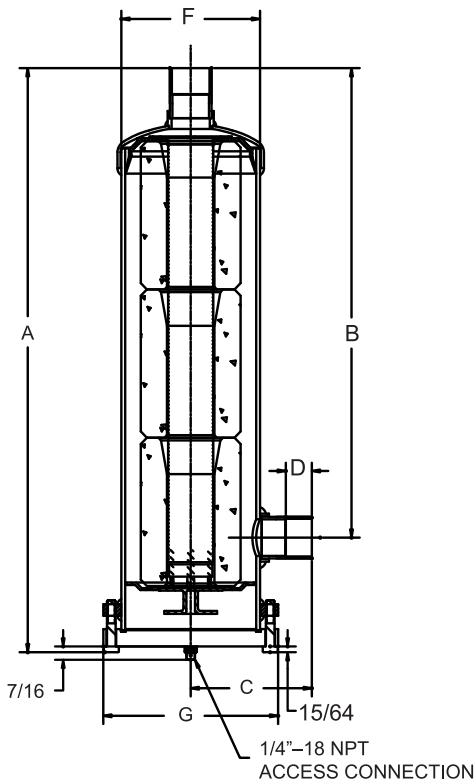

Specifications

- Filtration (with core): 40 microns
- Maximum working pressure: 500 psig*
- UL/CUL file number: SA 3124
- Bolt Torque: 35 ft-lbs

*Note: Not suitable for R-410A applications above 500 psig.

Ordering Information

PCN	Description	Connection Size	Number Of 100 in ³ Cores	Dimensions (in)						Weight (lbs)
				A	B	C	D	F*	G	
026570	ADKS-30013T	1 5/8 ODF	3	25.27	20.32	5.24	1.13	6.00	7.56	39.00
037978	ADKS-30017T	2 1/8 ODF		25.41	20.45	5.43	1.66			
032105	ADKS-40017T	2 1/8 ODF	4	31.91	26.95	5.43	1.66	6.00	7.56	46.00
037570	ADKS-40021T	2 5/8 ODF		32.81	27.86	6.19	1.47			

* Does not include weld bead

¹ *H* Dimension is the clearance required to change the internal hardware assembly

T = 1/4" FPT access connection

ADKS Models are shipped without filter cores or filter drier cores. See filter or filter drier cores for availability.

ADKS Liquid and Suction Line Filter Drier

Capacity Tables (in Tons)

Liquid Line for Replaceable Block Type ADKS Filter Driers

Description	Connection	Flow Capacity In Tons @ 1 psi ΔP ^{1, 2}					
		R-12	R-134a	R-22/R-410A	R-407C	R-404/507	R-502
ADKS 30013T	1 5/8 ODF	83	102	110	108	73	49
ADKS 30017T	2 1/8 ODF	121	148	160	157	107	59
ADKS 40017T	2 1/8 ODF	128	157	170	167	114	63
ADKS 40021T	2 5/8 ODF	136	166	180	177	120	71

¹ All ratings in accordance with ARI Standard 710-04. 86°F liquid refrigerant temperature
5°F saturated vapor temperature
3.1 lbs./min./ton for R-134a
2.9 lbs./min./ton for R-22 and R-407C
4.0 lbs./min./ton for R-404A/507 and R-12
² For 2 PSI ΔP. Multiply values by 1.4

Replacement Parts

Flange Cover	Description	PCN
ADKS-300, ADKS-400	X12176-2	027467
Shell	Strainer	Assembly
ADKS-300	X10574-5	039967
ADKS-400	X10574-6	038315
Miscellaneous Parts		
Gasket Set (Includes cover gasket)	X-11983-2	027454

Standard Product Offering

Exploded View

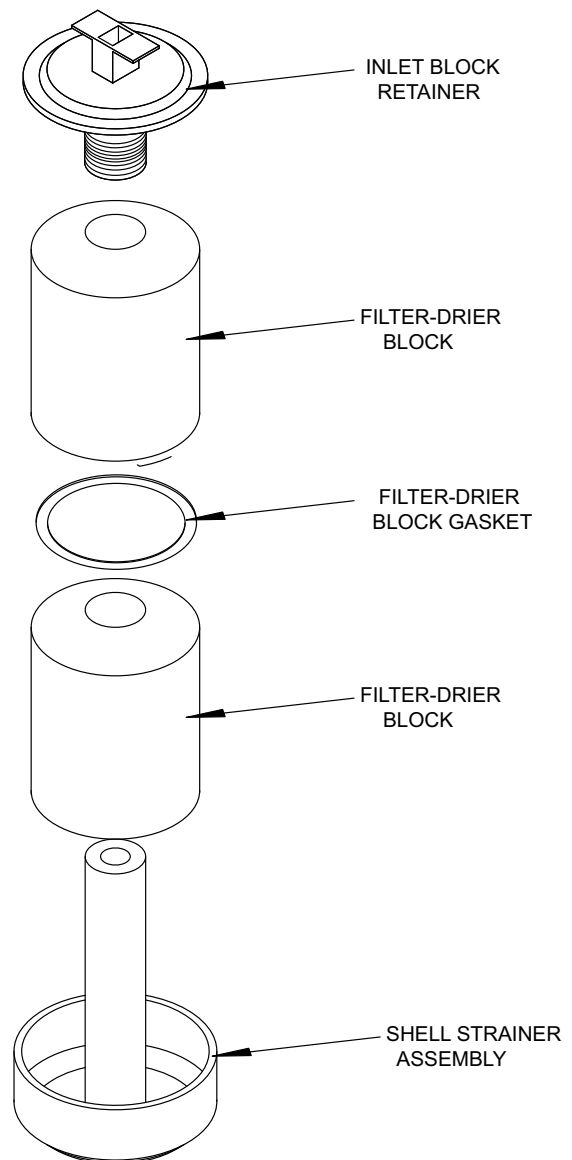

Filter Drier Cores and Filters

R-410A

Universal replacement cores and filter cores for use in our ADKS and STAS shells and similar competitive Take-Apart type filter drier shells. May not be used for BTAS.



Features

- Water capacities to suit specific system conditions
- Exceptional acid capacities for normal system protection, or to effectively clean-up following a compressor burnout
- Activated carbon blend for soluble contaminant and wax removal (W-HH Series)

Nomenclature example: H 48

H	48
Series	Cubic Inch

Specifications

- Interchangeable with competitive products

NOTE: Filter Drier cores are suitable for use with R-11 AND R-123 but filters are NOT.

Ordering Information and Capacity Tables

PCN	Description ³	Recommended Refrigerant Type	Function	Water Capacity ¹ Drops of Water ²													
				R-12		R-134a		R-22		R-407C		R-404A/R-507		R-410A		R-502	
				75°F	125°F	75°F	125°F	75°F	125°F	75°F	125°F	75°F	125°F	75°F	125°F	75°F	125°F
059541	D-48	CFC, HCFC	High Acid Removal	810	453	415	340	363	254	225	95	457	343	210	86	388	225
059542	H-48	CFC, HCFC	High Acid and Water Removal	1020	688	676	538	597	436	445	285	721	535	380	226	643	475
061235	W-48-HH	CFC, HCFC, HFC	Burnout Cleanup	772	488	387	294	335	226	290	165	417	289	249	130	444	306
061617	UK-48	CFC, HCFC, HFC	Universal Replacement	1579	1319	1272	1168	1181	1072	1033	786	1319	1241	976	707	1332	1150
089338	H-100	CFC, HCFC	High Acid and Water Removal	1958	1225	1112	834	962	673	726	418	1199	839	672	364	1109	758
062549	HX-48	CFC, HCFC, HFC	Highest Water Removal	1742	1581	1710	1600	1600	1491	1459	1161	1765	1710	1280	930	1932	1744
062424	UK-100	CFC, HCFC, HFC	Universal Replacement	3204	2740	2769	2550	2574	2345	2182	1682	2868	2710	-	-	2787	2437
043582	W-100-HH	CFC, HCFC, HFC	Burnout Cleanup	1668	1054	1077	812	938	621	629	363	1162	792	573	307	960	663
089559	F-48	CFC, HCFC, HFC	Filter (Suction Only)	N/A													
047664	F-48R	CFC, HCFC, HFC	Filter (Suction Only) Reverse Flow	N/A													
095762	F-100	CFC, HCFC, HFC	Filter (Suction Only)	N/A													
061237	RH-48	CFC, HCFC	Removal	1020	688	1096	920	1037	790	750	530	1090	940	650	420	643	475
061238	RW-48	CFC, HCFC	Cleanup	772	488	583	493	532	380	380	230	600	482	350	197	444	306

¹ Water Capacities are based on:
Equilibrium Point Dryness (EPD) of:
50 parts per million for R-134a, R404-A/R-410A and R-407C
60 parts per million for R-22
15 parts per million for R-12

² 20 drops of water = 1 gram = 1 cc

³ D-42, H-42 and W-42 include one neoprene composite lid gasket and one core gasket. All other cores include a universal neoprene composite gasket kit which includes 2 sizes of replacement lid gaskets, and gaskets for the top and bottom of the core or filter.

Standard Product Offering

Dimensional Data

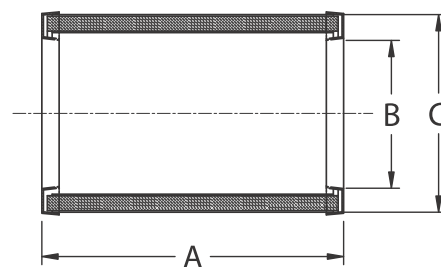
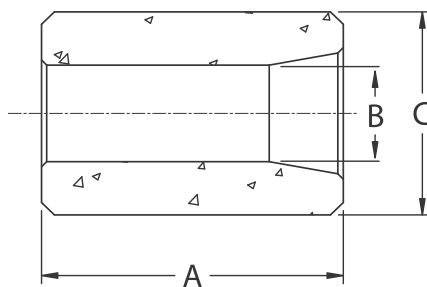

Filter Drier Block Size	Dimensions			Weight (lbs)
	A	B	C	
42	6.00	1.58	3.12	1.00
48	5.50	1.77	3.72	1.50
100	6.50	2.06	4.81	4.00

Catalog Number	Dimensions			Weight (lbs)
	A	B	C	
F-48/F-48R	5.50	2.81	3.88	0.75
F-100	6.50	3.75	4.81	1.50

BTAS Brass Take-Apart Suction Line Filter Drier

The BTAS is a replaceable core filter drier for suction line services ideal for commercial refrigeration applications.

Features

- Full flow fittings for low pressure drop
- Corrosion resistant brass body with stainless steel bolts
- Special cartridge design exclusive to brass shell



Nomenclature example: BTAS 311SV

BTAS	3	11	SV
Brass Take-Apart Series	Unit Size	Connection Size (in 1/8")	Suction Line Service

Specifications

- Filtration: 40 microns
- Maximum working pressure: 400 psig
- UL/CUL file number: SA 3124

Dimensional Data

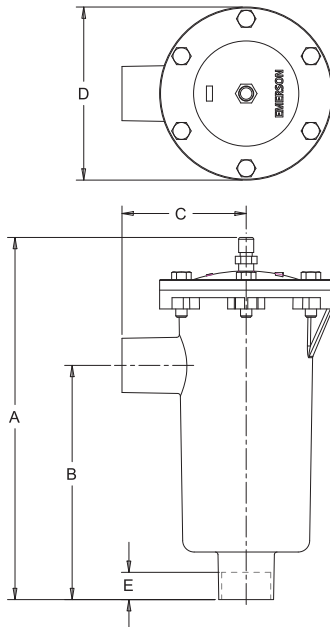

Ordering Information

PCN	Description	Connection Size	Nominal Shell Size (in)	Dimensions (in)					Weight (lbs)
				A	B	C	D	E	
049462	BTAS-27 S-V	7/8 ODF	2	9.75	6.57	2.19	3.75	0.75	6.75
049465	BTAS-39 S-V	1 1/8 ODF	3	10.31	6.81	3.31	4.63	0.91	10.25
049466	BTAS-311 S-V	1 3/8 ODF		11.06	6.94	3.44		0.97	10.50
049467	BTAS-313 S-V	1 5/8 ODF		11.25	7.13	3.63		1.09	11.00
049468	BTAS-317 S-V	2 1/8 ODF		11.50	7.38	3.88		1.34	11.20
064169	BTAS-411 S-V	1 3/8 ODF		11.41	7.81	4.13		5.75	0.78
049470	BTAS-413 S-V	1 5/8 ODF	12.03	7.81	4.13	1.09	16.75		
049471	BTAS-417 S-V	2 1/8 ODF	12.28	8.06	4.13	1.34	17.20		
049472	BTAS-421 S-V	2 5/8 ODF	12.41	8.19	4.94	1.47	18.00		
049473	BTAS-517 S-V	2 1/8 ODF	13.44	8.41	4.19	7.09	1.34		28.75
049474	BTAS-521 S-V	2 5/8 ODF	13.56	8.47	4.94		1.47	29.00	
049475	BTAS-525 S-V	3 1/8 ODF	13.25	8.16	4.63		1.66	29.25	

BTAS models are shipped without filter cartridge or Filter Drier cartridge.

Standard Product Offering

BTAS Brass Take-Apart Suction Line Filter Drier

Type A-F Replaceable Filter Cartridges

PCN	Filter Core	For Shell No.	Core O.D.	Core Length	Filter Area (Sq. In.)	Weight (lbs)
049479	A2F	BTAS-2	1 29/32	6 3/8	66	0.33
049480	A3F	BTAS-3	2 3/4	6 7/8	115	0.50
049481	A4F	BTAS-4	3 3/4	7 1/2	189	0.88
049482	A5F	BTAS-5	4 5/16	8 1/2	270	1.00

Type A-F-D Replaceable Filter Drier Cartridges

PCN	Filter Drier Cartridge	For Shell No.	Cartridge O.D.	Cartridge Length	Desiccant Volume (Cu. In.)	Weight (lbs)
049483	A2F-D	BTAS-2	1 29/32	6 3/8	4.2	0.50
049484	A3F-D	BTAS-3	2 3/4	6 7/8	13.3	0.88
049485	A4F-D	BTAS-4	3 3/4	7 1/2	26.0	1.20
049486	A5F-D	BTAS-5	4 5/16	8 1/2	36.5	1.20

Replacement Parts*

Misc. Parts	Description	PCN
Access Valve	X11562-2	037409
BTAS 2 Repair Kit*	KD-30519-2	065970
BTAS 3 Repair Kit*	KD-30519-3	065971
BTAS 4 Repair Kit*	KD-30519-4	065972
BTAS 5 Repair Kit*	KD-30519-5	065973
BTAS 2 Seal Ring Kit	KD-40015-1	066430
BTAS 3 Seal Ring Kit	KD-40015-2	066431
BTAS 4 Seal Ring Kit	KD-40015-3	066432
BTAS 5 Seal Ring Kit	KD-40015-4	066433

* Repair kits contain cover bolts, cover, spring and seal ring.

Standard Product Offering

Exploded View

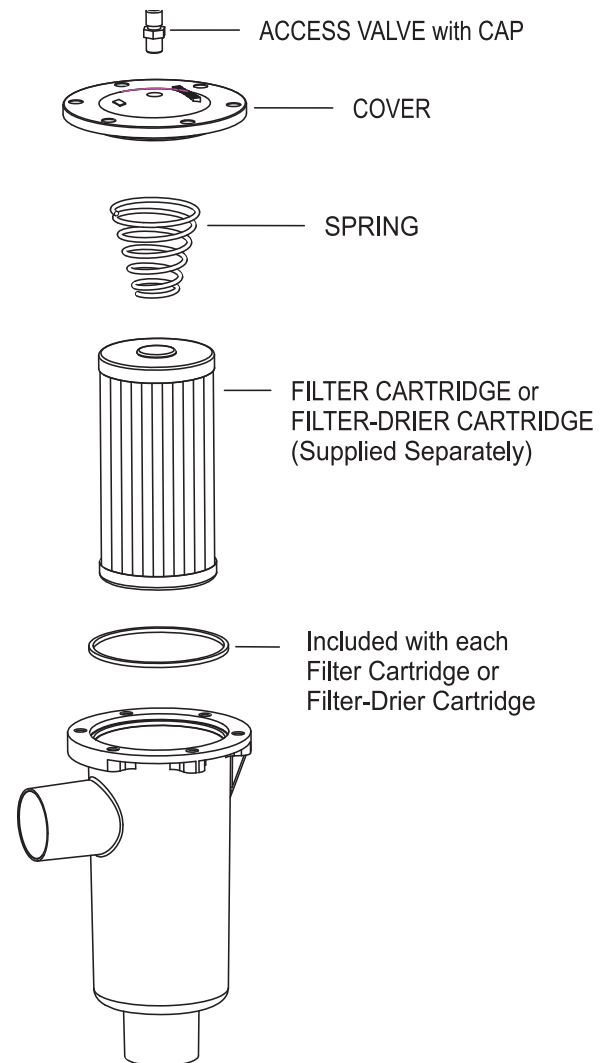

BTAS models are shipped without filter cartridge or Filter Drier cartridge.

ASD Premium Suction Line Filter Drier

R-410A

The ASD is a premium suction line filter drier for use with CFC, HCFC and HFC refrigerants. The ASD is optimized for high moisture, acid, and solid contaminant removal.

Features

- Outstanding filtration for ultimate compressor protection
- Dual access valves for easy pressure readings
- Solid copper connections
- Corrosion resistant epoxy powder paint finish



Specifications

- Filtration: 40 microns
- Maximum working pressure: 500 psig
- UL/CUL file number: SA 3124

Nomenclature example: ASD 35S5VV

ASD	35	S	5	VV
Series	Unit Size (in cu. in.)	Connections S = ODF F = SAE	Connection Size (in 1/8")	Dual Access Valves

Ordering Information

PCN	Description	Connection Size	Dimensions (in)					Weight (lbs)
			A	B	C	D	E	
056352	ASD 28F3	3/8 SAE	5.59	--	.044	4.13	3.69	2.00
049168	ASD 28S3-W	3/8 ODF	5.59	4.72	0.44	4.13		
049169	ASD 28S4-W	1/2 ODF	5.69	4.69	0.50	4.75	2.50	
049170	ASD 35F5-W	5/8 SAE	7.56	--	--			
049171	ASD 35S5-W	5/8 ODF	6.22	5.28	0.63	5.56	3.00	
049172	ASD 45S6-W	3/4 ODF	7.75	6.50	0.63			
049173	ASD 45S7-W	7/8 ODF	7.94	6.44	0.75	6.13	3.50	
049174	ASD 50S9-W	1 1/8 ODF	8.84	7.03	0.91			
049175	ASD 75S11-W	1 3/8 ODF	12.25	10.31	0.97	8.25	5.00	
049176	ASD 75S13-W	1 5/8 ODF	12.16	9.91	1.13			

Standard Product Offering

Dimensional Data

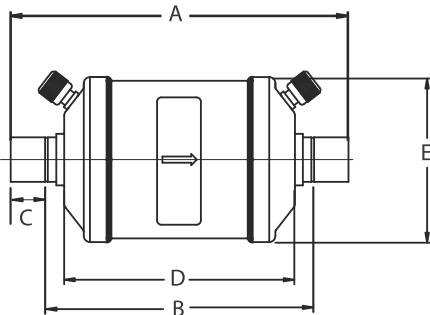

SFD Suction Line Filter Drier

The SFD is a standard suction line filter drier for use after a burnout or when major work has been performed. It is for use with CFC, HCFC and HFC refrigerants.

Features

- Solid copper connections
- Dual access valves for easy pressure readings
- Corrosion resistant epoxy powder paint finish
- R-410A compatible



Specifications

- Filtration: 40 microns
- Maximum working pressure: 500 psig
- UL/CUL file number: SA 3124

Nomenclature example: SFD 13S5-VV

SFD	13	S	5	VV
Series	Unit Size (in cu. in.)	Connections S = ODF F = SAE	Connection Size (in 1/8")	Dual Access Valves

Dimensional Data

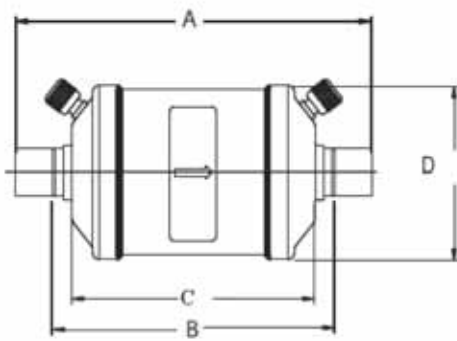

Order Information

PCN	Description	Connection Size	Dimensions (in)				Weight (lbs)
			A	B	C	D	
064045	SFD 08S4-W	1/2 ODF	4.94	3.94	3.38	3.14	2
064046	SFD 08S5-W	5/8 ODF	5.16	3.91			
064047	SFD 08S6-W	3/4 ODF	5.56	4.31			
060244	SFD 13F3-W	3/8 SAE	5.5	N/A			
060245	SFD 13S3-W	3/8 ODF	4.84	3.97			
060246	SFD 13S4-W	1/2 ODF	4.94	3.94		3.64	
060247	SFD 13F4-W	1/2 SAE	5.75	N/A			
060248	SFD 13F5-W	5/8 SAE	6.13	N/A			
060249	SFD 13S5-W	5/8 ODF	5.16	3.91			
060250	SFD 13S6-W	3/4 ODF	5.25	4			
060262	SFD 13S7-W	7/8 ODF	5.75	4.25			
056505	SFD 27S6-W	3/4 ODF	7	5.75	5.13		3
060251	SFD 27S7-W	7/8 ODF	7.5	6			
060252	SFD 27S9-W	1 1/8 ODF	7.63	5.81			
060253	SFD 54S11-W	1 3/8 ODF	12.25	10.31	8.25		4.5
060254	SFD 54S13-W	1 5/8 ODF	12.16	9.91			

Standard Product Offering

CSFD Compact Suction Line Filter Drier

The CSFD has a compact solid desiccant core perfect for short lay-in applications. The CSFD is used for moisture, acid and solid contaminant removal. It is for use with CFC, HCFC and HFC refrigerants.

Features

- Dual access valves for easy pressure readings
- High acid removal capacity
- Solid copper fittings for easiest brazing
- Corrosion resistant epoxy powder paint finish

Nomenclature example: CSFD 14S4-VV

CSFD	14	S	4	VV
Series	Unit Size	Connections S = ODF	Connection Size (in 1/8")	Dual Access Valves



Specifications

- Filtration: 40 microns
- Maximum working pressure: 500 psig
- UL/CUL file number: SA 3124

Dimensional Data

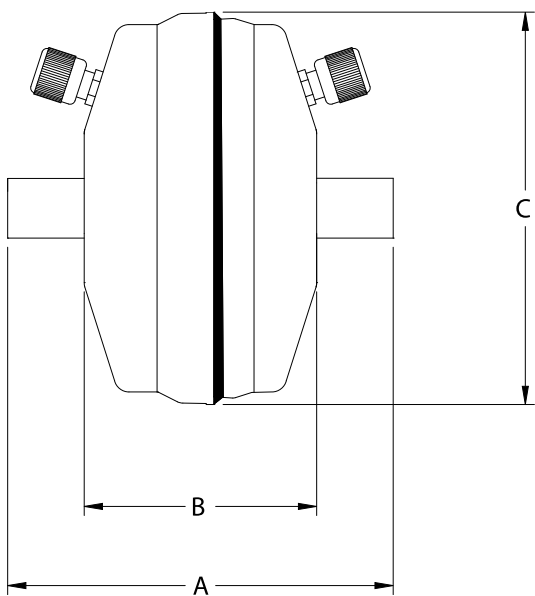

Ordering Information

PCN	Description	Connection Size	Dimensions (in)		
			A	B	C
062231	CSFD-14S4-W	1/2 ODF	4.25	2.75	4.63
062232	CSFD-14S5-W	5/8 ODF	4.50		
062233	CSFD-14S6-W	3/4 ODF	4.38		
062234	CSFD-14S7-W	7/8 ODF	4.56		
062235	CSFD-14S9-W*	1 1/8 ODF	4.88		

* 400 psig Maximum Working Pressure

Standard Product Offering

ASK-HH Suction Line Filter Drier

The ASK utilizes a solid core with an activated carbon blend to maximize acid, moisture and wax removal. It is for use with CFC, HCFC and HFC refrigerants.



Features

- Dual access valves for easy pressure readings
- Corrosion resistant epoxy powder paint finish
- Activated carbon blend for soluble contaminant and wax
- Solid copper connections

Specifications

- Filtration: 40 microns
- Maximum working pressure: 500 psig
- UL/CUL file number: SA 3124

Nomenclature example: ASK 165S-VV-HH

ASK	16	5	S	VV	HH
Series	Unit Size (in cu. in.)	Connection Size (in 1/8")	Connection S = ODF	Dual Access Valves	Charcoal Blend

Dimensional Data

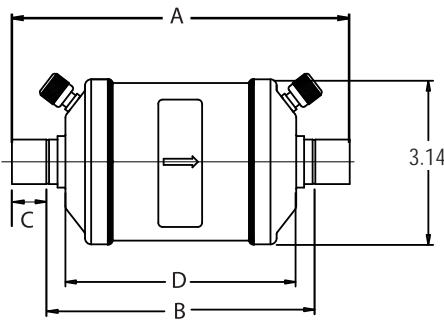

Ordering Information

PCN	Description	Connection Size	Dimensions (in)				Weight (lbs)
			A	B	C	D	
056508	ASK 165S-W-HH	5/8 ODF	6.38	5.13	0.63	4.63	2.00
056509	ASK 166S-W-HH	3/4 ODF	6.75	5.50	0.38		
056510	ASK 167S-W-HH	7/8 ODF	6.94	5.26	0.75	7.50	3.75
056511	ASK 306S-W-HH	3/4 ODF	9.69	8.56	0.63		
056512	ASK 307S-W-HH	7/8 ODF	9.88	8.38	0.75		
056513	ASK 309S-W-HH	1 1/8 ODF	10.19	8.38	0.94		

¹ Dimension does not include weld bead

Standard Product Offering

ASF Suction Line Filter

R-410A

The ASF is a specifically designed filter to protect the compressor from dirt and all solid contaminants.

Features

- Dual access valves for easy pressure readings
- Solid copper connections
- Corrosion resistant epoxy powder paint finish



Nomenclature example: ASF 35S5-VV

ASF	35	S	5	VV
Series	Unit Size (in cu. in.)	Connections S = ODF F = SAE	Connection Size (in 1/8")	Dual Access Valves

Specifications

- Filtration: 40 microns
- Maximum working pressure: 500 psig
- UL/CUL file number: SA 3124

Dimensional Data

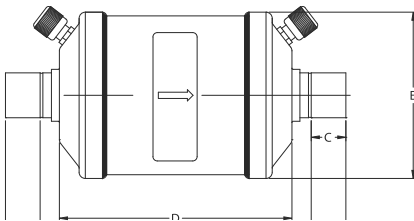

Ordering Information

PCN	Description	Connection Size	Dimensions					Weight (lbs)
			A	B	C	D	E*	
062961	ASF 11S4	1/2 ODF	4.38	3.38	0.50	2.88	2.63	1.50
062962	ASF 11S5	5/8 ODF	4.63	3.38	0.63	2.88	2.63	1.50
062963	ASF 28S7	7/8 ODF	6.50	5.00	0.75	4.13	3.06	2.00
062964	ASF 28S7-VV	1 1/8 ODF	7.41	5.61	0.91	4.13	3.06	2.00
049177	ASF 28S3-VV	3/8 ODF	5.59	4.72	0.44	4.13	3.69	2.00
049178	ASF 28S4-VV	1/2 ODF	5.69	4.69	0.50	4.13	3.69	2.00
049179	ASF 35F5-VV	5/8 SAE	7.56	-	-	4.75	3.69	2.50
049180	ASF 35S5-VV	5/8 ODF	6.53	5.28	0.63	4.75	3.69	2.50
059999	ASF 45F3-VV	3/8 SAE	7.69	-	-	5.56	3.69	3.00
049181	ASF 45S6-VV	3/4 ODF	7.75	6.50	0.63	5.56	3.69	3.00
049182	ASF 45S7-VV	7/8 ODF	7.94	6.44	0.75	5.56	3.69	3.00
049183	ASF 50S9-VV	1 1/8 ODF	8.84	7.03	0.91	6.13	5.00	3.50
063113	ASF 64S17-V	2 1/8 ODF	11.75	9.06	1.31	7.63	5.00	3.50
063115	ASF 64S21-V	2 5/8 ODF	13.00	10.00	1.50	7.88	5.00	3.50
049184	ASF 75S11-VV	1 3/8 ODF	12.25	10.31	0.97	8.25	5.00	5.00
049185	ASF 75S13-VV	1 5/8 ODF	12.16	9.91	1.13	8.25	5.00	5.00

* Dimension does not include weld bead

Standard Product Offering

Builder Series Filter Drier

The Builder Series filter drier provides an economical system protection for air conditioning applications.

Features

- ODF - Solid copper connections for easy installation
- Solid core construction
- 40 micron filtration
- Maximum working pressure = 680 psig



Nomenclature example: BS-L0835VV

BS	L	08	3	S	VV
Drier Series	L = Liquid S = Suction B = Bi Flow	Unit Size (in cu. in.)	Connection Size (in 1/8")	S = ODF connections (omit for SAE)	VV = Dual areas Valve (Suction Line Only)

Specifications

- Desiccant blend - optimized for high water capacity and acid capacity
- Filtration: 40 microns
- Maximum working pressure: 680 psig
- UL/CUL file number: SA 7175

Ordering Information Liquid Line Service

PCN	Model	Water Capacity drops R-22 @ 125 °F	Flow Capacity Tons *	
			R-22	R-410A
066122	BSL-053S	36	4.9	4.8
066123	BSL-083S	51	4.6	4.5
066125	BSL-084S	51	7.6	7.4
066098	BSL-163S	70	5.3	5.2
066099	BSL-164S	70	9.3	9.1

Suction Line Service

PCN	Model	Water Capacity drops R-22 @ 125 °F	Flow Capacity Tons +	
			R-22	R-410A
066126	BSS-165S	72	3.4	3.5
066127	BSS-166S	72	4.1	4.2
066128	BSS-167S	72	4.1	4.2
066100	BSS-305S	111	3.4	3.5
066101	BSS-306S	111	5.4	5.5
066129	BSS-307S	111	5.9	6.0
066102	BSS-309S	111	6.1	6.2

Bi-Flow Service

PCN	Model	Water Capacity drops R-22 @ 125 °F	Flow Capacity Tons *	
			R-22	R-410A
066130	BSB-083S	154	5.1	5.1
066131	BSB-163S	223	5.2	5.1

*Ratings in accordance with AHRI Standard 710

+ Ratings in accordance with AHRI Standard 730

APD Pulsation Dampener/Muffler

The APD series is designed to reduce noise and vibration on the compressor discharge lines.

Features

- Compact size
- Full flow fittings
- Solid copper connections
- Corrosion resistant epoxy powder paint finish
- Rugged steel shells for vibration resistance
- Shock resistant steel shell construction

Nomenclature example: APD 053 SB

APD	05	3	S	B
Pulsation Dampener	Cubic Inches	Fitting Size in 1/8"	ODF Fittings	With Baffles (omit for standard)

Dimensional Data

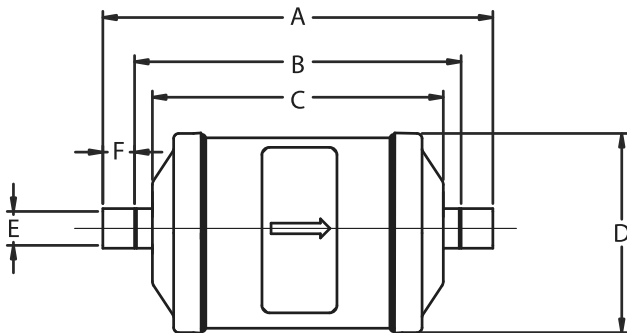

R-410A



Specifications

- Maximum working pressure: 680 psig
- Operating Range: -40°F to +250°F
- UL/CUL file number: SA 5760

Flow Capacity

Fitting Size	Tons
1/4	1-5
3/8	5-10
1/2	10-20
5/8	15-25
7/8	25-35
1 1/8	35+

Ordering Information

PCN	Description	Dimensions (in)					
		A	B	C	D	E	F
061862	APD 1R	6.00	5.00	4.47	3.02		
049651	APD 054 S-B	4.56	3.56	3.00		0.50	0.50
059144	APD 163 S	6.25	5.38		2.63	0.38	0.38
060119	APD 165 S-B	6.56	5.31	4.75		0.63	0.63
056989	APD 309 S	10.25	8.44	7.50	3.13	1.13	.88

Standard Product Offering

HMI Hermetic Moisture Indicators

R-410A

The HMI is designed to provide an accurate method of determining the moisture content of a system's refrigerant. The HMI has a unique high accuracy moisture indicator for CFC, HCFC, and HFC refrigerants.



Features

- Highest sensitivity moisture indicator available
- Hermetic, leak-free construction
- Single indicator for all common refrigerants
- Accurate color calibration at low ppm levels and higher temperatures
- Wide angle viewing/high visibility window for ease of monitoring
- All brass corrosion resistant body for fewer leaks
- Solid copper connections

Specifications

- Maximum working pressure: 680 psig
- UL/CUL file number: SA 9566

Nomenclature example: HMI 1TT4

HMI	1	TT	4
Hermetic Moisture Indicator	Series	Connection Style TT = Sweat x Sweat	Connection Size (in 1/8")

Ordering Information

PCN	Description	Series	Connection Size	
065391	HMI-1MM2	Male Flare x Male Flare	1/4	
065392	HMI-1MM3		3/8	
065393	HMI-1MM4		1/2	
065394	HMI-1MM5		5/8	
065395	HMI-1MM6		3/4	
065405	HMI-1TT2		Sweat x Sweat (ODF)	1/4
065406	HMI-1TT3	3/8		
065407	HMI-1TT4	1/2		
065408	HMI-1TT5	5/8		
065409	HMI-1TT6	3/4		
065410	HMI-1TT7	7/8		
065411	HMI-1TT9	1 1/8		
065396	HMI-1FM2	Female Flare x Male Flare		1/4
065397	HMI-1FM3			3/8
065398	HMI-1FM4		1/2	
065622	HMI-1TT2MF	Sweat x Sweat (ODM x ODF)	1/4	
065814	HMI-1TT3MF		3/8	
065979	HMI-1TT4MF		1/2	
065980	HMI-1TT5MF		5/8	

Standard Product Offering

Moisture Content Color Code (ppm H₂O)

Indication Liquid Temperature	Dry (Dark Blue)			Caution (Purple)			Wet (Salmon)		
	75°F	100°F	125°F	75°F	100°F	125°F	75°F	100°F	125°F
R-12	1.4	2.5	4	5	9	15	25	43	70
R-134A	20	35	60	35	55	85	130	160	190
R-22	25	35	50	40	65	90	145	205	290
R-407C	26	40	64	42	68	109	150	230	370
R-410A	30	55	75	50	85	120	165	290	420
R-404A/507	15	25	45	33	50	80	120	150	180

Indication Liquid Temperature	Dry (Dark Blue)				Caution (Purple)				Wet (Salmon)			
	-40°F	-4°F	32°F	68°F	-40°F	-4°F	32°F	68°F	-40°F	-4°F	32°F	68°F
R-744	3	6	11	20	5	10	19	34	16	32	63	116

HMI Hermetic Moisture Indicators

Dimensional Data

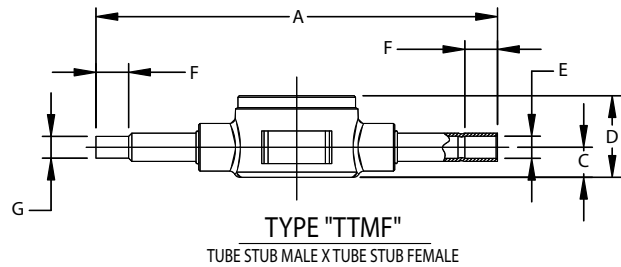
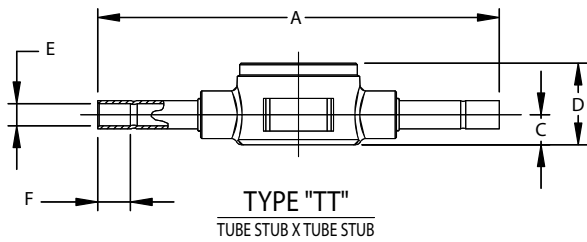
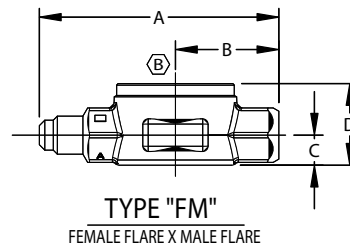
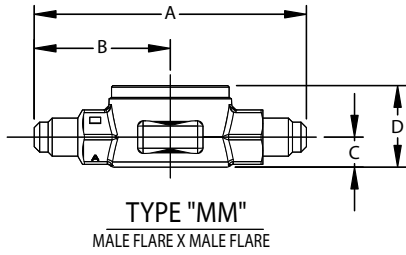

Dimensional Data (in)

Type Number	Connection Size	A	B	C	D	E	F Min	G
HMI - 1MM2	1/4 SAE	3.13	1.56	0.34	0.94			
HMI - 1MM3	3/8 SAE	3.38	1.69	0.34	0.94			
HMI - 1MM4	1/2 SAE	3.62	1.81	0.47	1.19			
HMI - 1MM5	5/8 SAE	3.88	1.94	0.47	1.19			
HMI - 1MM6	3/4 SAE	5.00	2.50	0.59	1.53			
HMI - 1FM2	1/4 SAE FM	2.75	1.19	0.34	0.94			
HMI - 1FM3	3/8 SAE FM	3.00	1.31	0.47	1.19			
HMI - 1FM4	1/2 SAE FM	3.22	1.41	0.47	1.19			
HMI - 1TT2	1/4 ODF	5.56		0.34	0.94	0.25	0.38	
HMI - 1TT3	3/8 ODF	5.61		0.34	0.94	0.38	0.40	
HMI - 1TT4	1/2 ODF	5.87		0.47	1.19	0.50	0.50	
HMI - 1TT5	5/8 ODF	5.87		0.61	1.19	0.63	0.63	
HMI - 1TT6	3/4 ODF	6.56		0.61	1.50	0.75	0.63	
HMI - 1TT7	7/8 ODF	6.31		0.61	1.50	0.88	0.75	
HMI - 1TT9	1 1/8 ODF	6.59		0.67	1.37	1.13	0.90	
HMI - 1TT2MF	1/4 ODM x 1/4 ODF	5.56		0.34	0.94	0.25	0.38	0.25
HMI - 1TT3MF	3/8 ODM x 3/8 ODF	5.61		0.34	0.94	0.38	0.38	0.38
HMI - 1TT4MF	1/2 ODM x 1/2 ODF	5.87		0.47	1.19	0.50	0.50	0.50
HMI - 1TT5MF	5/8 ODM x 5/8 ODF	5.87		0.61	1.19	0.63	0.50	0.62

AMI Moisture Indicators

R-410A

The AMI is designed to provide an accurate method of determining the moisture content of a system's refrigerant. The AMI has a unique high accuracy moisture indicator for CFC, HCFC and HFC refrigerants. For the AMI-2 Series, see the bottom of the following page.



Features

- Highest sensitivity moisture indicator available
- Take-Apart design for easy repair
- Single indicator for all common refrigerants
- Accurate color calibration at low ppm levels and higher temperatures
- Wide angle viewing/high visibility window for ease of monitoring
- Solid copper connections

Specifications

- Maximum working pressure: 650 psig
- UL/CUL file number: SA 9566

Nomenclature example: AMI 1SS4

AMI	1	SS	4
Moisture Indicator Series	Design Series 1 = standard connection 2 = bushing style	Connection Style TT = Sweat x Sweat	Connection Size (in 1/8")

Replacement Parts For AMI

PCN	Part	Number
021371	Lenscap	12740-1
020877	"O" Ring	PS1525-2
027511	Lens Assembly Kit (Consists of lens assembly, lens cap and "O" ring)	X12978-1

Standard Product Offering

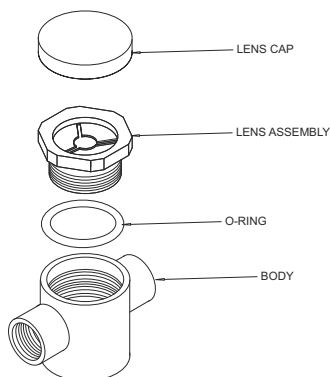

Ordering Information

PCN	Description	Series	Connection Size
048804	AMI-1MM3	Male Flare x Male Flare	3/8
048805	AMI-1MM4		1/2
048806	AMI-1MM5		5/8
048811	AMI-1SS2	Sweat x Sweat (OD Female)	1/4
048812	AMI-1SS3		3/8
048813	AMI-1SS4		1/2
048814	AMI-1SS5		5/8
048815	AMI-1SS7		7/8
048816	AMI-1SS9		1 1/8
047298	AMI-1TT2 EXTENDED ENDS		1/4
042771	AMI-1TT3 EXTENDED ENDS		3/8
022302	AMI-1TT4 EXTENDED ENDS		1/2
031136	AMI-1TT5 EXTENDED ENDS	5/8	
031357	AMI-1TT7 EXTENDED ENDS	7/8	
031578	AMI-1TT9 EXTENDED ENDS	1 1/8	
048800	AMI-1FM2	Female Flare x Male Flare	1/4
048801	AMI-1FM3		3/8
048802	AMI-1FM4		1/2

Standard Product Offering

Moisture Content Color Code (ppm H₂O)

Indication Liquid Temperature	Dry (Dark Blue)			Caution (Purple)			Wet (Salmon)		
	75°F	100°F	125°F	75°F	100°F	125°F	75°F	100°F	125°F
R-12	1.4	2.5	4	5	9	15	25	43	70
R-134A	20	35	60	35	55	85	130	160	190
R-22	25	35	50	40	65	90	145	205	290
R-407C	26	40	64	42	68	109	150	230	370
R-410A	30	55	75	50	85	120	165	290	420
R-404A/507	15	25	45	33	50	80	120	150	180

Indication Liquid Temperature	Dry (Dark Blue)				Caution (Purple)				Wet (Salmon)			
	-40°F	-4°F	32°F	68°F	-40°F	-4°F	32°F	68°F	-40°F	-4°F	32°F	68°F
R-744	3	6	11	20	5	10	19	34	16	32	63	116

AMI Moisture Indicators

AMI-1

Dimensional Data

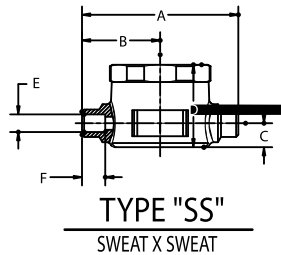
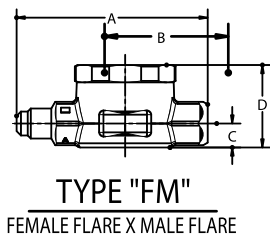
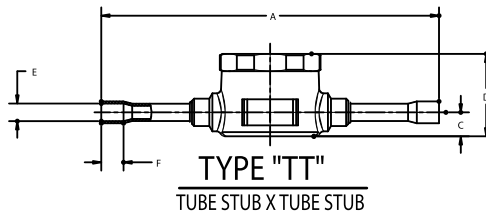
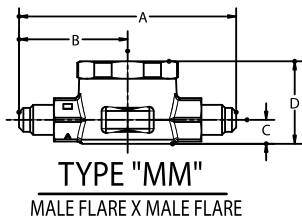

AMI-1 Dimensional Data (in)

Description	Connection Size	A	B	C	D	E	F Min.
AMI-1MM2	1/4 SAE	3.13	1.56	0.34	1.19		
AMI-1MM3	3/8 SAE	3.38	1.69				
AMI-1MM4	1/2 SAE	3.63	1.81	0.47	1.44		
AMI-1MM5	5/8 SAE	3.88	1.94				
AMI-1FM2	1/4 SAE	2.75	1.19	0.34	1.19		
AMI-1FM3	3/8 SAE	3.00	1.31	0.47	1.44		
AMI-1FM4	1/2 SAE	3.22	1.41				
AMI-1SS2	1/4 ODF	2.25	1.13	0.34	1.19	0.25	.32
AMI-1SS3	3/8 ODF					0.38	.32
AMI-1SS4	1/2 ODF	2.63	1.31	0.47	1.44	0.50	.38
AMI-1SS5	5/8 ODF					0.63	.50
AMI-1SS7	7/8 ODF					3.13	1.56
AMI-1SS9	1 1/8 ODF	3.38	1.69	0.67	1.92	1.13	.90
AMI-1TT2	1/4 ODF	4.89		0.34	1.19	.25	.32
AMI-1TT3	3/8 ODF					0.38	.32
AMI-1TT4	1/2 ODF	4.92		0.47	1.44	0.50	.38
AMI-1TT5	5/8 ODF	4.91				0.63	.50
AMI-1TT7	7/8 ODF	6.36		0.61	1.75	0.88	.76
AMI-1TT9	1 1/8 ODF	6.59		0.67	1.92	1.125	.90
AMI-1TT11	1 3/8 ODF	6.94		1.00	2.39	1.38	1.3

AMI-2 Series Dimensions (in)

PCN	Description	Connection Size	A Dia.	B	C
064167	AMI-2S7	7/8 ODM	0.88	1.34	1.00
064168	AMI-2S9	1 1/8 ODM	1.13	1.25	1.00
022303	AMI-2S11	1 3/8 ODM	1.38	1.56	1.94
028388	AMI-2S13	1 5/8 ODM	1.63	1.69	1.44
031219	AMI-2S17	2 1/8 ODM	2.13	1.94	1.69

Standard Product Offering

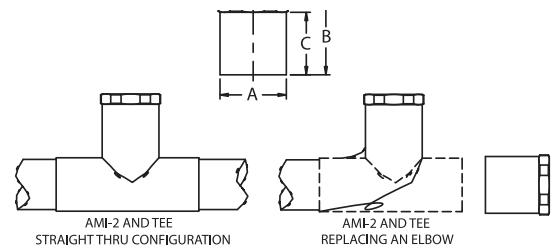

A-IHL Moisture Indicators

The A-IHL saddle design moisture indicator is used for large diameter tubing in CFC, HCFC, and HFC refrigerants.

Features

- Saddle design
- Solid copper connections
- Replaceable moisture indicator
- Eliminates the need for bypass installation - positive reaction to system moisture levels

Specifications

- Maximum working pressure: 680 psig
- UL/CUL file number: SA 9566

Nomenclature example: A-IHL 9S

A-IHL	9	S
Series	Connection Size (in 1/8")	S = ODF



Ordering Information

PCN	Model	Connection Size	Overall Length
060853	A-IHL-9S	1 1/8 ODF	6.31
061030	A-IHL-11S	1 3/8 ODF	7.12
061031	A-IHL-13S	1 5/8 ODF	7.87
061032	A-IHL-17S	2 1/8 ODF	8.68
*060973	*A-IHL-21S	2 5/8 ODF	9.45

* A-IHL-21S has a maximum working pressure of 500 psig

Standard Product Offering

A-AS Suction Accumulators

The A-AS protects the compressor from liquid slugging and is used with CFC, HCFC, and HFC refrigerants. It is available for systems through 28 tons nominal capacity.

Features

- Designed to operate in a range of +40°F to -40°F evaporator temperature
- Fusible plug on larger diameter units
- Solid copper connections
- Corrosion resistant epoxy powder paint finish
- Inlet deflector directs refrigerant flow to prevent internal splashing and aid in the collection of refrigerant oil



Nomenclature example: A-AS 3 125

A	AS	3	12	5
Series	Accumulator Suction	Diameter (in)	Height (in)	Fitting Size in 1/8"

Specifications

- Maximum working pressure: 300 psig
- Fusible plug temperature: 430°F
- UL/CUL file number: SA 10225

Ordering Information and Dimensional Data (in)

PCN	Description	A Fitting Size (nominal)	B Diameter	C Height	D Fitting Separation	Weight (lbs)	Tons R-22 (+40°F)	Holding Capacity (lbs) 50% Full	
								40°F Liquid R-22/R-134a	40°F Liquid R-404A/R-507
060819	A-AS 3 84*	1/2	3.00	8.00	1.63	2.00	2.00	1.50	1.50
060963	A-AS 3 105*	5/8	3.00	10.00	1.63	2.40	3.00	2.00	2.00
060812	A-AS 3 125*	5/8	3.00	12.00	1.63	2.90	3.00	3.00	2.50
060813	A-AS 3 126*	3/4	3.00	12.00	1.63	2.90	4.00	3.00	2.50
060964	A-AS 3 145*	5/8	3.00	15.00	1.63	3.30	3.00	3.50	3.00
060965	A-AS 3 146*	3/4	3.00	14.00	1.63	3.30	4.00	3.50	2.75
060967	A-AS 4 64	1/2	4.00	6.00	2.50	2.80	2.00	2.50	2.00
060821	A-AS 4 65	5/8	4.00	6.00	2.50	2.80	3.00	2.50	2.00
060966	A-AS 4105	5/8	4.00	10.00	2.50	4.60	3.00	4.00	3.50
060820	A-AS 4 106	3/4	4.00	10.00	2.50	4.60	4.00	4.00	3.50
060824	A-AS 5 96	3/4	5.00	9.00	2.75	5.10	4.00	6.00	5.50
060818	A-AS 5 97	7/8	5.00	9.00	2.75	5.10	7.30	6.00	5.50
060822	A-AS 5 126	3/4	5.00	12.00	2.75	6.60	4.00	8.00	7.50
060823	A-AS 5 127	7/8	5.00	12.00	2.75	6.60	7.30	8.00	7.50
060814	A-AS 5 137	7/8	5.00	13.00	2.75	7.10	7.30	8.50	8.00
060815	A-AS 5 139	1-1/8	5.00	13.00	2.75	7.10	11.80	8.50	8.00
060817	A-AS 5 179	1-1/8	5.00	17.00	2.75	8.40	11.80	12.00	10.00
060816	A-AS 5 1711	1-3/8	5.00	17.00	2.75	8.40	18.80	12.00	10.00
060825	A-AS 6 117	7/8	6.00	11.00	2.94	10.00	7.30	10.00	9.00
060826	A-AS 6 137	7/8	6.00	13.00	2.94	11.70	7.30	12.84	11.49
060968	A-AS 6 139	1-1/8	6.00	13.00	2.94	11.70	11.80	12.84	11.49
060827	A-AS 6 1411	1-3/8	6.00	14.00	2.94	12.10	18.80	14.05	12.57
060969	A-AS 6 1713	1-5/8	6.00	17.00	2.94	15.40	28.50	17.32	15.49
060828	A-AS 6 2013	1-5/8	6.00	20.00	2.94	18.10	28.50	20.62	18.44
060970	A-AS 6 2513	1-5/8	6.00	25.00	2.94	22.60	28.50	25.81	23.08

*Not supplied with a fusible plug

Standard Product Offering

Dimensional Data

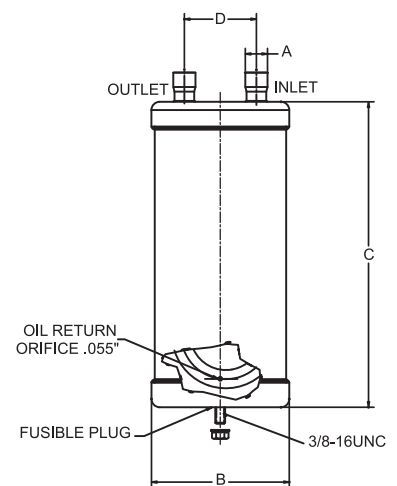

Hermetic Suction Line Filter Drier Flow Capacities

Description	Connections	Flow Capacity In Tons Refrigerant ¹ (For kW, Multiply Tons By 3.5) ²											
		R-12				R-134a				R-744			
		Evaporator Temperature (°F)											
		40	20	0	-20	40	20	0	-20	20	0	-20	-40
		Pressure Drop (PSI)											
2	1.5	1	0.5	2	1.5	1	0.5	6	5	4	3		
ASD 28S3-VV	3/8 ODF	1.1	0.6	0.5	0.5	1.1	0.6	0.5	0.4	7.2	6.3	6.8	8.5
ASD 28S4-VV	1/2 ODF	1.8	1.2	0.8	0.7	1.9	1.2	0.8	0.6	11.8	10.2	10.6	14.2
ASD 35F5-VV	5/8 SAE	2.1	1.4	1.1	0.9	2.2	1.4	1.0	0.8	13.7	12.2	12.9	17.0
ASD 35S5-VV	5/8 ODF	2.8	1.9	1.4	1.1	2.9	1.9	1.3	1.0	18.1	15.6	16.7	22.7
ASD 45S6-VV	3/4 ODF	3.8	2.5	1.8	1.2	3.9	2.5	1.7	1.1	21.8	22.4	24.2	28.4
ASD 45S7-VV	7/8 ODF	5.0	3.6	2.3	1.5	5.1	3.5	2.2	1.3	28.7	29.2	31.1	36.9
ASD 50S9-VV	1-1/8 ODF	7.1	5.0	3.2	1.8	7.3	4.9	3.0	1.6	41.1	41.3	43.2	49.6
ASD 75S11-VV	1-3/8 ODF	8.6	5.9	3.7	2.0	8.8	5.8	3.5	1.8	50.5	49.6	50.8	56.7
ASD 75S13-VV	1-5/8 ODF	9.0	6.2	3.9	2.1	9.3	6.1	3.7	1.9	53.9	52.0	53.0	59.6
ASF 28S3-VV	3/8 ODF	1.2	0.8	0.5	0.5	1.2	0.8	0.5	0.4	7.5	6.3	6.8	9.9
ASF 28S4-VV	1/2 ODF	1.9	1.3	0.9	0.8	2.0	1.3	0.9	0.7	12.8	11.2	12.1	17.0
ASF 35F5-VV	5/8 SAE	2.2	1.5	1.1	0.9	2.3	1.5	1.0	0.8	14.6	12.6	13.6	18.4
ASF 35S5-VV	5/8 ODF	3.2	2.2	1.6	1.4	3.3	2.2	1.5	1.2	20.6	18.0	19.7	26.9
ASF 45S6-VV	3/4 ODF	4.7	3.2	2.3	1.8	4.8	3.1	2.2	1.6	30.5	26.7	28.0	38.3
ASF 45S7-VV	7/8 ODF	6.5	4.8	3.3	1.9	6.7	4.7	3.1	1.7	37.4	38.9	42.4	51.0
ASF 50S9-VV	1-1/8 ODF	9.2	6.8	4.5	2.6	9.5	6.7	4.3	2.3	59.2	58.3	62.1	69.5
ASF 64S17-VV	2-1/8 ODF	25.3	18.3	12.6	7.2	26.0	18	12	6.4	127.8	131.2	144.0	170.2
ASF 75S11-VV	1-3/8 ODF	11.7	8.8	5.9	3.4	12.0	8.7	5.6	3.0	49.9	72.9	83.4	95.0
ASF 75S13-VV	1-5/8 ODF	13.6	9.7	6.6	3.8	14.0	9.5	6.3	3.4	74.8	72.9	75.8	92.2
ASK 165S-VV-HH	5/8 ODF	1.9	1.4	0.8	0.6	2.0	1.4	0.8	0.5	10.6	10.2	10.6	12.8
ASK 166S-VV-HH	3/4 ODF	2.4	1.7	1.1	0.7	2.5	1.7	1.0	0.6	13.1	12.6	12.9	14.2
ASK 167S-VV-HH	7/8 ODF	2.6	1.8	1.2	0.7	2.7	1.8	1.1	0.6	14.3	13.6	14.4	15.6
ASK 306S-VV-HH	3/4 ODF	3.3	2.3	1.5	0.9	3.4	2.3	1.4	0.8	17.1	17.0	17.4	19.9
ASK 307S-VV-HH	7/8 ODF	3.5	2.5	1.6	0.9	3.6	2.5	1.5	0.8	19.0	18.5	18.9	21.3
ASK 309S-VV-HH	1-1/8 ODF	3.8	2.6	1.7	0.9	3.9	2.6	1.6	0.8	20.3	19.4	19.7	22.7
CSFD 14S4-VV	1/2 ODF	1.3	0.9	0.5	0.3	1.3	0.9	0.5	0.3	6.2	6.3	6.8	8.5
CSFD 14S5-VV	5/8 ODF	2.2	1.5	0.9	0.6	2.3	1.5	0.9	0.5	11.2	11.7	12.1	14.2
CSFD 14S6-VV	3/4 ODF	3.0	2.1	1.3	0.8	3.1	2.1	1.3	0.7	15.3	15.6	16.7	19.9
CSFD 14S7-VV	7/8 ODF	3.2	2.2	1.5	0.8	3.3	2.2	1.4	0.7	16.2	16.5	17.4	21.3
CSFD 14S9-VV	1-1/8 ODF	4.4	3.1	1.9	1.1	4.5	3.0	1.8	1.0	21.8	22.4	23.5	28.4
SFD 13F3-VV	3/8 SAE	0.7	0.4	0.2	0.1	0.7	0.4	0.2	0.1	4.4	3.9	3.0	2.8
SFD 13S3-VV	3/8 ODF	1.3	0.8	0.5	0.2	1.3	0.8	0.5	0.2	6.9	6.3	6.1	7.1
SFD 13F4-VV	1/2 SAE	1.5	1.0	0.6	0.3	1.5	1.0	0.6	0.3	7.5	7.8	8.3	9.9
SFD 13S4-VV	1/2 ODF	2.2	1.5	1.1	0.6	2.3	1.5	1.0	0.5	10.9	11.2	12.1	14.2
SFD 13F5-VV	5/8 SAE	2.4	1.7	1.2	0.7	2.5	1.7	1.1	0.6	11.5	11.7	12.1	14.2
SFD 13S5-VV	5/8 ODF	3.0	2.1	1.4	0.8	3.1	2.1	1.3	0.7	15.3	15.6	16.7	19.9
SFD 13S6-VV	3/4 ODF	4.0	2.7	1.8	1.0	4.1	2.7	1.7	0.9	19.9	20.4	21.2	25.5
SFD 13S7-VV	7/8 ODF	4.3	3.1	2.0	1.1	4.4	3.0	1.9	1.0	22.4	22.4	22.7	26.9
SFD 27S6-VV	3/4 ODF	4.0	2.7	1.8	1.0	4.1	2.7	1.7	0.9	19.9	20.4	21.2	25.5
SFD 27S7-VV	7/8 ODF	4.6	3.2	2.0	1.1	4.7	3.1	1.9	1.0	23.4	23.3	24.2	28.4
SFD 27S9-VV	1-1/8 ODF	5.1	3.5	2.1	1.1	5.2	3.4	2.0	1.0	26.5	26.2	26.5	29.8
SFD 54S11-VV	1-3/8 ODF	4.4	2.9	1.8	1.0	4.5	2.9	1.7	0.9	22.8	22.4	22.7	25.5
SFD 54S13-VV	1-5/8 ODF	4.5	3.1	1.9	1.0	4.6	3.0	1.8	0.9	23.1	22.8	24.2	28.4

¹ All ratings in accordance with ARI Standard 730-04.

² Example: 1.0 tons x 3.5 = 3.5 kW

Hermetic Suction Line Filter Drier Flow Capacities

Description	Connections	Flow Capacity In Tons Refrigerant ¹ (For kW, Multiply Tons By 3.5) ²														
		R-22					R-407C					R-410A				
		Evaporator Temperature (°F)														
		40	20	0	-20	-40	40	20	0	-20	-40	40	20	0	-20	-40
		Pressure Drop (PSI)														
3	2	1.5	1	0.5	3	2	1.5	1	0.5	3	2	1.5	1	0.5		
ASD 28S3-VV	3/8 ODF	2.3	1.3	0.9	0.6	0.5	2.1	1.2	0.8	0.5	0.4	2.8	1.6	1.1	0.7	0.6
ASD 28S4-VV	1/2 ODF	3.8	2.1	1.4	1.0	0.8	3.5	1.9	1.2	0.9	0.7	4.6	2.6	1.7	1.2	1.0
ASD 35F5-VV	5/8 SAE	4.4	2.5	1.7	1.2	0.9	4.1	2.3	1.5	1.0	0.7	5.3	3.0	2.1	1.5	1.1
ASD 35S5-VV	5/8 ODF	5.8	3.2	2.2	1.6	1.0	5.4	2.9	1.9	1.4	0.8	7.0	3.9	2.7	2.0	1.3
ASD 45S6-VV	3/4 ODF	7.0	4.6	3.2	2.0	1.1	6.5	4.2	2.8	1.7	0.9	8.5	5.6	3.9	2.5	1.4
ASD 45S7-VV	7/8 ODF	9.2	6.0	4.1	2.6	1.4	8.5	5.5	3.6	2.3	1.2	11.2	7.3	5.0	3.2	1.8
ASD 50S9-VV	1-1/8 ODF	13.2	8.5	5.7	3.5	1.8	12.2	7.7	5.0	3.1	1.5	16.0	10.3	7.0	4.3	2.3
ASD 75S11-VV	1-3/8 ODF	16.2	10.2	6.7	4.0	2.0	15.0	9.3	5.9	3.5	1.7	19.6	12.4	8.2	5.0	2.5
ASD 75S13-VV	1-5/8 ODF	17.3	10.7	7.0	4.2	2.1	16.0	9.7	6.2	3.7	1.7	21.0	13.0	8.6	5.2	2.6
ASF 28S3-VV	3/8 ODF	2.4	1.3	0.9	0.7	0.5	2.2	1.2	0.8	0.6	0.4	2.9	1.6	1.1	0.9	0.6
ASF 28S4-VV	1/2 ODF	4.1	2.3	1.6	1.2	0.9	3.8	2.1	1.4	1.0	0.7	5.0	2.8	2.0	1.5	1.1
ASF 35F5-VV	5/8 SAE	4.7	2.6	1.8	1.3	1.0	4.4	2.4	1.6	1.1	0.8	5.7	3.2	2.2	1.6	1.3
ASF 35S5-VV	5/8 ODF	6.6	3.7	2.6	1.9	1.6	6.1	3.4	2.3	1.7	1.3	8.0	4.5	3.2	2.4	2.0
ASF 45S6-VV	3/4 ODF	9.8	5.5	3.7	2.7	2.2	9.1	5.0	3.3	2.4	1.8	11.9	6.7	4.5	3.4	2.8
ASF 45S7-VV	7/8 ODF	12.0	8.0	5.6	3.6	3.0	11.1	7.3	5.0	3.1	2.5	14.6	9.7	6.9	4.5	3.8
ASF 50S9-VV	1-1/8 ODF	19.0	12.0	8.2	4.9	2.6	17.6	10.9	7.3	4.3	2.2	23.0	14.6	10.1	6.1	3.3
ASF 64S17-VV	2-1/8 ODF	41.0	27.0	19.0	12.0	6.9	38.0	24.5	16.8	10.5	5.7	49.7	32.8	23.3	14.9	8.6
ASF 75S11-VV	1-3/8 ODF	16.0	15.0	11.0	6.7	3.3	14.8	13.6	9.7	5.8	2.7	19.4	18.2	13.5	8.3	4.1
ASF 75S13-VV	1-5/8 ODF	24.0	15.0	10.0	6.5	3.2	22.2	13.6	8.9	5.7	2.7	29.1	18.2	12.3	8.1	4.0
ASK 16S5-VV-HH	5/8 ODF	3.4	2.1	1.4	0.9	0.4	3.2	1.9	1.2	0.8	0.3	4.1	2.6	1.7	1.1	0.5
ASK 16S5-VV-HH	3/4 ODF	4.2	2.6	1.7	1.0	0.5	3.9	2.4	1.5	0.9	0.4	5.1	3.2	2.1	1.2	0.6
ASK 16S7-VV-HH	7/8 ODF	4.6	2.8	1.9	1.1	0.6	4.3	2.5	1.7	1.0	0.5	5.6	3.4	2.3	1.4	0.8
ASK 30S6-VV-HH	3/4 ODF	5.5	3.5	2.3	1.4	0.8	5.1	3.2	2.0	1.2	0.7	6.7	4.3	2.8	1.7	1.0
ASK 30S7-VV-HH	7/8 ODF	6.1	3.8	2.5	1.5	0.8	5.7	3.5	2.2	1.3	0.7	7.4	4.6	3.1	1.9	1.0
ASK 30S9-VV-HH	1-1/8 ODF	6.5	4.0	2.6	1.6	0.8	6.0	3.6	2.3	1.4	0.7	7.9	4.9	3.2	2.0	1.0
CSFD 14S4-VV	1/2 ODF	2.0	1.3	0.9	0.6	0.3	1.9	1.2	0.8	0.5	0.2	2.4	1.6	1.1	0.7	0.4
CSFD 14S5-VV	5/8 ODF	3.6	2.4	1.6	1.0	0.5	3.3	2.2	1.4	0.9	0.4	4.4	2.9	2.0	1.2	0.6
CSFD 14S6-VV	3/4 ODF	4.9	3.2	2.2	1.4	0.7	4.5	2.9	1.9	1.2	0.6	5.9	3.9	2.7	1.7	0.9
CSFD 14S7-VV	7/8 ODF	5.2	3.4	2.3	1.5	0.8	4.8	3.1	2.0	1.3	0.7	6.3	4.1	2.8	1.9	1.0
CSFD 14S9-VV	1-1/8 ODF	7.0	4.6	3.1	2.0	1.0	6.5	4.2	2.7	1.7	0.8	8.5	5.6	3.8	2.5	1.3
SFD 13F3-VV	3/8 SAE	1.4	0.8	0.4	0.2	0.1	1.3	0.7	0.4	0.2	0.1	1.7	1.0	0.5	0.2	0.1
SFD 13S3-VV	3/8 ODF	2.2	1.3	0.8	0.5	0.2	2.0	1.2	0.7	0.4	0.2	2.7	1.6	1.0	0.6	0.3
SFD 13F4-VV	1/2 SAE	2.4	1.6	1.1	0.7	0.4	2.2	1.5	1.0	0.6	0.3	2.9	1.9	1.3	0.9	0.5
SFD 13S4-VV	1/2 ODF	3.5	2.3	1.6	1.0	0.6	3.2	2.1	1.4	0.9	0.5	4.2	2.8	2.0	1.2	0.8
SFD 13F5-VV	5/8 SAE	3.7	2.4	1.6	1.0	0.6	3.4	2.2	1.4	0.9	0.5	4.5	2.9	2.0	1.2	0.8
SFD 13S5-VV	5/8 ODF	4.9	3.2	2.2	1.4	0.8	4.5	2.9	1.9	1.2	0.7	5.9	3.9	2.7	1.7	1.0
SFD 13S6-VV	3/4 ODF	6.4	4.2	2.8	1.8	1.0	5.9	3.8	2.5	1.6	0.8	7.8	5.1	3.4	2.2	1.3
SFD 13S7-VV	7/8 ODF	7.2	4.6	3.0	1.9	1.0	6.7	4.2	2.7	1.7	0.8	8.7	5.6	3.7	2.4	1.3
SFD 27S6-VV	3/4 ODF	6.4	4.2	2.8	1.8	1.0	5.9	3.8	2.5	1.6	0.8	7.8	5.1	3.4	2.2	1.3
SFD 27S7-VV	7/8 ODF	7.5	4.8	3.2	2.0	1.1	7.0	4.4	2.8	1.7	0.9	9.1	5.8	3.9	2.5	1.4
SFD 27S9-VV	1-1/8 ODF	8.5	5.4	3.5	2.1	1.1	7.9	4.9	3.1	1.8	0.9	10.3	6.6	4.3	2.6	1.4
SFD 54S11-VV	1-3/8 ODF	7.3	4.6	3.0	1.8	1.0	6.8	4.2	2.7	1.6	0.8	8.9	5.6	3.7	2.2	1.3
SFD 54S13-VV	1-5/8 ODF	7.4	4.7	3.2	2.0	1.0	6.9	4.3	2.8	1.7	0.8	9.0	5.7	3.9	2.5	1.3

¹ All ratings in accordance with ARI Standard 730-04.

² Example: 1.0 tons x 3.5 = 3.5 kW

Hermetic Suction Line Filter Drier Flow Capacities

Description	Connections	Flow Capacity In Tons Refrigerant ¹ (For kW, Multiply Tons By 3.5) ²								
		R-502				R-404A/R-507				
		Evaporator Temperature (°F)								
		40	20	0	-20	40	20	0	-20	-40
Pressure Drop (PSI)										
3	2	1.5	1	3	2	1.5	1	0.5		
ASD 28S3-VV	3/8 ODF	2.2	1.1	0.7	0.5	2.1	1.1	0.7	0.5	0.3
ASD 28S4-VV	1/2 ODF	3.7	1.8	1.1	0.7	3.6	1.8	1.1	0.7	0.5
ASD 35F5-VV	5/8 SAE	4.2	2.1	1.3	0.9	4.1	2.1	1.3	0.9	0.6
ASD 35S5-VV	5/8 ODF	5.6	2.8	1.7	1.1	5.4	2.8	1.7	1.1	0.8
ASD 45S6-VV	3/4 ODF	6.6	3.7	2.5	1.5	6.4	3.7	2.5	1.6	1.0
ASD 45S7-VV	7/8 ODF	7.7	4.8	3.3	1.9	7.5	4.8	3.3	2.0	1.1
ASD 50S9-VV	1-1/8 ODF	11.0	6.9	4.6	2.7	11.0	6.9	4.6	2.8	1.4
ASD 75S11-VV	1-3/8 ODF	14.0	8.4	5.4	3.1	14.0	8.4	5.4	3.2	1.6
ASD 75S13-VV	1-5/8 ODF	15.0	8.9	5.7	3.3	15.0	8.9	5.7	3.4	1.7
ASF 28S3-VV	3/8 ODF	2.3	1.1	0.7	0.5	2.2	1.1	0.7	0.5	0.3
ASF 28S4-VV	1/2 ODF	3.9	2.0	1.2	0.8	3.8	2.0	1.2	0.8	0.6
ASF 35F5-VV	5/8 SAE	4.5	2.3	1.4	0.9	4.4	2.3	1.4	0.9	0.7
ASF 35S5-VV	5/8 ODF	6.3	3.2	2.0	1.4	6.1	3.2	2.0	1.4	1.0
ASF 45S6-VV	3/4 ODF	9.4	4.7	2.9	1.8	9.1	4.7	2.9	1.9	1.4
ASF 45S7-VV	7/8 ODF	10.0	6.3	4.5	2.7	9.8	6.3	4.5	2.8	1.5
ASF 50S9-VV	1-1/8 ODF	16.0	10.0	6.6	3.9	16.0	10.0	6.7	4.0	2.0
ASF 64S17-VV	2-1/8 ODF	36.0	23.0	15.0	9.5	35.0	23.0	15.0	9.8	5.2
ASF 75S11-VV	1-3/8 ODF	21.0	13.0	8.2	4.9	20.0	13.0	8.3	5.1	2.6
ASF 75S13-VV	1-5/8 ODF	22.0	13.0	8.3	5.0	21.0	13.0	8.4	5.2	2.7
ASK 16S5-VV-HH	5/8 ODF	3.3	1.9	1.2	0.8	3.2	1.9	1.2	0.8	0.3
ASK 16S6-VV-HH	3/4 ODF	4.0	2.4	1.6	0.9	3.9	2.4	1.6	0.9	0.5
ASK 16S7-VV-HH	7/8 ODF	4.4	2.6	1.7	1.0	4.3	2.6	1.7	1.0	0.6
ASK 30S6-VV-HH	3/4 ODF	5.2	3.2	2.2	1.2	5.0	3.2	2.2	1.2	0.7
ASK 30S7-VV-HH	7/8 ODF	5.8	3.5	2.3	1.4	5.6	3.5	2.3	1.4	0.7
ASK 30S9-VV-HH	1-1/8 ODF	6.2	3.7	2.4	1.4	6.0	3.7	2.4	1.5	0.7
CSFD 14S4-VV	1/2 ODF	1.3	0.8	0.5	0.3	1.3	0.8	0.5	0.3	0.2
CSFD 14S5-VV	5/8 ODF	2.7	1.7	1.1	0.7	2.6	1.7	1.1	0.7	0.3
CSFD 14S6-VV	3/4 ODF	3.7	2.3	1.5	0.9	3.6	2.3	1.5	0.9	0.5
CSFD 14S7-VV	7/8 ODF	4.0	2.4	1.6	1.0	3.9	2.4	1.6	1.0	0.5
CSFD 14S9-VV	1-1/8 ODF	5.1	3.1	2.0	1.3	4.9	3.1	2.0	1.3	0.7
SFD 13F3-VV	3/8 SAE	1.3	0.7	0.4	0.2	1.3	0.7	0.4	0.2	0.1
SFD 13S3-VV	3/8 ODF	2.0	1.1	0.7	0.4	1.9	1.1	0.7	0.4	0.2
SFD 13F4-VV	1/2 SAE	2.2	1.3	0.9	0.5	2.1	1.3	0.9	0.5	0.3
SFD 13S4-VV	1/2 ODF	3.1	1.9	1.3	0.8	3.0	1.9	1.3	0.8	0.4
SFD 13F5-VV	5/8 SAE	3.3	2.0	1.4	0.9	3.2	2.0	1.4	0.9	0.5
SFD 13S5-VV	5/8 ODF	4.3	2.7	1.8	1.1	4.2	2.7	1.8	1.1	0.6
SFD 13S6-VV	3/4 ODF	5.8	3.5	2.3	1.4	5.6	3.5	2.3	1.4	0.7
SFD 13S7-VV	7/8 ODF	6.5	3.9	2.6	1.4	6.3	3.9	2.6	1.5	0.8
SFD 27S6-VV	3/4 ODF	5.8	3.5	2.3	1.4	5.6	3.5	2.3	1.4	0.7
SFD 27S7-VV	7/8 ODF	6.7	4.1	2.7	1.5	6.5	4.1	2.7	1.6	0.8
SFD 27S9-VV	1-1/8 ODF	7.7	4.6	3.0	1.6	7.5	4.6	3.0	1.7	0.9
SFD 54S11-VV	1-3/8 ODF	6.6	3.9	2.5	1.4	6.4	3.9	2.5	1.5	0.7
SFD 54S13-VV	1-5/8 ODF	6.7	4.0	2.6	1.5	6.5	4.0	2.6	1.6	0.8

¹ All ratings in accordance with ARI Standard 730-04.

² Example: 1.0 tons x 3.5 = 3.5 kW

Take-Apart Suction Line Filter Drier Flow Capacities

Description	Connections	Filter Drier Cartridge	Flow Capacity in Tons Refrigerant ¹ (For kW, Multiply Tons By 3.5) ²							
			R-12				R-134a			
			Evaporator Temperature (°F)							
			40	20	0	-20	40	20	0	-20
			Pressure Drop (PSI)							
2	1.5	1	0.5	2	1.5	1	0.5			
ADKS 30013T	1-5/8 ODF	(3) F-100 Filter	24.0	17.0	12.0	7.0	25.0	17.0	11.0	6.2
ADKS 30017T	2-1/8 ODF	(3) F-100 Filter	42.0	31.0	20.0	12.0	43.0	30.0	19.0	11.0
ADKS 40017T	2-1/8 ODF	(4) F-100 Filter	44.0	32.0	21.0	12.0	45.0	31.0	20.0	11.0
ADKS 40021T	2-5/8 ODF	(4) F-100 Filter	66.0	48.0	32.0	19.0	68.0	47.0	30.0	17.0
ADKS 30013T	1-5/8 ODF	(3) 100 cu in Core	19.0	14.0	9.1	5.5	20.0	14.0	8.7	4.9
ADKS 30017T	2-1/8 ODF	(3) 100 cu in Core	30.0	22.0	15.0	8.7	31.0	22.0	14.0	7.7
ADKS 40017T	2-1/8 ODF	(4) 100 cu in Core	33.0	23.0	16.0	9.5	34.0	23.0	15.0	8.4
ADKS 40021T	2-5/8 ODF	(4) 100 cu in Core	48.0	35.0	23.0	14.0	49.0	34.0	22.0	12.0
BTAS-27 S-V	7/8 ODF	A2F Filter	4.7	3.4	2.2	1.2	4.8	3.3	2.1	1.1
BTAS-39 S-V	1-1/8 ODF	A3F Filter	7.1	5.1	3.4	1.9	7.3	5.0	3.2	1.7
BTAS-311 S-V	1-3/8 ODF	A3F Filter	7.9	5.6	3.7	2.1	8.1	5.5	3.5	1.9
BTAS-313 S-V	1-5/8 ODF	A3F Filter	13.0	8.9	5.9	3.4	13.0	8.8	5.6	3.0
BTAS-317 S-V	2-1/8 ODF	A3F Filter	15.0	11.0	7.2	4.2	16.0	11.0	6.9	3.7
BTAS-411 S-V	1-3/8 ODF	A4F Filter	17.0	12.0	8.0	4.5	17.0	12.0	7.4	4.0
BTAS-413 S-V	1-5/8 ODF	A4F Filter	20.0	15.0	10.0	5.5	21.0	14.0	9.1	4.9
BTAS-417 S-V	2-1/8 ODF	A4F Filter	28.0	20.0	13.0	7.5	29.0	20.0	12.0	6.7
BTAS-421 S-V	2-5/8 ODF	A4F Filter	34.0	24.0	16.0	9.1	35.0	24.0	15.0	8.1
BTAS-517 S-V	2-1/8 ODF	A5F Filter	33.0	24.0	16.0	9.1	34.0	24.0	15.0	8.1
BTAS-521 S-V	2-5/8 ODF	A5F Filter	44.0	32.0	21.0	12.0	45.0	31.0	20.0	11.0
BTAS-525 S-V	3-1/8 ODF	A5F Filter	54.0	39.0	25.0	15.0	56.0	38.0	24.0	13.0
BTAS-25 S-V	5/8 ODF	A2F-D Filter Drier	2.4	1.7	1.2	0.7	2.5	1.7	1.1	0.6
BTAS-27 S-V	7/8 ODF	A2F-D Filter Drier	4.0	2.8	1.9	1.1	4.1	2.8	1.8	1.0
BTAS-39 S-V	1-1/8 ODF	A3F-D Filter Drier	5.2	3.7	2.4	1.4	5.3	3.6	2.3	1.2
BTAS-311 S-V	1-3/8 ODF	A3F-D Filter Drier	7.2	5.2	3.4	1.9	7.4	5.1	3.2	1.7
BTAS-313 S-V	1-5/8 ODF	A3F-D Filter Drier	10.0	7.4	4.8	2.8	11.0	7.3	4.6	2.5
BTAS-317 S-V	2-1/8 ODF	A3F-D Filter Drier	12.0	8.5	5.7	3.3	12.0	8.4	5.4	2.9
BTAS-411 S-V	1-3/8 ODF	A4F-D Filter Drier	15.0	11.0	7.0	4.1	15.0	11.0	6.7	3.6
BTAS-413 S-V	1-5/8 ODF	A4F-D Filter Drier	15.0	11.0	7.2	4.2	16.0	11.0	6.9	3.7
BTAS-417 S-V	2-1/8 ODF	A4F-D Filter Drier	22.0	16.0	11.0	6.1	23.0	16.0	10.0	5.4
BTAS-421 S-V	2-5/8 ODF	A4F-D Filter Drier	23.0	17.0	11.0	6.3	24.0	16.0	10.0	5.6
BTAS-517 S-V	2-1/8 ODF	A5F-D Filter Drier	27.0	19.0	13.0	7.2	28.0	19.0	12.0	6.4
BTAS-521 S-V	2-5/8 ODF	A5F-D Filter Drier	32.0	23.0	15.0	8.8	33.0	23.0	14.0	7.8
BTAS-525 S-V	3-1/8 ODF	A5F-D Filter Drier	38.0	27.0	18.0	10.0	39.0	27.0	17.0	9.2
STAS-489 S-V	1-1/8 ODF	(1) F-48 Filter	13.0	8.0	5.0	2.0	13.0	8.0	5.0	2.0
STAS-4811 S-V	1-3/8 ODF	(1) F-48 Filter	15.0	10.0	6.0	3.0	15.0	10.0	6.0	3.0
STAS-4813 S-V	1-5/8 ODF	(1) F-48 Filter	19.0	12.0	7.0	5.0	20.0	12.0	7.0	4.0
STAS-4817 S-V	2-1/8 ODF	(1) F-48 Filter	24.0	15.0	11.0	6.0	25.0	15.0	10.0	5.0
STAS-4821 S-V	2-5/8 ODF	(1) F-48 Filter	29.0	20.0	14.0	7.0	30.0	20.0	13.0	6.0
STAS-9617 S-V	2-1/8 ODF	(2) F-48 Filter	27.0	18.0	11.0	6.0	28.0	18.0	10.0	5.0
STAS-9621 S-V	2-5/8 ODF	(2) F-48 Filter	37.0	25.0	16.0	8.0	38.0	25.0	15.0	7.0
STAS-9625 S-V	3-1/8 ODF	(2) F-48 Filter	65.0	52.0	38.0	21.0	79.0	61.0	43.0	20.0
STAS-489 S-V	1-1/8 ODF	(1) 48 cu in Core	8.0	6.0	4.0	1.0	8.0	6.0	4.0	1.0
STAS-4811 S-V	1-3/8 ODF	(1) 48 cu in Core	10.0	7.0	4.0	2.0	10.0	7.0	4.0	2.0
STAS-4813 S-V	1-5/8 ODF	(1) 48 cu in Core	13.0	8.0	5.0	3.0	13.0	8.0	5.0	3.0
STAS-4817 S-V	2-1/8 ODF	(1) 48 cu in Core	17.0	10.0	7.0	5.0	17.0	10.0	7.0	4.0
STAS-4821 S-V	2-5/8 ODF	(1) 48 cu in Core	19.0	13.0	8.0	5.0	20.0	13.0	8.0	4.0
STAS-9617 S-V	2-1/8 ODF	(2) 48 cu in Core	18.0	12.0	6.0	5.0	18.0	12.0	6.0	4.0
STAS-9621 S-V	2-5/8 ODF	(2) 48 cu in Core	24.0	17.0	11.0	6.0	25.0	17.0	10.0	5.0
STAS-9625 S-V	3-1/8 ODF	(2) 48 cu in Core	24.0	19.0	14.0	7.4	29.0	23.0	16.0	7.0

¹ All ratings in accordance with ARI Standard 730-04.

² Example: 1.0 tons x 3.5 = 3.5 kW

Take-Apart Suction Line Filter Drier Flow Capacities

Description	Connections	Filter Drier Cartridge	Flow Capacity in Tons Refrigerant ¹ (For kW, Multiply Tons By 3.5) ²														
			R-22					R-407C					R-410A				
			Evaporator Temperature (°F)														
			40	20	0	-20	-40	40	20	0	-20	-40	40	20	0	-20	-40
			Pressure Drop (PSI)														
3	2	1.5	1	0.5	3	2	1.5	1	0.5	3	2	1.5	1	0.5			
ADKS 30013T	1-5/8 ODF	(3) F-100 Filter	45.0	30.0	20.0	13.0	7.0	41.7	27.3	17.7	11.3	5.8	-	-	-	-	-
ADKS 30017T	2-1/8 ODF	(3) F-100 Filter	77.0	50.0	35.0	22.0	12.0	71.4	45.5	31.0	19.2	10.0	-	-	-	-	-
ADKS 40017T	2-1/8 ODF	(4) F-100 Filter	80.0	53.0	37.0	23.0	13.0	74.2	48.2	32.8	20.0	10.8	-	-	-	-	-
ADKS 40021T	2-5/8 ODF	(4) F-100 Filter	122.0	80.0	55.0	34.0	19.0	113.1	72.7	48.7	29.6	15.8	-	-	-	-	-
ADKS 30013T	1-5/8 ODF	(3) 100 cu in Core	35.0	23.0	16.0	10.0	5.5	32.4	20.9	14.2	8.7	4.6	-	-	-	-	-
ADKS 30017T	2-1/8 ODF	(3) 100 cu in Core	56.0	37.0	25.0	16.0	8.8	51.9	33.6	22.1	13.9	7.3	-	-	-	-	-
ADKS 40017T	2-1/8 ODF	(4) 100 cu in Core	61.0	40.0	27.0	17.0	9.5	56.5	36.4	23.9	14.8	7.9	-	-	-	-	-
ADKS 40021T	2-5/8 ODF	(4) 100 cu in Core	88.0	58.0	40.0	25.0	14.0	81.6	52.7	35.4	21.8	11.6	-	-	-	-	-
BTAS-27 S-V	7/8 ODF	A2F Filter	8.8	5.7	3.9	2.5	1.3	8.2	5.2	3.5	2.2	1.1	-	-	-	-	-
BTAS-39 S-V	1-1/8 ODF	A3F Filter	14.0	8.8	5.9	3.7	2.0	13.0	8.0	5.2	3.2	1.7	-	-	-	-	-
BTAS-311 S-V	1-3/8 ODF	A3F Filter	15.0	10.0	6.6	4.1	2.2	13.9	9.1	5.8	3.6	1.8	-	-	-	-	-
BTAS-313 S-V	1-5/8 ODF	A3F Filter	24.0	16.0	11.0	6.6	3.5	22.2	14.5	9.7	5.8	2.9	-	-	-	-	-
BTAS-317 S-V	2-1/8 ODF	A3F Filter	29.0	19.0	13.0	8.1	4.3	26.9	17.3	11.5	7.1	3.6	-	-	-	-	-
BTAS-411 S-V	1-3/8 ODF	A4F Filter	31.0	20.0	14.0	8.7	4.6	28.7	18.2	12.4	7.6	3.8	-	-	-	-	-
BTAS-413 S-V	1-5/8 ODF	A4F Filter	38.0	25.0	17.0	11.0	5.7	35.2	22.7	15.1	9.6	4.7	-	-	-	-	-
BTAS-417 S-V	2-1/8 ODF	A4F Filter	53.0	34.0	23.0	15.0	7.8	49.1	30.9	20.4	13.1	6.5	-	-	-	-	-
BTAS-421 S-V	2-5/8 ODF	A4F Filter	64.0	42.0	29.0	18.0	10.0	59.3	38.2	25.7	15.7	8.3	-	-	-	-	-
BTAS-517 S-V	2-1/8 ODF	A5F Filter	63.0	41.0	28.0	18.0	9.4	58.4	37.3	24.8	15.7	7.8	-	-	-	-	-
BTAS-521 S-V	2-5/8 ODF	A5F Filter	84.0	54.0	37.0	23.0	12.0	77.9	49.1	32.8	20.0	10.0	-	-	-	-	-
BTAS-525 S-V	3-1/8 ODF	A5F Filter	103.0	67.0	46.0	29.0	15.0	95.5	60.9	40.7	25.3	12.5	-	-	-	-	-
BTAS-25 S-V	5/8 ODF	A2F-D Filter Drier	4.6	3.0	2.0	1.3	0.7	4.3	2.7	1.8	1.1	0.6	-	-	-	-	-
BTAS-27 S-V	7/8 ODF	A2F-D Filter Drier	7.5	4.9	3.3	2.1	1.1	7.0	4.5	2.9	1.8	0.9	-	-	-	-	-
BTAS-39 S-V	1-1/8 ODF	A3F-D Filter Drier	10.0	6.3	4.3	2.7	1.4	9.3	5.7	3.8	2.4	1.2	-	-	-	-	-
BTAS-311 S-V	1-3/8 ODF	A3F-D Filter Drier	14.0	8.9	6.0	3.8	2.0	13.0	8.1	5.3	3.3	1.7	-	-	-	-	-
BTAS-313 S-V	1-5/8 ODF	A3F-D Filter Drier	20.0	13.0	8.6	5.4	2.9	18.5	11.8	7.6	4.7	2.4	-	-	-	-	-
BTAS-317 S-V	2-1/8 ODF	A3F-D Filter Drier	23.0	15.0	10.0	6.3	3.4	21.3	13.6	8.9	5.5	2.8	-	-	-	-	-
BTAS-411 S-V	1-3/8 ODF	A4F-D Filter Drier	28.0	18.0	13.0	7.8	4.2	26.0	16.4	11.5	6.8	3.5	-	-	-	-	-
BTAS-413 S-V	1-5/8 ODF	A4F-D Filter Drier	29.0	19.0	13.0	8.1	4.3	26.9	17.3	11.5	7.1	3.6	-	-	-	-	-
BTAS-417 S-V	2-1/8 ODF	A4F-D Filter Drier	43.0	28.0	19.0	12.0	6.3	39.9	25.5	16.8	10.5	5.2	-	-	-	-	-
BTAS-421 S-V	2-5/8 ODF	A4F-D Filter Drier	44.0	29.0	19.0	12.0	6.5	40.8	26.4	16.8	10.5	5.4	-	-	-	-	-
BTAS-517 S-V	2-1/8 ODF	A5F-D Filter Drier	51.0	33.0	22.0	14.0	7.5	47.3	30.0	19.5	12.2	6.2	-	-	-	-	-
BTAS-521 S-V	2-5/8 ODF	A5F-D Filter Drier	61.0	40.0	27.0	17.0	9.0	56.5	36.4	23.9	14.8	7.5	-	-	-	-	-
BTAS-525 S-V	3-1/8 ODF	A5F-D Filter Drier	72.0	47.0	32.0	20.0	11.0	66.7	42.7	28.3	17.4	9.2	-	-	-	-	-
STAS-489 S-V	1-1/8 ODF	(1) F-48 Filter	22.0	14.0	10.0	6.0	2.0	20	13	9	5	2	27.0	17.0	12.0	7.0	3.0
STAS-4811 S-V	1-3/8 ODF	(1) F-48 Filter	28.0	17.0	12.0	7.0	3.0	26	15	11	6	2	34.0	21.0	15.0	9.0	4.0
STAS-4813 S-V	1-5/8 ODF	(1) F-48 Filter	35.0	20.0	15.0	8.0	4.0	32	18	13	7	3	42.0	24.0	18.0	10.0	5.0
STAS-4817 S-V	2-1/8 ODF	(1) F-48 Filter	47.0	30.0	20.0	10.0	5.0	44	27	18	9	4	57.0	36.0	25.0	12.0	6.0
STAS-4821 S-V	2-5/8 ODF	(1) F-48 Filter	60.0	40.0	25.0	15.0	7.0	56	36	22	13	6	73.0	49.0	31.0	19.0	9.0
STAS-9617 S-V	2-1/8 ODF	(2) F-48 Filter	50.0	30.0	20.0	12.0	6.0	46	27	18	10	5	61.0	36.0	25.0	15.0	8.0
STAS-9621 S-V	2-5/8 ODF	(2) F-48 Filter	70.0	43.0	28.0	17.0	8.0	65	39	25	15	7	85.0	52.0	34.0	21.0	10.0
STAS-9625 S-V	3-1/8 ODF	(2) F-48 Filter	101.0	62.0	40.0	24.0	11.0	94	56	36	21	10	122.0	73.0	48.0	29.0	14.0
STAS-489 S-V	1-1/8 ODF	(1) 48 cu in Core	15.0	9.0	7.0	4.0	1.0	14	8	6	3	1	18.0	11.0	9.0	5.0	1.0
STAS-4811 S-V	1-3/8 ODF	(1) 48 cu in Core	18.0	11.0	8.0	5.0	2.0	17	10	7	4	2	22.0	13.0	10.0	6.0	3.0
STAS-4813 S-V	1-5/8 ODF	(1) 48 cu in Core	23.0	13.0	10.0	6.0	3.0	21	12	9	5	2	28.0	16.0	12.0	7.0	4.0
STAS-4817 S-V	2-1/8 ODF	(1) 48 cu in Core	31.0	20.0	13.0	7.0	3.0	29	18	12	6	2	38.0	24.0	16.0	9.0	4.0
STAS-4821 S-V	2-5/8 ODF	(1) 48 cu in Core	40.0	27.0	17.0	10.0	5.0	37	25	15	9	4	49.0	33.0	21.0	12.0	6.0
STAS-9617 S-V	2-1/8 ODF	(2) 48 cu in Core	33.0	20.0	13.0	8.0	4.0	31	18	12	7	3	40.0	24.0	16.0	10.0	5.0
STAS-9621 S-V	2-5/8 ODF	(2) 48 cu in Core	47.0	28.0	18.0	11.0	6.0	44	25	16	10	5	57.0	34.0	22.0	14.0	8.0
STAS-9625 S-V	3-1/8 ODF	(2) 48 cu in Core	38.0	30.0	24.0	17.0	7.6	35	27	24	15	6	46.0	36.0	29.0	21.0	10.0

¹ All ratings in accordance with ARI Standard 730-04.

² Example: 1.0 tons x 3.5 = 3.5 kW

Take-Apart Suction Line Filter Drier Flow Capacities

Description	Connections	Filter Drier Cartridge	Flow Capacity In Tons Refrigerant ¹ (For kW, Multiply Tons By 3.5) ²									
			R-502					R-404A/R-507				
			Evaporator Temperature (°F)									
			40	20	0	-20	-40	40	20	0	-20	-40
			Pressure Drop (PSI)									
3	2	1.5	1	0.5	3	2	1.5	1	0.5			
ADKS 30013T	1-5/8 ODF	(3) F-100 Filter	38.0	24.0	16.0	9.9	5.2	37.0	24.0	16.0	10.0	5.5
ADKS 30017T	2-1/8 ODF	(3) F-100 Filter	64.0	40.0	27.0	17.0	8.9	62.0	40.0	27.0	18.0	9.4
ADKS 40017T	2-1/8 ODF	(4) F-100 Filter	68.0	43.0	28.0	17.0	9.2	66.0	43.0	29.0	18.0	9.8
ADKS 40021T	2-5/8 ODF	(4) F-100 Filter	102.0	64.0	43.0	27.0	14.0	99.0	64.0	43.0	28.0	15.0
ADKS 30013T	1-5/8 ODF	(3) 100 cu in Core	30.0	19.0	12.0	7.7	4.1	29.0	19.0	13.0	8.0	4.3
ADKS 30017T	2-1/8 ODF	(3) 100 cu in Core	47.0	30.0	20.0	12.0	6.4	46.0	30.0	20.0	13.0	6.8
ADKS 40017T	2-1/8 ODF	(4) 100 cu in Core	51.0	32.0	22.0	13.0	7.0	49.0	32.0	22.0	14.0	7.4
ADKS 40021T	2-5/8 ODF	(4) 100 cu in Core	74.0	47.0	31.0	19.0	10.0	72.0	47.0	32.0	20.0	11.0
BTAS-27 S-V	7/8 ODF	A2F Filter	7.4	4.6	3.1	1.8	0.9	7.2	4.6	3.1	1.9	1.0
BTAS-39 S-V	1-1/8 ODF	A3F Filter	11.0	7.0	4.7	2.8	1.4	11.0	7.0	4.7	2.9	1.5
BTAS-311 S-V	1-3/8 ODF	A3F Filter	12.0	7.8	5.2	3.1	1.6	12.0	7.8	5.2	3.2	1.7
BTAS-313 S-V	1-5/8 ODF	A3F Filter	20.0	12.0	8.2	5.0	2.5	19.0	12.0	8.3	5.2	2.7
BTAS-317 S-V	2-1/8 ODF	A3F Filter	25.0	15.0	10.0	6.1	3.1	24.0	15.0	10.0	6.3	3.3
BTAS-411 S-V	1-3/8 ODF	A4F Filter	27.0	16.0	11.0	6.6	3.4	26.0	16.0	11.0	6.8	3.6
BTAS-413 S-V	1-5/8 ODF	A4F Filter	32.0	20.0	13.0	8.1	4.1	31.0	20.0	14.0	8.4	4.4
BTAS-417 S-V	2-1/8 ODF	A4F Filter	44.0	28.0	18.0	11.0	5.7	43.0	28.0	19.0	12.0	6.0
BTAS-421 S-V	2-5/8 ODF	A4F Filter	54.0	34.0	23.0	14.0	6.9	52.0	34.0	23.0	14.0	7.3
BTAS-517 S-V	2-1/8 ODF	A5F Filter	54.0	33.0	22.0	13.0	6.8	52.0	33.0	22.0	14.0	7.2
BTAS-521 S-V	2-5/8 ODF	A5F Filter	70.0	44.0	29.0	18.0	9.0	68.0	44.0	29.0	18.0	9.6
BTAS-525 S-V	3-1/8 ODF	A5F Filter	87.0	54.0	36.0	22.0	11.0	84.0	54.0	36.0	23.0	12.0
BTAS-25 S-V	5/8 ODF	A2F-D Filter Drier	3.9	2.4	1.6	1.0	0.5	3.8	2.4	1.6	1.0	0.5
BTAS-27 S-V	7/8 ODF	A2F-D Filter Drier	6.3	3.9	2.6	1.5	0.8	6.1	3.9	2.6	1.6	0.9
BTAS-39 S-V	1-1/8 ODF	A3F-D Filter Drier	8.1	5.1	3.4	2.0	1.0	7.9	5.1	3.4	2.1	1.1
BTAS-311 S-V	1-3/8 ODF	A3F-D Filter Drier	11.0	7.1	4.8	2.9	1.5	11.0	7.1	4.8	3.0	1.6
BTAS-313 S-V	1-5/8 ODF	A3F-D Filter Drier	16.0	10.0	6.7	4.1	2.1	16.0	10.0	6.8	4.2	2.2
BTAS-317 S-V	2-1/8 ODF	A3F-D Filter Drier	19.0	12.0	7.9	4.8	2.4	19.0	12.0	8.0	5.0	2.6
BTAS-411 S-V	1-3/8 ODF	A4F-D Filter Drier	24.0	15.0	10.0	5.9	3.0	23.0	15.0	10.0	6.1	3.2
BTAS-413 S-V	1-5/8 ODF	A4F-D Filter Drier	25.0	15.0	10.0	6.1	3.1	24.0	15.0	10.0	6.3	3.3
BTAS-417 S-V	2-1/8 ODF	A4F-D Filter Drier	36.0	22.0	15.0	9.0	4.6	35.0	22.0	15.0	9.3	4.9
BTAS-421 S-V	2-5/8 ODF	A4F-D Filter Drier	37.0	23.0	15.0	9.2	4.7	36.0	23.0	15.0	10.0	5.0
BTAS-517 S-V	2-1/8 ODF	A5F-D Filter Drier	42.0	27.0	18.0	11.0	4.7	41.0	27.0	18.0	11.0	5.0
BTAS-521 S-V	2-5/8 ODF	A5F-D Filter Drier	52.0	32.0	22.0	13.0	6.6	50.0	32.0	22.0	13.0	7.0
BTAS-525 S-V	3-1/8 ODF	A5F-D Filter Drier	61.0	38.0	25.0	15.0	7.8	59.0	38.0	25.0	16.0	8.3
STAS-489 S-V	1-1/8 ODF	(1) F-48 Filter	21.0	12.0	8.0	5.0	3.0	20.0	12.0	8.0	5.0	3.0
STAS-4811 S-V	1-3/8 ODF	(1) F-48 Filter	15.0	15.0	10.0	6.0	4.0	15.0	15.0	10.0	6.0	4.0
STAS-4813 S-V	1-5/8 ODF	(1) F-48 Filter	31.0	18.0	11.0	7.0	5.0	30.0	18.0	11.0	7.0	5.0
STAS-4817 S-V	2-1/8 ODF	(1) F-48 Filter	41.0	25.0	15.0	9.0	7.0	40.0	25.0	15.0	9.0	7.0
STAS-4821 S-V	2-5/8 ODF	(1) F-48 Filter	57.0	30.0	20.0	12.0	8.0	55.0	30.0	20.0	12.0	8.0
STAS-9617 S-V	2-1/8 ODF	(2) F-48 Filter	41.0	25.0	15.0	10.0	7.0	40.0	25.0	15.0	10.0	7.0
STAS-9621 S-V	2-5/8 ODF	(2) F-48 Filter	62.0	35.0	25.0	14.0	9.0	60.0	35.0	25.0	15.0	10.0
STAS-9625 S-V	3-1/8 ODF	(2) F-48 Filter	73.0	59.0	47.0	34.0	19.0	80.0	63.0	50.0	35.0	18.0
STAS-489 S-V	1-1/8 ODF	(1) 48 cu in Core	13.0	8.0	6.0	4.0	2.0	13.0	8.0	6.0	4.0	2.0
STAS-4811 S-V	1-3/8 ODF	(1) 48 cu in Core	18.0	10.0	6.0	4.0	3.0	17.0	10.0	6.0	4.0	3.0
STAS-4813 S-V	1-5/8 ODF	(1) 48 cu in Core	21.0	12.0	7.0	5.0	4.0	20.0	12.0	7.0	5.0	4.0
STAS-4817 S-V	2-1/8 ODF	(1) 48 cu in Core	28.0	17.0	10.0	6.0	5.0	27.0	17.0	10.0	6.0	5.0
STAS-4821 S-V	2-5/8 ODF	(1) 48 cu in Core	38.0	20.0	13.0	8.0	6.0	37.0	20.0	13.0	8.0	6.0
STAS-9617 S-V	2-1/8 ODF	(2) 48 cu in Core	28.0	17.0	11.0	7.0	5.0	27.0	17.0	11.0	7.0	5.0
STAS-9621 S-V	2-5/8 ODF	(2) 48 cu in Core	41.0	23.0	17.0	10.0	7.0	40.0	23.0	17.0	10.0	7.0
STAS-9625 S-V	3-1/8 ODF	(2) 48 cu in Core	27.0	22.0	18.0	13.0	6.7	30.0	24.0	18.0	13.0	6.5

¹ All ratings in accordance with ARI Standard 730-04.

² Example: 1.0 tons x 3.5 = 3.5 kW

A-AS Suction Accumulator Capacity Tables in Tons of Refrigeration

DESCRIPTION	R-134a					R-404A/R-507				
	-40°F	-20°F	0°F	+20°F	+40°F	-40°F	-20°F	0°F	+20°F	+40°F
A-AS 3 84	0.20	0.30	0.60	0.80	1.20	0.20	0.40	0.80	1.00	1.30
A-AS 3 105	0.30	0.50	0.80	1.20	1.70	0.40	0.60	1.20	1.60	2.00
A-AS 3 125	0.30	0.50	0.80	1.20	1.70	0.40	0.60	1.20	1.60	2.00
A-AS 3 126	0.40	0.60	1.00	1.60	2.30	0.40	0.70	1.50	2.00	2.60
A-AS 3 145	0.30	0.50	0.80	1.20	1.70	0.40	0.60	1.20	1.60	2.00
A-AS 3 146	0.40	0.60	1.00	1.60	2.30	0.40	0.70	1.50	2.00	2.60
A-AS 4 64	0.20	0.30	0.60	0.80	1.20	0.20	0.40	0.80	1.00	1.30
A-AS 4 65	0.30	0.50	0.80	1.20	1.70	0.40	0.60	1.20	1.60	2.00
A-AS 4 105	0.30	0.50	0.80	1.20	1.70	0.40	0.60	1.20	1.60	2.00
A-AS 4 106	0.40	0.60	1.00	1.60	2.30	0.40	0.70	1.50	2.00	2.60
A-AS 5 96	0.40	0.60	1.00	1.60	2.30	0.40	0.70	1.50	2.00	2.60
A-AS 5 97	0.70	1.10	1.80	2.80	4.00	0.80	1.30	2.70	3.60	4.60
A-AS 5 126	0.40	0.60	1.00	1.60	2.30	0.40	0.70	1.50	2.00	2.60
A-AS 5 127	0.70	1.10	1.80	2.80	4.00	0.80	1.30	2.70	3.60	4.60
A-AS 5 137	0.70	1.10	1.80	2.80	4.00	0.80	1.30	2.70	3.60	4.60
A-AS 5 139	1.30	2.00	3.10	5.00	7.20	1.40	2.10	4.40	5.90	7.60
A-AS 5 179	1.90	3.00	3.10	5.00	7.20	1.40	2.10	4.40	5.90	7.60
A-AS 5 1711	1.90	3.00	4.60	7.30	10.70	2.20	3.40	7.20	9.60	12.20
A-AS 6 117	0.70	1.10	1.80	2.80	4.00	0.80	1.30	2.70	3.60	4.60
A-AS 6 137	0.70	1.10	1.80	2.80	4.00	0.80	1.30	2.70	3.60	4.60
A-AS 6 139	1.30	2.00	3.10	5.00	7.20	1.40	2.10	4.40	5.90	7.60
A-AS 6 1411	1.90	3.00	4.60	7.30	10.70	2.20	3.40	7.20	9.60	12.20
A-AS 6 1713	3.00	4.80	7.30	11.70	17.00	3.30	5.10	10.70	14.20	18.20
A-AS 6 2013	3.00	4.80	7.30	11.70	17.00	3.30	5.10	10.70	14.20	18.20
A-AS 6 2513	3.00	4.80	7.30	11.70	17.00	3.30	5.10	10.70	14.20	18.20

DESCRIPTION	R-22					R-502				
	-40°F	-20°F	0°F	+20°F	+40°F	-40°F	-20°F	0°F	+20°F	+40°F
A-AS 3 84	0.40	0.60	0.90	1.40	2.00	0.30	0.50	0.80	1.30	1.80
A-AS 3 105	0.50	0.80	1.40	2.10	3.00	0.50	0.80	1.20	1.90	2.70
A-AS 3 125	0.50	0.80	1.40	2.10	3.00	0.50	0.80	1.20	1.90	2.70
A-AS 3 126	0.72	1.10	1.80	2.80	4.00	0.60	1.00	1.60	2.50	3.50
A-AS 3 145	0.50	0.80	1.40	2.10	3.00	0.60	0.80	1.20	1.90	2.70
A-AS 3 146	0.72	1.10	1.80	2.80	4.00	0.60	1.00	1.60	2.50	3.50
A-AS 4 64	0.40	0.60	0.90	1.40	2.00	0.30	0.50	0.80	1.30	1.80
A-AS 4 65	0.50	0.80	1.40	2.10	3.00	0.50	0.80	1.20	1.90	2.70
A-AS 4 105	0.50	0.80	1.40	2.10	3.00	0.50	0.80	1.20	1.90	2.70
A-AS 4 106	0.72	1.10	1.80	2.80	4.00	0.60	1.00	1.60	2.50	3.50
A-AS 5 96	0.72	1.10	1.80	2.80	4.00	0.60	1.00	1.60	2.50	3.50
A-AS 5 97	1.30	2.00	3.30	5.10	7.30	1.10	1.70	2.80	4.30	6.20
A-AS 5 126	0.72	1.10	1.80	2.80	4.00	0.60	1.00	1.60	2.50	3.50
A-AS 5 127	1.30	2.00	3.30	5.10	7.30	1.10	1.70	2.80	4.30	6.20
A-AS 5 137	1.30	2.00	3.30	5.10	7.30	1.10	1.70	2.80	4.30	6.20
A-AS 5 139	2.10	3.30	5.30	8.30	11.80	1.90	2.90	4.60	7.10	10.20
A-AS 5 179	2.10	3.30	5.30	8.30	11.80	1.90	2.90	4.60	7.10	10.20
A-AS 5 1711	3.40	5.30	8.50	13.20	18.80	3.00	4.60	7.40	11.60	16.50
A-AS 6 117	1.30	2.00	3.30	5.10	7.30	1.10	1.70	2.80	4.30	6.20
A-AS 6 137	1.30	2.00	3.30	5.10	7.30	1.10	1.70	2.80	4.30	6.20
A-AS 6 139	2.10	3.30	5.30	8.30	11.80	1.90	2.90	4.60	7.10	10.20
A-AS 6 1411	3.40	5.30	8.50	13.20	18.80	3.00	4.60	7.40	11.60	16.50
A-AS 6 1713	5.10	8.00	12.80	20.00	28.50	4.40	6.90	11.00	17.20	24.50
A-AS 6 2013	5.10	8.00	12.80	20.00	28.50	4.40	6.90	11.00	17.20	24.50
A-AS 6 2513			12.80	20.80	28.50	4.40	6.90	11.00	17.20	24.50

The maximum capacity in tons recommended is based on a pressure drop through the accumulator equivalent to 1.0°F.

Note: 1) The minimum system capacity in tons must be no less than 15% of the stated capacity in order to ensure a positive return of oil.
 2) All of the data is based on tons of refrigeration and is not related to horsepower.
 3) Minimum evaporator temperature of -40°F. Minimum temperature of the suction gas through the accumulator is 12°F.

DCFm Charge Calculations

How to Calculate DCFm Charge

Example:
 System: 10 tons, R-22
 Evaporator Temperature: -32C/-27F
 Condensing Temperature: 46C/115F

In the DCFm graphs below for R-22, follow the -32C/-27F evaporator temperature line to the intersection with the 46C/115F condensing temperature line. Extend a horizontal line from this point into the DCFm / ton line. Then, multiply the DCFm / ton factor by the capacity in tons provided to calculate the total compressor charge (DCFm).

Example:
 $0.72 \frac{\text{DCFm}}{\text{ton}} \times 10 \text{ ton} = 7.2 \text{ CFM}$
 Oil Separator selected: AF-58889

DCFm = Cubic feet per minute

DCFm - R22

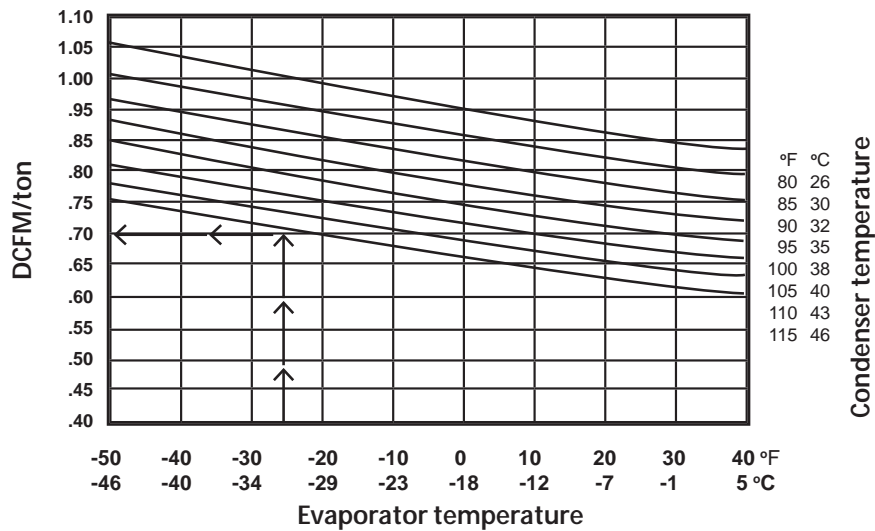

DCFm - R134a

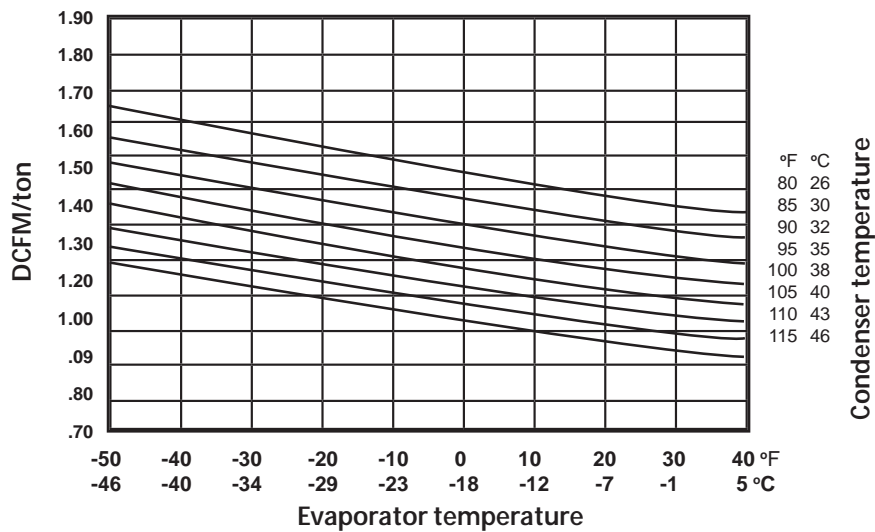

DCFm Charge Calculations

- Thermal Expansion Valves
- TXV Extended Capacity Tables
- EX Valves and Controls
- Solenoid Valves and Coils
- Solenoid Capacity Tables
- Industrial Solenoid Valves
- Shut Off Valves
- System Protectors
- System Protectors Capacity Tables
- Oil Controls
- Temperature Pressure Controls

DCFm - R404A/R507

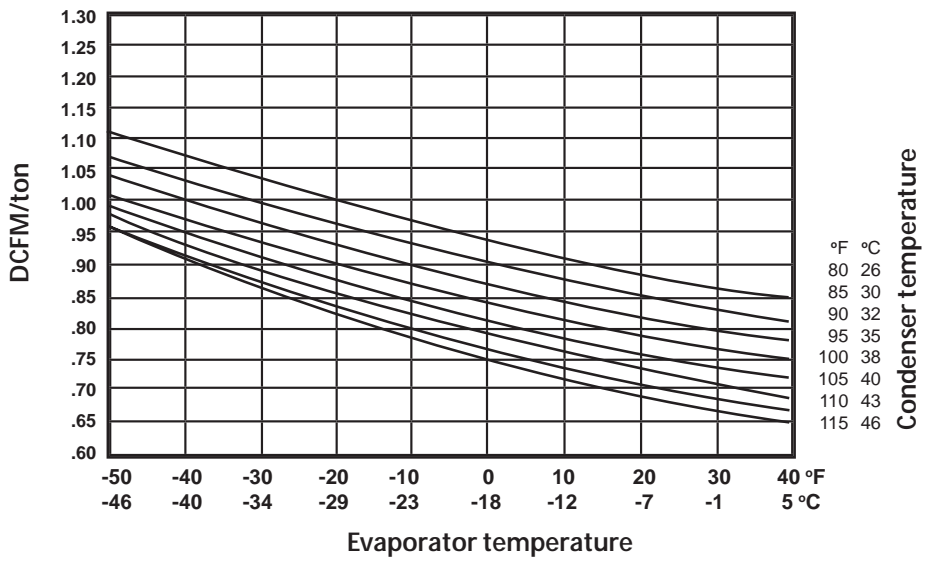

DCFm - R407A

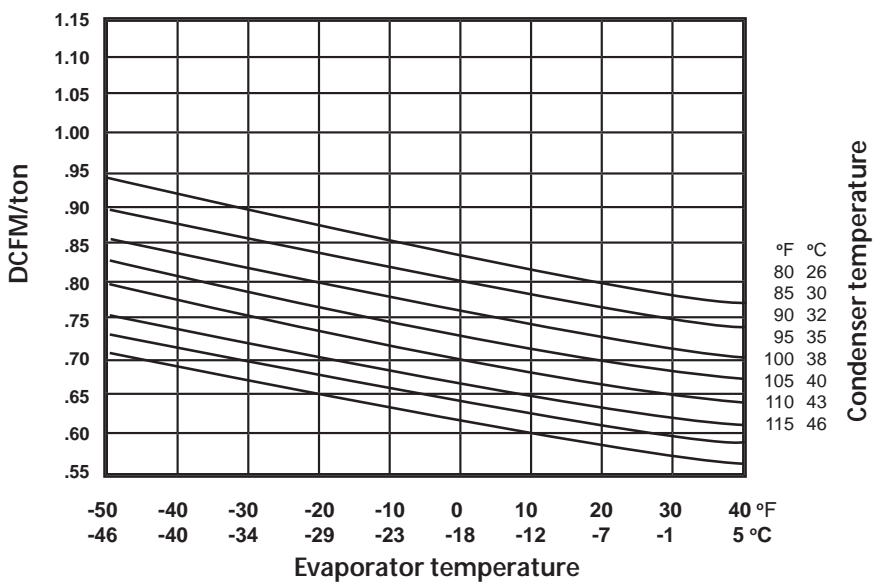

High Efficiency Centrifugal Oil Separator

The High Efficiency Centrifugal Oil Separator is used in ultra-low temperature systems with long refrigerant lines or inherent oil return problems. It is also used on multiple compressor racks for supermarkets and air conditioning systems for use with CFCs, HCFCs, HFCs, and their lubricants. Suitable for use with R-410A.



R-410A

Features

- Internal oil collection screen
- Hermetic welded or accessible bolted flange construction
- Corrosion resistant epoxy powder paint
- High efficiency (99%) centrifugal separation
- R-410A pressure rated

Nomenclature example: A-FC 8241717H

A	F	C	8	24	17	17	H
Series	F = Flanged W = Welded	Centrifugal	Diameter (in)	Length (in)	Inlet Connection in 1/8"	Outlet Connection in 1/8"	5" Legs Standard H = 10" Legs

Ordering Information

PCN	Description	Solder Connection Size	Dimensions			
			A	B	C	D
065895*	A-WC 41777	7/8	17.01	2.95	4.00	2.95
065896*	A-WC 41999	1 1/8	19.02	3.07		
066094*	A-WC 6181111	1 3/8	18.26	4.05	6.0	
066095*	A-WC 6181313	1 5/8		4.63		
066096*	A-WC 6181717	2 1/8		4.76		
065930	A-FC 6221111	1 3/8	17.00	3.94	6.0	5.00
065931	A-FC 6221111H			10.00		
065362	A-FC 6221313	1 5/8	17.13	4.53	6.0	5.00
065932	A-FC 6221313H			10.00		
065933	A-FC 6221717	2 1/8	17.13	4.65	6.0	5.00
065934	A-FC 6221717H			10.00		
065276	A-FC 8241717	2 5/8	22.10	6.83	8.0	5.00
065935	A-FC 8241717H			10.00		
065936	A-FC 10272121	3 1/8	25.10	6.11	10.00	5.00
065937	A-FC 10272121H			10.00		
065938	A-FC 12302525H	3 1/8	25.10	7.05	12.00	10.00

Specifications

- Maximum working pressure: 450 psi - flanged models*
600 psi - welded models*
- UL/CUL file number: SA8547

Replacement Parts

PCN	Part	Contains
065847	Float Assembly Kit*	Flange w/intergral float ass'y and flange gasket
065849	Gasket Kit	Flange gasket

*Repairs AC & R series S1900 Standard and 5200 Helical Oil Separators

Standard Product Offering

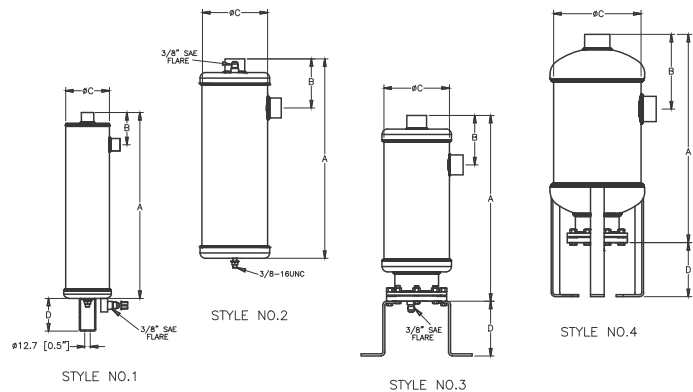

Capacity Table

Description	Solder Connection Size (ODF)	Syle Number	Shell O.D.	Maximum Capacity of Refrigeration at Evaporator Temperature												Oil Pre-Charge Amount (oz.)	Replaceable Float PCN				
				R-134a		R-22/407C		R-404A/507		R-410A											
				-40F	+40F	-40F	+40F	-40F	+40F	-40F	+40F										
A-WC 41777	7/8"	1	4"	4.5	16	5.6	19	7.1	25	8	28	6.3	22	8.3	29	11	38	12	43	14	N/A
A-WC 41999	1 1/8"			5.3	19	6.5	23	8.3	29	9.4	33	7.4	26	9.7	34	13	45	14	50		
A-WC 6181111	1 3/8"	2	6"	8.5	30	10	37	13	46	15	53	12	41	16	54	20	71	23	80	25	065847
A-WC 6181313	1 5/8"			12	42	15	51	19	65	21	74	16	58	22	76	28	100	32	112		
A-WC 6181717	2 1/8"			14	48	17	58	21	74	24	84	19	66	25	87	32	114	37	129		
A-FC 6221111	1 3/8"	3	6"	12	42	15	51	19	65	21	74	16	58	22	76	Not Available					
A-FC 6221111H	1 5/8"			14	48	17	58	21	74	24	84	19	66	25	87						
A-FC 6221313	1 5/8"	3	6"	14	48	17	58	21	74	24	84	19	66	25	87	Not Available					
A-FC 6221313H				14	48	17	58	21	74	24	84	19	66	25	87						
A-FC 6221717	2 1/8"	3	6"	14	50	17	61	22	77	25	88	20	69	26	91	Not Available					
A-FC 6221717H				14	50	17	61	22	77	25	88	20	69	26	91						
A-FC 8241717	2 1/8"	4	8"	23	80	28	97	35	124	40	140	31	110	41	145	Not Available					
A-FC 8241717H				23	80	28	97	35	124	40	140	31	110	41	145						
A-FC 10272121	2 5/8"	4	10"	45	159	56	195	71	248	80	280	63	220	83	290	Not Available					
A-FC 10272121H				45	159	56	195	71	248	80	280	63	220	83	290						
A-FC 12302525H	3 1/8"	4	12"	72	253	88	309	112	393	127	445	100	349	131	460	Not Available					
				72	253	88	309	112	393	127	445	100	349	131	460						

A-W & A-F Oil Separators

The A-W and A-F are used for multiple compressor racks in supermarkets and air conditioning systems for use with HCFCs, HFCs and their lubricants.

Features

- Hermetic welded or accessible bolted flange construction
- Solid copper connections
- Corrosion resistant epoxy powder paint



Nomenclature

example: AW 5582 4

A	W	5582	4
Series	W = Welded F = Flanged	Model Number	Connection Size (in 1/8")

Specifications

- Maximum working pressure: 450 psi
- UL/CUL file number: SA10468

Ordering Information* and Capacity Table

Description				R-12				R-22/R-407C				R-502				R-134a				R-404A/R-507			
FLANGED	PCN	SEALED	PCN	-40 F/C		40F (4C)		-40F/C		40F (4C)		-40F/C		40F (4C)		-40F/C		40F (4C)		-40F/C		40F (4C)	
				Tons	kW	Tons	kW	Tons	kW	Tons	kW	Tons	kW	Tons	kW	Tons	kW	Tons	kW	Tons	kW	Tons	kW
A-F 58824	060877	A-W 55824	060933	1	3.5	1.5	5.3	1.5	5.3	2	7.1	1.5	5.3	2	7.08	1	3.5	1.8	6.2	1.5	5.3	2	7.0
A-F 58855	060878	A-W 55855	060934	3	10.6	4	14.2	4.5	15.9	5.5	19.5	4.8	16.8	5.8	20.4	3.3	11.5	4.5	15.9	4	14.2	5.5	19.0
A-F 58877	060879	A-W 55877	060931	4.5	15.9	5.5	19.5	7	24.8	8	28.3	7.5	26.6	8.5	30.1	4.8	16.8	6.5	23	6.5	23	8.5	30.0
A-F 58889	060759	A-W 55889	060974	6	21.2	7.5	26.6	9	31.9	11	37.2	9.5	33.6	11.5	40.7	6.5	23	8.5	30.1	8.5	30.1	11	38.0
A-F 589011	060760	A-W 559011	060930	7.5	26.6	10	35.4	11.5	40.7	14	47.8	12	42.5	14.5	51.3	8	28.3	11.5	40.7	10.5	37.2	14	49.0
A-F 589213	060761	A-W 559213	060975	9	31.9	11.5	40.7	14	49.6	18	62	16	56.6	17.5	62	9.5	33.6	13.3	46.9	14	49.6	17	60.0
-	-	A-W 569011	060978	9	31.7	12	42.3	13	45.8	14	49.8	15	52.8	20	70.4	9.5	33.4	13.7	48.2	11	38.7	19	66.9
A-F 579213	060875	A-W 569213	060979	11	38.9	14	49.6	16	56.6	18	63.7	20	70.8	24	85	11.8	41.6	16	56.6	17.5	62	23	81
A-F 579417	060876	A-W 569417	060980	17	60.2	22	77.9	25	88.5	30	106	30	106	35	124	18	63.7	25.6	89.4	26	92.	34	121

*See replacement parts page. Repair kits for style 2 only.

Standard Product Offering

Dimensional Data

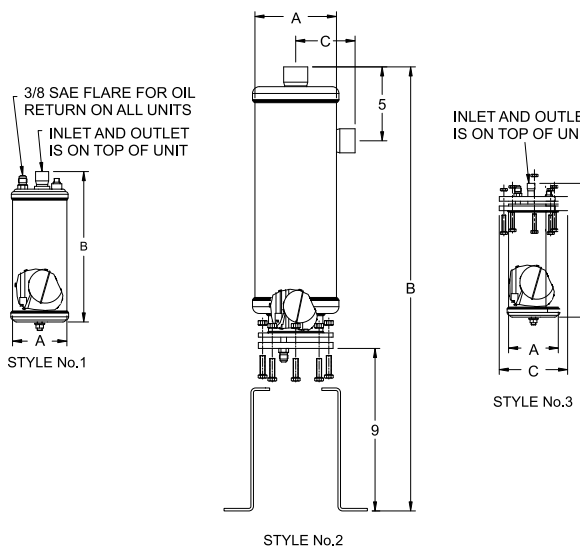

Seal Units: A-W

Description	Style No.	Connection Size	Dimensions (in)		Replaceable Float PCN	Oil Pre-charge Amount (oz)
			A	B		
A-W 55824	1	1/2 ODF	4.0	10.75	N/A	17
A-W 55855		5/8 ODF		13.2		
A-W 55877		7/8 ODF		15.0		
A-W 55889		1-1/8 ODF		16.25		
A-W 559011		1-3/8 ODF		19.5		
A-W 559213		1-5/8 ODF		19.88		
A-W 569011	2	1-3/8 ODF	6.0	15.75	N/A	20
A-W 569213		1-5/8 ODF		19.0		
A-W 569417		2-1/8 ODF		19.5		

Flanged Units: A-F

Description	Style No.	Connection Size	Dimensions (in)			Replaceable Float PCN	Oil Pre-charge Amount (oz)
			A	B	C		
A-F 58824	3	1/2 ODF	4.0	10.5	5.5	N/A	17
A-F 58855		5/8 ODF		15.0			
A-F 58877		7/8 ODF		18.0			
A-F 58889		1 1/8 ODF		21.25			
A-F 589011		1 3/8 ODF		21.37			
A-F 589213		1 5/8 ODF		21.75			
A-F 579213	2	1 5/8 ODF	6.0	20.12	4.37	065847	20
A-F 579417		2 1/8 ODF		20.31	4.63		

AOR Oil Reservoirs

The AOR oil reservoir is a holding vessel for stand-by oil necessary for the operation of commercial refrigeration systems. It is a direct replacement of popular competitive models.

Features

- Two sight glasses with floating ball indicators - 2 gallon model
- Three sight glasses with floating ball indicators - 4 gallon model
- 3/8" flare rotolock valves on top and bottom
- Corrosion resistant epoxy powder paint finish
- Standard mounting stud 3/8 x 16 TPI

Nomenclature example: AOR-3

AOR	3
Series	Gallons



Specifications

- Maximum working pressure: 450 psi
- UL/CUL file number: SA8547

Dimensional Data

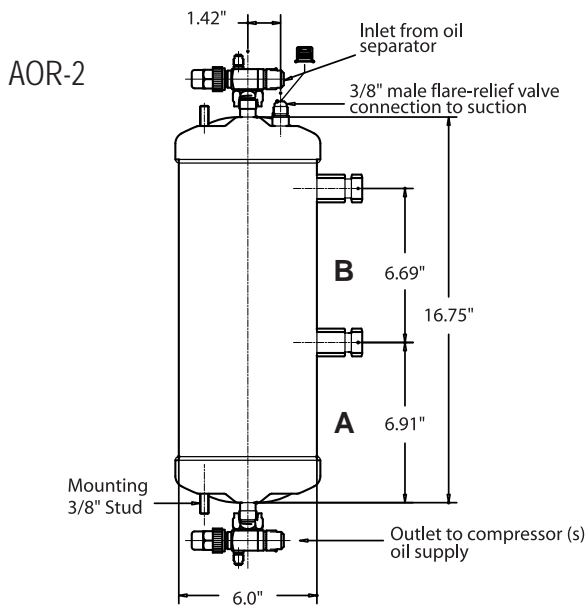

AOR-4

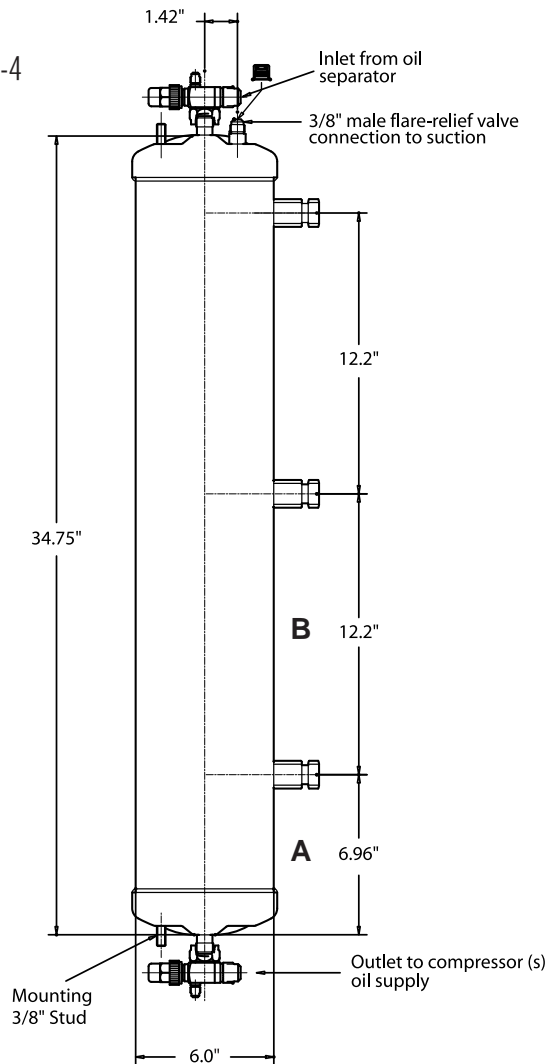

Ordering Information

PCN	Description	Total Volume Gallons	A Level Volume (gals)	B Level Volume (gals)	Length (in)	Number of sight glasses
064950	AOR-2	2	3/4	1-2/3	20"	2
065981	AOR-3	3	2/3	2-2/3	31"	3
064951	AOR-4	4	1-1/2	3-3/4	38"	

Replacement Parts for AOR Oil Reservoirs

PCN	Part	Contains
066002	Mounting Kit	Mounting brackets, self-tapping bolts and mounting stud nuts

Standard Product Offering

AOF High Efficiency Oil Filter

Highly Recommended for Scroll Compressors

The AOF is designed to protect the compressor from dirt and all solid contaminants including metallic magnetic particles. It is ideal for use with compressors that require a 4 micron or higher filtration rating.



R-410A

Features

- Corrosion resistant epoxy powder paint finish
- 3/8" SAE connections for easy installation in oil lines
- 100% efficient to 4 micron particles; 99% efficient to 3 micron particles
- Compatible with all oils
- High debris capacity with low pressure drop

Specifications

- Maximum working pressure: 680 psig
- UL/CUL file number: SA 3124

Ordering Information

PCN	Description	Lay-in	Diameter
064952	AOF 303	9.63	3.06

Standard Product Offering

AOF High Efficiency Take-Apart Oil Filter

The AOF is designed to protect the compressor from dirt and all solid contaminants including metallic magnetic particles. It is ideal for burnout/clean-up situations.



Features

- Compatible with all oils
- Solid copper connections
- Quick change filter cartridge
- Corrosion resistant epoxy powder paint finish
- 100% efficient to 4 micron particles; 99% efficient to 3 micron particles
- 3/8 ODF connections
- Quick removal cover design simplifies filter replacement
- High debris capacity with low pressure drop

Specifications

- Maximum working pressure: 450 psig
- UL/CUL file number: SA 7175

Ordering Information

PCN	Description
062784	AOF 023S*
064799	FO23 Cartridge

*Cartridge not included

Standard Product Offering

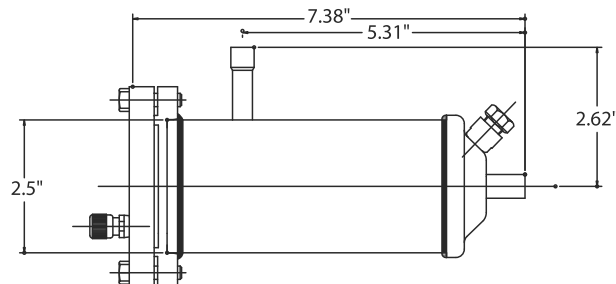

AOF 023S
Take-Apart OIL
FILTER



F 023
REPLACEABLE
FILTER CARTRIDGE

AOFD 553 Oil Filter Drier

The AOFD is designed specifically for refrigerant systems that use POE oil. POE oil is hygroscopic in nature, which means that it attracts and absorbs water. Moisture in a closed system can produce acid and will harm the compressor. The AOFD protects compressors by removing moisture and trapping contaminants.

Features

- Designed to clean and dry POE Oil
- 3/8" male flare connections for easy replacement
- 3 micron filtration for optimum oil cleaning
- Large filter surface area to provide maximum filtration
- Contains desiccant for moisture removal
- Designed to operate at a very low pressure drop
- Dual access valves for pressure drop monitoring

Dimensional Data

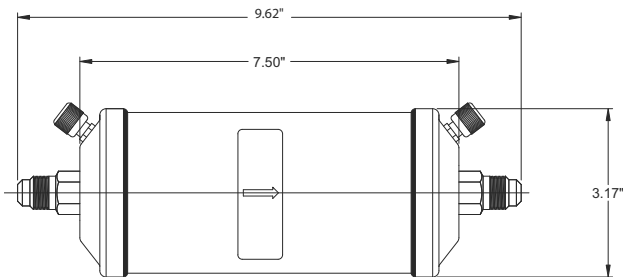

R-410A

Specifications

- UL/CUL file number: SA3124
- Maximum Working Pressure: 680 psig

AOFD Water Capacity Table

Refrigerant Type	Drops @ 125°F
R-22	497
R-134A	518
R-404A	518
R-407C / R-410A	435
R-744	563

Ordering Information

PCN	Description
062829	AOFD 553 Oil Filter Drier

Standard Product Offering

OMB

The OMB is a compressor crankcase oil level protective control ideal for use with Copeland Scroll® models ZF, ZB, ZR and ZS. It is also recommended for Copeland® brand products, Carlyle, Bitzer, and other semi-hermetic compressors.



R-410A

Features

- Precision oil level measurement for maximum protection
- Easy monitoring with alarm and status lights
- Foam resistant design prevents nuisance trips unlike optical sensor designs
- Contaminant proof operation ensures accurate control
- Only approved oil level control for Copeland Scroll® Compressors
- 5-time lockout feature protects compressor from repeated low oil level condition
- Self-contained unit with oil level sensor and integral solenoid to manage oil level supply
- Reverse Hall-effect sensor for precise measurement of oil level and protection from sensor magnetic debris contamination
- SPDT output contact for compressor shut-down and alarming
- Easy installation by sightglass replacement
- Adapters suitable for various types of scroll compressors (not required for reciprocating compressors)
- UL Recognized (File Number # MP604)
- Fluorescent floating ball
- Integral sight glass

Specifications

- Maximum working pressure: 640 psi
- Solenoid MOPD: 350 psi
- Supply voltage: 24 V AC, 50/60 Hz
- Solenoid coil: ASC 2L 24 V AC, 50/60 Hz
- Current consumption: 0.6A
- Time delay for low level signalling: 5-10 seconds
- Time delay for after setpoint recovery: 5-10 seconds
- Alarm delay time: 120 seconds
- Alarm switch: SPDT
- Alarm contact rating: 10A @ 125; 5A @ 220 V AC
- Refrigerant compatibility: HFC, HCFC, CFC
- Oil temperature: 180°F Max.
- Storage and transport temperature: 140°F Max.
- Operating ambient temperature: 120°F Max.
- Oil supply fitting: 1/4" Male SAE
- UL/CUL file number: SA8547
- Transformer VA requirements* 25"

*NOTE: Field supplied transformer should always be of the same primary voltage as the electrical supply system.

Nomenclature example: OMB-JB1 ASC2 24 50/60

OMB	JB1	ASC2 24 50/60
Oil Management Control	JB1 - Junction Box MO1 - Series Relief Connector	Solenoid Coil Model Number, Voltage, Frequency (included)

Ordering Information

PCN	DESCRIPTION
	Oil Management Control
065365	OMB-JB1 ASC 2 24/50-60 - STD
065366	OMB-MO1 ASC 2 24/50-60 - STD
	Adapters (to attach OMB to Copeland Scroll® compressor for new installation only)
065668	OMB-ACA ADAPTER (3/4" x 14 NPTF) Copeland® Glacier, ZF, ZS, ZB
065667	OMB-ACB ADAPTER (1 1/8" x 12 UNF) Copeland® A/C ZR
066077	OMB-ACD ADAPTER (1 1/4" x 12 UNF) Copeland® A/C Summit Series
066078	OMB-ACE ADAPTER (1 3/4" x 12 UNF) Copeland® Specter Series
063521	OMB-AVA for Copeland® 6D Semi-Hermetic
065982	OMB-ASA Carlyle Compressors DA, DR, 5F, 5H, 06D and 06E
	Service Parts
048638	Inlet Flare Screen
020877	Sight Glass O-Ring
064812	Mounting O-Rings (3 pieces)
049191	KS-30112 Solenoid Repair Kit

Standard Product Offering

Dimensional Data

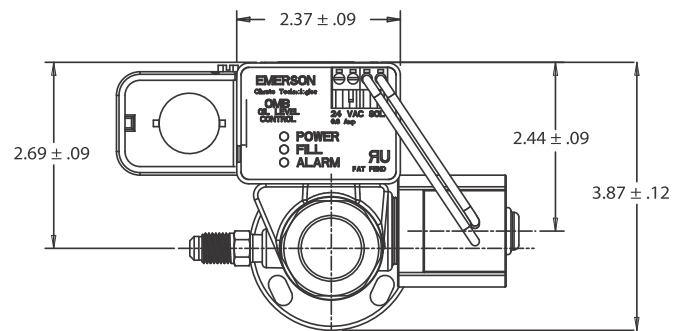

Unit must be mounted horizontally for correct operation.

W-OLC Mechanical Oil Level Regulator

The W-OLC controls the oil level in the compressor crankcase with a float operated valve and keeps the oil level at the compressor manufacturer's recommended level. It is a direct replacement of popular competitive models.

Features

- Corrosion resistant epoxy powder paint finish
- Universal mounting pattern for standard semi-hermetic compressors

Nomenclature example: W-OLC-2

W-OLC	2
Series	Sight Glass*

* 2 = 1/2, 4 = 1/4, 2-4 = adjustable

Dimensional Data

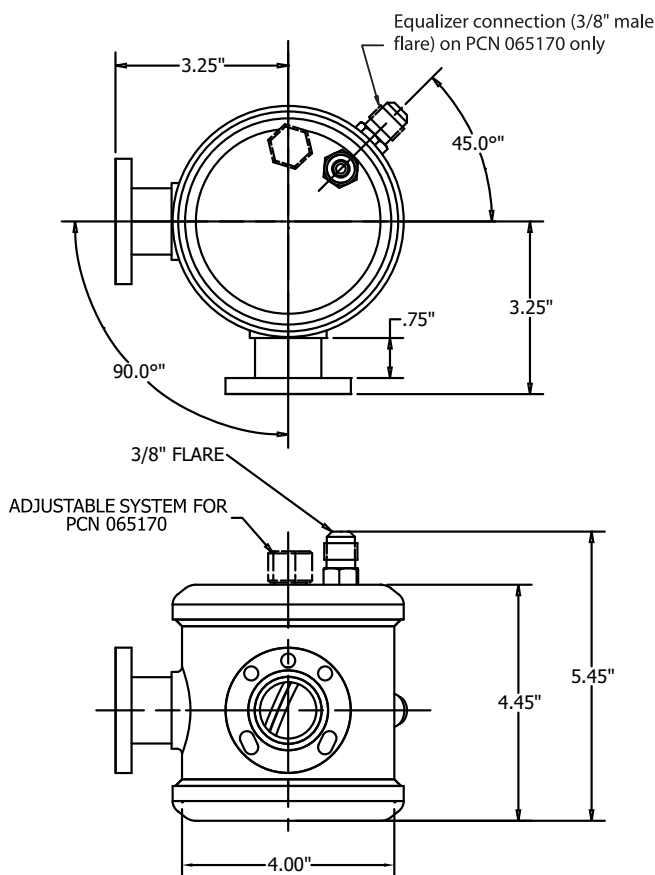

See adapters page.



Specifications

- Maximum working pressure: 450 psi
- UL/CUL file number: SA8547
- Max. OPD: 90 psi

Ordering Information

PCN	Description	Sight Glass Level
064953	W-OLC-2	1/2 sight glass
064954	W-OLC-4	1/4 sight glass
065170	W-OLC-2-4	1/4 to 1/2 level (adjustable)

Standard Product Offering

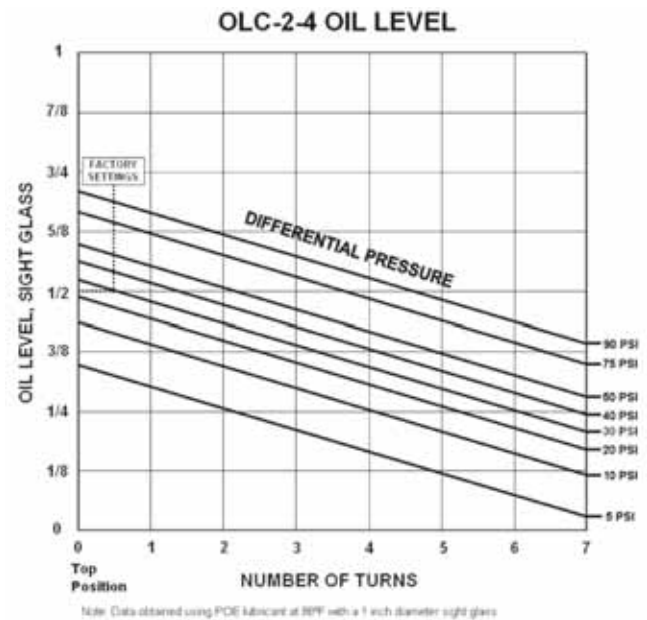

The Oil Level factory setting is in the middle of the Sight Glass at 30 PSI for the Oil Level Control. Located on the top of the control is the seal cap. Remove this to adjust the oil level. To adjust the stem, turn it clockwise and counterclockwise, respectively, to lower and raise the stem. One can determine the adjustment needed from the OLC-2-4 Oil Level Chart. One eighth of an inch increments are used to illustrate the oil level at a selection of differential pressure conditions.

Unlike our Competitors Controls no damage will occur when attempting to adjust beyond 7 turns. Our Design has a hard Stop to prevent damage.

In the case of an unexpected system defrost or load increase, large amounts of oil will return through the suction line. Consequently, the oil control will not be able to keep the oil level from rising beyond the control point.

Universal Acid Test Kit

The Universal Acid Alert Test Kit provides a reliable indication as to the acid level of the refrigeration oil.

Features

- Quick and easy test kit
- Universal acid test kit for use with all refrigeration lubricants
- By changing the percentage of oil sample taken, the acid number of the oil can be accurately determined
- Phase separation of the chemicals eliminates interference from discolored oil



Ordering Information

PCN	Description
064427	AA Kit Universal

Standard Product Offering

Thermal
Expansion Valves

TXV Extended
Capacity Tables

EX Valves
and Controls

Solenoid Valves
and Coils

Solenoid Capacity
Tables

Industrial Solenoid
Valves

Shut Off
Valves

System
Protectors

System Protectors
Capacity Tables

Oil
Controls

Temperature
Pressure Controls

Quick Select Guide

Application	Feature	Type
Commercial Refrigeration Air Conditioning Controls	Temperature Control, Adjustable Set Point and Differential	TS1
	Single Pressure Control, Adjustable Set Point and Differential	PS1
	Dual Pressure Control, Adjustable Set Point and Differential	PS2
	Differential PressureControl	FD113
Mini-Pressure Controls	Mini-Pressure Control	PSC
	Electronic Fan Speed Control	FSX
Industrial Pressure Controls	Industrial Pressure Control, U.L. Approved	FF444

Thermal Expansion Valves

TXV Extended Capacity Tables

EX Valves and Controls

Solenoid Valves and Coils

Solenoid Capacity Tables

Industrial Solenoid Valves

Shut Off Valves

System Protectors

System Protectors Capacity Tables

Oil Controls

Temperature Pressure Controls

TS1 Series Single Control

The TS1 series adjustable thermostats are designed for application in refrigeration and heat pump systems. In these systems, thermostats serve control and monitoring functions, such as space temperature control, high/low temperature alarming or defrost termination. By operating a set of electrical contacts, a temperature value is kept inside a certain limit.



Features

- Adjustable temperature and differentials
- Range and differential individually lockable by wire seal
- Captive terminal and cover screws
- Manual toggle for system checkout and override
- Bellows heater for thermostats with vapour charge
- Standard accessories include mounting brackets and knob with lockplate on all individually packed controls
- Non-ambient sensitive
- Heavy-duty SPDT switch allows handling of most loads directly without the use of relays

Specifications

- Ambient temperature ranges -50°C to +70°C (-58°F to +158°F)
- SPDT switch rated for 120 VAC/240VAC at 24FLA and 144 LRA
- Agency approvals include: UL/CUL file number E85974, VDE 0631/0660, TÜV, CE 73/23/EWG, CE 93/68/EWG

Options

- Vapor charges
- Factory set to customer specification
- Different types of mounting brackets
- Sensor bulb wells and capillary tube holders
- Special approvals
- Range and differential pointer in units °C and °F

Nomenclature example: TS1 B1E

TS1	B	1	E
Product Name	Housing Variant/function	Temperature Range	Sensor Type
TS1 = Adjustable thermostat TSA = Customer specials	C = Frost monitor, auto reset D = Frost monitor, manual reset	0 = +40 to +68°F (+4.5 to +20°C) NOTES Temp ranges 0-4: manual reset for falling temperature	P = Vapor Charge, 6m. capillary

Thermal Expansion Valves
TXV Extended Capacity Tables
EX Valves and Controls
Solenoid Valves and Coils
Solenoid Capacity Tables
Industrial Solenoid Valves
Shut Off Valves
System Protectors
System Protectors Capacity Tables
Oil Controls
Temperature Pressure Controls

PS1 Series Single Control

PS1 Single Pressure Controls are designed for use on high and low pressure applications in refrigeration and heat pump systems. By operating a set of electrical contacts, pressure is kept inside a certain limit.

Features

- Adjustable pressures and differentials
- Narrow adjustable differential depending on model
- Range and differential pointer in units bar and psig
- Range and differential individually lockable by wire seal
- High rated SPDT contacts for all versions
- Captive terminal and cover screws
- Manual toggle for system checkout and override
- Factory installed wire bridge for reduced installation effort



Options

- Different pressure connections
- Automatic and manual reset versions
- Factory set to customer specification
- Different types of mounting brackets

Specifications

- SPDT switch rated for 120 VAC/240VAC at 24FLA and 144 LRA
- Agency approvals include: UL/CUL file number E85974, VDE 0631/0660, TÜV, CE 73/23/EWG, CE 93/68/EWG
- Low and high pressure versions available with TÜV approval according to EN 12263 (supercedes DIN 32733) to meet requirements of DIN 8901 and EN378 (supercedes DIN 8975)

Nomenclature example: PS1-A5K

PS1	A	5	K
Product Name	Housing Variant/function	Pressure Range	Sensor Type
PS1 = Adjustable single Pressure Control	X = Pressure control, automatic reset, external range and differential adjustments Y = Pressure control, external manual reset, external range, and differential adjustments	3 = 15" Hg to 100 psig (-0.5 to 7 bar) 4 = 15 to 290 psig (1 to 20 bar) 5 = 90 to 450 psig (6 to 31 bar)	A = 7/16" - 20 UNF male for 1/4" SAE male flare K* = 7/16" - 20 UNF flare nut with 1 meter (3 ft.) cap tube
PSA = Customer specials			*Controls with housing variant X have extended copper ends, without Schrader valve depressor. All other housing variants have Schrader valve depressor and brass end fitting with copper gasket.

Thermal Expansion Valves
TXV Extended Capacity Tables
EX Valves and Controls
Solenoid Valves and Coils
Solenoid Capacity Tables
Industrial Solenoid Valves
Shut Off Valves
System Protectors
System Protectors Capacity Tables
Oil Controls
Temperature Pressure Controls

PS1 Series Single Control

Ordering Information

Single Pressure Control	PCN	Adjustment Range		Factory Setting (psig)	Pressure Connection
		Upper Setpoint (psig)	Differential Setpoint (psig)		
Low Pressure Controls					
PS1-X1A	097894	24" Hg to 42 psig	4 to 29	7/15	Capillary Nut
PS1-X3A	097914	15" Hg to 100 psig	7 to 73	50/65	7/16" -20 UNF, 1/4" SAE male
PS1-X3K	097904				Capillary Nut
High Pressure Controls					
PS1-X5K	097908	90 to 450 psig	29 to 217	230/290	Capillary Nut
PS1-V5K	097911		Ext. Manual Reset	290	7/16" -20 UNF, 1/4" SAE male Capillary Nut

Standard Product Offering

Dimensional Diagram (in)

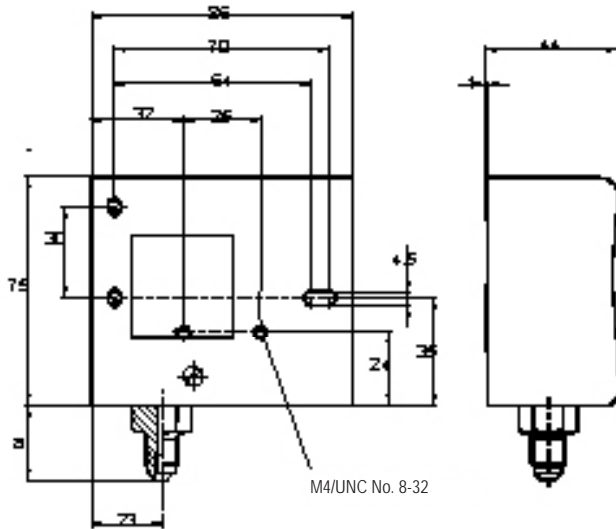

PS2 Series Dual Control

PS2 Dual Pressure Controls are designed for use on high and low pressure applications in refrigeration and heat pump systems. By operating a set of electrical contacts, pressure is kept inside certain limits.

Features

- Adjustable pressures and differentials
- Narrow adjustable differential depending on model
- Range and differential pointer in units bar and psig
- Range and differential individually lockable by wire seal
- High rated SPDT contacts for all versions
- Captive terminal and cover screws
- Manual toggle for system checkout and override
- Factory installed wire bridge for reduced installation effort



Options

- Different pressure connections
- Automatic and manual reset versions
- Factory set to customer specification
- Different types of mounting brackets

Specifications

- SPDT switch rated for 120 VAC/240VAC at 24FLA and 144 LRA
- Agency approvals include: UL/CUL file number E85974, VDE 0631/0660, TÜV, CE 73/23/EWG, CE 93/68/EWG
- Low and high pressure versions available with TUV approval according to DIN 32733 to meet requirements of DIN 8901 and DIN 8975

Nomenclature example: PS2-Y7A

PS2	Y	7	A
Product Name	Function	Pressure Ranges	Pressure Connector Type
PS2 = Adjustable Dual Pressostat PSB = Customer special Version	A = <u>Both sides</u> : Pressure controls, Automatic reset, Internal range and differential adjustments. L = <u>Left side</u> : Pressure control, Automatic reset, Internal range and differential adjustments. <u>Right side</u> : Pressure cut out, External manual reset, Internal range and differential adjustments. X = <u>Both sides</u> : Pressure controls, Automatic reset, External range and differential adjustments. Y = <u>Left side</u> : Pressure control, Automatic reset, External range and differential reset, External range and differential adjustments. LOW PRESSURE MANUAL RESET: Cut outs with manual reset function and in combination with the low pressure side of Pressure Ranges 7 & 9 have a low pressure manual reset function (15 psig differential). HIGH PRESSURE MANUAL RESET: Cut outs with manual reset function and in combination with the high pressure side of Pressure Ranges 7 & 9 have a high pressure manual reset function (60 psig differential).	7 = Left side: 15" Hg to 100 psig (-0.5 to 7 bar) Right side: 90 to 450 psig (6 to 31 bar)	A = 7/16" -20 UNF male for 1/4" SAE flare fitting K* = 7/16" -20 UNF flare nut with 1 meter (3 ft.) cap tube L = 1/4" ODM solder with 1 meter (3 ft.) cap tube * Controls with housing variants X/Y have extended copper ends, without Schrader valve depressor. All other housing variants have Schrader valve depressors and brass end fitting with copper gasket.

Ordering Information

Dual Pressure Control	PCN	Adjustment Range				Factory Setting PSIG		Pressure Connection
		Upper Setpoint		Different Setpoint		Left psig	Right (psig)	
		Left psig	Right (psig)	Left psig	Right (psig)			
Continued Pressure Limiter/Pressure Cut Out for Low Pressure/High Pressure Protection								
PS2-Y7A	097954	15" Hg to 100	90 to 450	7 to 72	Convertible Auto/Manual Reset	50/65	290	7/16" -20 UNF
PS2-Y7K	097943							Capillary Nut

Standard Product Offering

FD113-ZUK Oil Pressure Safety

The FD113 Oil Pressure Safety Control senses the effective oil pressure on pressure lubricate compressors. If inadequate oil pressure exists, a time delay is energized. If the oil pressure does not recover to safe levels within the time delay setting, the compressor is shut down. The time delay allows the compressor adequate time to establish oil pressure on start up and avoids nuisance shutdowns on pressure drop of short duration during the run cycle.

Maximum application flexibility is assured by providing an adjustable differential pressure switch which can be adjusted to the compressor's minimum required oil pressure needs and an adjustable electronic time delay which allows the selection of the length of time the compressor runs below the minimum pressure before shutdown. The minimum pressure setting and time delay values specified by the compressor manufacturer should be used when installing the FD113 control.

Features

- Pressure range adjustable from 4 to 65 psid; Timer start pressure - timer stop pressure is 3 psid above timer start pressure
- A SPDT switch is used in the pressure portion of the control which allows the addition of a "safe-light" when desired
- Electronic Timer is Time-Adjustable from 20 to 150 seconds
- Supply voltage - 24 to 240 Volt AC/DC; Timing unaffected by voltage or ambient temperature variations
- A SPDT Manual Reset Switch is used in the Timer Module; Upon time-out, the compressor is stopped and an alarm circuit is energized; To restart the compressor and deenergize the alarm circuit, the reset button is pushed
- A factory installed Jumper allows the FD113 to be powered from a single source power; Should separate circuits be desired for the timer and "Lockout" switch, the Jumper can be removed

Specifications

- Agency approvals include: UL/CUL file number E85974, VDE 0631/0660, TÜV, CE 73/23/EWG, CE 93/68/EWG

Ordering Information

PCN	Part Number	Adjustable Pressure Range	Adjustable Time Delay	Supply Voltage	Pressure Connection
097456	FD113-ZUK	4-65 psid	20 to 150 seconds Factory-set at 120 seconds	24 to 240V AC/DC	(2) 3/8" capillary with 1/4" flare nut

Standard Product Offering



Dimensional Data (in)

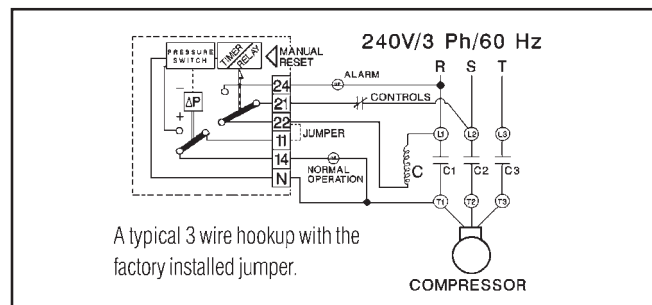
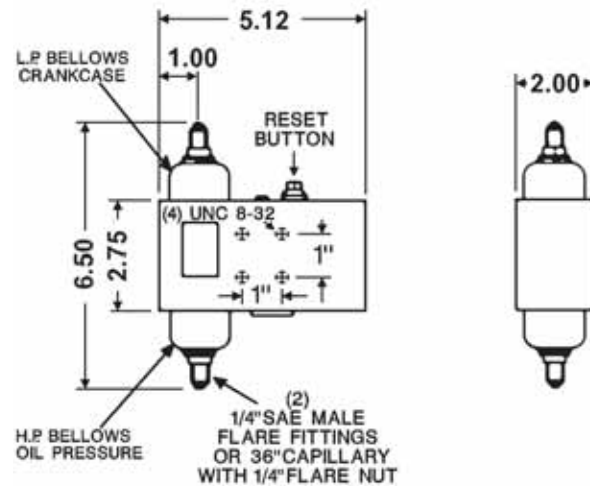

PSC Mini Pressure Control

The PSC Mini Pressure Control provides the ultimate in reliability and flexibility in a commercial grade mini pressure control. A standard plug connectable design simplifies installation and service. The SPDT switch allows the addition of alarm circuits on high or low pressure applications. Models with high temperature bellows and built-in pressure pulsation snubbers make the PSC ideally suited for compressor head mounting high pressure limit control applications—automatic or manual reset versions are available.

Pressure Ranges/Differential also make the PSC controls ideally suited for condenser fan cycling applications. Low Pressure versions with standard or narrow differential switches make these controls ideally suited low pressure limit or back-up safety controls on electronically controlled systems. Numerous options, such as panel mount or capillary connections are available on high volume applications. Standard on all models are worldwide agency approvals.

Typical Applications

- High Pressure Limit/Alarm
- Condenser Fan Cycling
- Low Pressure Limit/Alarm
- Low Pressure Cycling (Back-Up)
- Defrost Termination/Fan Delay
- Rupture Guard Alarm

Features

- Commercial Grade High/Low/Condenser Fan Cycling Pressure Controls for use on Refrigeration/AC Applications
- Mini-Size 2" x 1-1/2" x 2-3/4"
- Standard SPDT Switch Action
- Automatic or Manual Reset
- Models available with high temperature bellows and built-in pressure pulsation snubber for direct head mount high pressure sensing/limit applications
- Plug Connectable with hub for 1/2" flexible conduit
- Factory preset to customer's desired pressure specifications
- Precise, repeatable settings
- Narrow differential "Micro" switch available on low pressure models



R-410A

Specifications

- Worldwide Approvals: UL/CUL/VDE/TÜV
- UL/CUL file number: E85974

Electrical Ratings—SPDT Switch

- Standard Switch – High/Low Pressure
 - Load Contact: 6 FLA – 36 LRA – 120/240 VAC
 - Pilot Duty: 240VA @ 120, 480VA @ 240 VAC
 - Back Contact 0.5 Amp 120/240 VAC Pilot Duty
- Micro Switch – Low Pressure
 - 2.5 FLA – 15 LRA – 120/240 VAC
 - Pilot Duty: 120VA @ 120, 240VA @ 240 VAC
 - Back Contact 0.5 Amp 120/240 VAC Pilot Duty

Ambient Temperature

- Storage: -30° to +160°F Operating: -20° to +140°F
- Low Pressure
 - Single diaphragm
 - Maximum media temperature 150°F
- High Pressure
 - Bellows design
 - Maximum media temperature 300°F
 - Internal Pressure Pulsation Snubber available for direct head mount

Protection

- Protect from rain, direct sunlight and exterior damage

Weight

- Approximately 0.25 pound, depending upon configuration

Compatibility

- HFC, HCFC, CFC

Agency Approvals

- UL/CUL/DIN/TÜV, depending upon configuration

Switch Action

- SPDT Standard
 - 1-2 Open on Rise
Close on Fall
 - 1-4 Close on Rise
Open on Fall

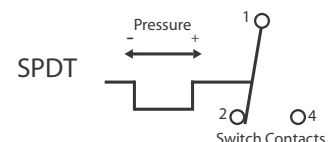

Thermal Expansion Valves
TXV Extended Capacity Tables
EX Valves and Controls
Solenoid Valves and Coils
Solenoid Capacity Tables
Industrial Solenoid Valves
Shut Off Valves
System Protectors
System Protectors Capacity Tables
Oil Controls
Temperature Pressure Controls

PSC Mini Pressure Control

Nomenclature example: PSC-W6S

PSC	W	6	S
Product Name	Function	Pressure Range/Contacts	Pressure Connections
	<p>A = Pressure control, automatic, high or low pressure applications (Single diaphragm option, 158° F rating, Range 1-5 only, without snubber) (Bellows option, 300° F rating, with snubber, Range 6 only)</p> <p>B = Pressure cut-out, external manual reset, DIN/TUV approved (Double diaphragm option, 158° F, without snubber, Range 1-5) (Bellows option, 300° F rating, with snubber, Range 6 only)</p> <p>R = Pressure control, external manual reset, high or low pressure applications (Single diaphragm option, 158° F rating, Range 1-5 only, without snubber) (Bellows option, 300° F rating, with snubber, Range 6 only)</p> <p>W = Pressure limiter, automatic, DIN/TUV approved (Double diaphragm option, 158° F, without snubber, Range 1-5) (Bellows option, 300° F rating, with snubber, Range 6 only)</p>	<p>Standard Contacts</p> <p>1 = Low pressure 15" Hg to 90 psig 5 = High pressure 100 to 465 psig 6 = High pressure 145 to 623 psig</p> <p>Microswitch Contacts</p> <p>J = Low pressure 15" Hg to 90 psig</p>	<p>K = 1 m cap tube w/flare nut 7/16"-20 UNF (range 1-5)</p> <p>L = 1/4" ODM solder w/1 m cap tube (range 1-5)</p> <p>S = 7/16"-20 UNF female, Schrader depressor (range 1-6)</p>

Specification Selection Table

PCN	Type and Description	High Event Range (PSIG)	Differential Range (PSID)	Setting	Reset Function	Pressure Connection	Electrical Connection	Electrical Ratings	Maximum Over Pressure	Mounting
Low Pressure Controls										
097815	PSC-AJS ¹	15" to 90	4 Low / 7 High	1.5/6	Auto	1/4" SAE Female with Valve Depressor	DIN Plug with 1/2" NPTF Hub for Flex Conduit Connection 36" Cable	2.5 FLA/15 LRA	360 PSIG	Free Standing Direct Mount
097849	PSC-A1S		9 Low / 15 High	5/15				6 FLA/36 LRA		
High Pressure Controls										
097793	PSC-W6S	145 to 623	72 Low / 87 High	320/395	Auto	Same as above, plus stainless steel bellows with snubber	DIN Plug with 1/2" NPTF Hub for Flex Conduit Connection 36" Cable	6 FLA/36 LRA	695 PSIG	Free Standing Direct Mount
097998	PSC-B6S			395	Manual					

¹ Micro-Switch Construction.

² All switches SPDT ratings stated are 1 side only 120/240 VAC. Opposite switch side - 1/2 amp pilot duty 120/240.

Standard Product Offering

PSC Setting Capabilities

The PSC is factory preset.

For special applications, these controls can be factory preset to other values as illustrated on the appropriate graphs.

Standard Switch Setting Capability Pressure Range = 6

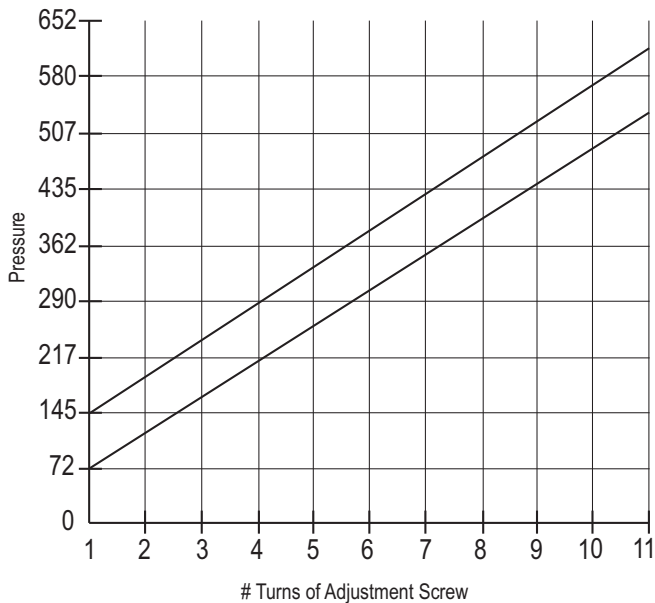

Micro-Switch Setting Capability Pressure Range = J

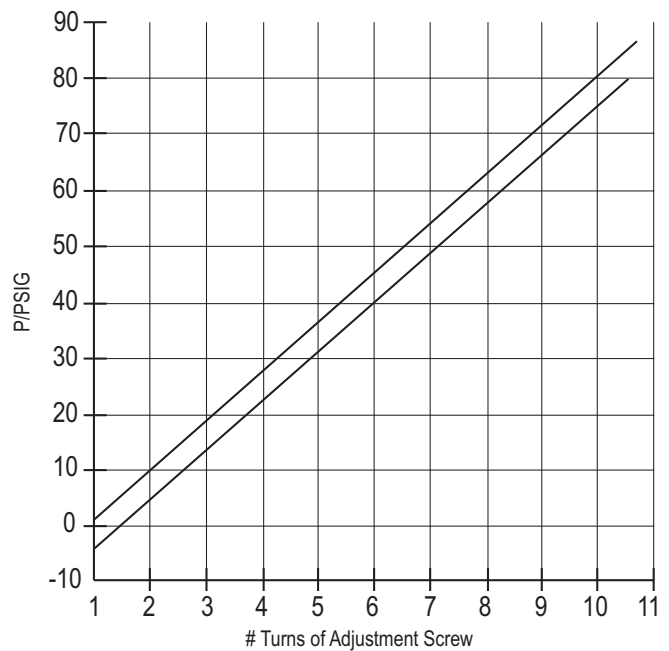

Standard-Switch Setting Capability Pressure Range = 1

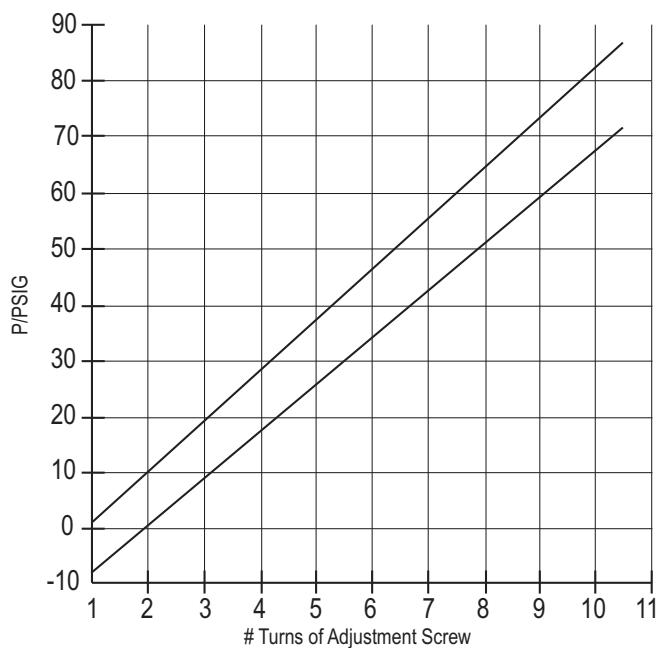

Standard-Switch Setting Capability Pressure Range = 5

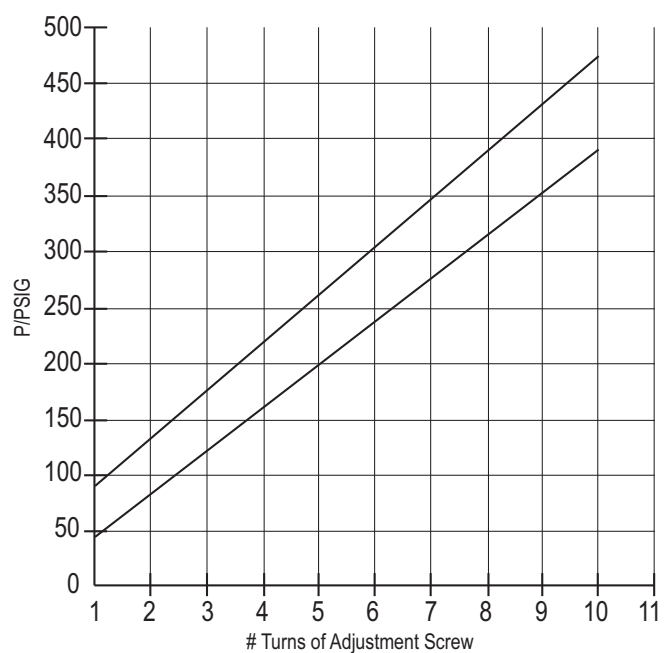

Thermal Expansion Valves
TXV Extended Capacity Tables
EX Valves and Controls
Solenoid Valves and Coils
Solenoid Capacity Tables
Industrial Solenoid Valves
Shut Off Valves
System Protectors
System Protectors Capacity Tables
Oil Controls
Temperature Pressure Controls

FSX Electric Fan Speed Control

The FSX Fan Speed Control controls the head pressure in air-cooled condensers by reducing the fan speed to maintain head pressure as the outside temperatures/condenser pressure drops. As the motor speed drops under lower ambient/load condition fan noise is also reduced.

The FSX is designed for use with permanent split capacitor and shaded pole fan motors, approved for use by motor/equipment manufacturers for variable voltage, phase angle (triac) speed control.

Features

- Connector includes 2 m. cable installed (FSF and FSO)
- Connector turnable (in 90° steps)
- Compact Design
- State-of-the-Art Electronics
- Direct mount—Easily retrofit to suitable motor
- Low Pressure “Turn Off” Operation
- Adjustable Pressure Setting
- Multiple FSX controls can be used in parallel on multi-circuit condensers
- 2 Cable types:
FSF-N15 with internal circuit design to comply with EC-Directive 89/336/EC (Electromagnetic compatibility requirements for Europe)
FSO-N15, standard with internal voltage spike and over current protection

Options

- Custom Calibration
- Other Operating Voltages/Pressure Ranges

Nomenclature example: FSX-41S

FS	X	4	1			S
Fan Speed Control	Series	Max. Current Rating 4 = 4 Amps maximum at 104°F ambient temperature	Pressure Range			Pressure Connection S = 1/4" SAE female (7/16" -20 UNF) with Schrader Depressor
			Pressure Range	Modulating Band	Factory Setting	
			1 = 6.5 to 15 bar (95 to 220psig)	35 psig	11 bar (160 psig)	
			2 = 13 to 25 bar (190 to 360 psig)	55 psig	16.2 bar (235 psig)	
		3 = 12.4 to 28.4 (180 to 411 psig)	66 psig	21.8 bar (316 psig)		

Ordering Information

Description	PCN	Adjustable Range	Modulating Band	Factory Setting	Pressure Connection
			(PSI)		
FSX-42S	097993	190 to 360	55	235	7/16" -20 UNF Female
FSX-43S	097774	180 to 411	66	316	

Standard Product Offering

Parts/Accessories

PCN	TYPE
097995	FSF-N15 Cable (EMC)
097775	FSO-N15 Cable (standard)

Standard Product Offering



R-410A

Specifications

- Nominal current: 0.2 to 4 Amp max up to 104°F (40°C)
0.2 to 2.5 Amp max up to 140°F (60°C)
max. 8 Amp
- Starting current: max. 8 Amp
- Temperature Range
 - Storage and transportation: -30°C to 70°C
 - Ambient temperature: -20°C to 55°C
 - Medium temperature: -20°C to 70°C
- Pressure Operated Fan Speed Control
- Supply Voltage: 230V AC + 15-20%.
- Protection: Provide an ultimate enclosure to protect from direct rain, sunlight and external damage.
- Weight: 3-1/2 ounces
- Approvals: UL/CUL file number E183816
CE Low Voltage Directive 72/23/EC
Connector per DIN 43650

FF444 Industrial Pressure Control

The FF444 Industrial Pressure Controls are general purpose switches suitable for oil, water and air at pressures up to 465 psig.

Typical Applications

- Industrial Pressure Control
- Pneumatic and Hydraulic Systems
- Oil Lubrication Systems
- Pump/Compressor Control

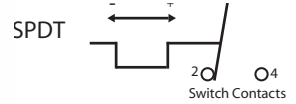

Features

- SPDT snap-action contacts
- Independent adjustable upper and lower switching pressures
- Diaphragm-type control for low pressure applications (Buna N diaphragm):
 - resistant to mineral oils
 - medium temperatures up to 160°F
- Transparent polyamide hood – U.V. resistant
- Surface mounted Type 4 enclosure
- Optional manual reset locking on pressure rise

Specifications

- Control circuit rating: 5 A (B300)
- Rated voltage: 300 VAC maximum
- Ambient operating temperature: -10°F to +120°F
- Medium temp. at pressure element: + 160°FMax.
- Resistance to vibration: (4 Hz to 1000 Hz) 4g
- Weight: 1.1 lbs.
- UL/CUL file number: E85974

Options

- Optional manual reset locking on pressure rise

Description	120VAC	240VAC
Maximum motor rating single phase	1/2 hp	1 - 1/2 hp
Motor rated, FLA	10 A	10 A
Motor rated, LRA	60 A	60 A

Nomenclature example: FF444-V2-DRF

FF444	V2					D	R	F
Industrial Pressure Control		Lower Switch Point Range	Upper Switch Point Range	Smallest Differential @ Lower-Higher end of Range	Standard Settings	Valve Design D = Diaphragm	Reset Type A = Auto R = Manual, Locking on Pressure Rise	Pressure Connection A = 7/16"-20 UNF male F = 1/4"-18 NPTF
	V4	6-217 psig 0.4-15 bar	15-232 psig 1-16 bar	9-14 psig 0.6-1 bar	58/174 psig 4/12 bar			
	V5	12-435 psig 0.8-30 bar	29-464 psig 2-32 bar	17-29 psig 1.2-2 bar	145/290 psig 10/20 bar			

Dimensional Data (in)

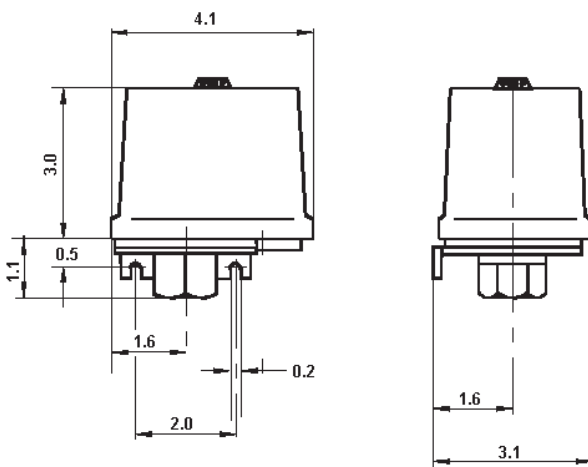

Ordering Information

PCN	Description
097311	FF444-V4-DAF
097312	FF444-V5-DAF
097379	FF444-V4-DRF

Standard Product Offering